

CITY OF ELYRIA, OHIO

PROJECT SPECIFICATIONS

FOR

**Lead Service Line Replacements Project  
Phase 4, 2024**

**WSRLA Funded Project**

Chris Pyanowski  
Safety-Service Director

241558

**TABLE OF CONTENTS**

Invitation to Bid.....	5-6
Instructions to Bidders.....	7-16
Agreement Form.....	17-21
Notice to Commence Work Form.....	22
Finance Director's Certification of Funds Form.....	23
MBE/WBE Form 1A – 6100-3 Proposed MBE/WBE Subcontractor*	CF.EPA.4 – CF.EPA.5
* To be signed by Bidder & Proposed Subcontractor – attach MBE/WBE Certificate	
MBE/WBE Form 1B – 6100-4 MBE/WBE Subcontractor List**	CF.EPA.6 – CF.EPA.7
** Summary of All Subcontractors to be signed by Bidder	
Build America, Buy America (BABA) Acknowledgement	CF.EPA.8
American Iron & Steel Acknowledgement	CF.EPA 9
<b>Bid Forms</b>	
Resolution of Directors.....	24
Bid Form .....	25-32
Bid Guaranty and Contract Bond.....	33
Consent of Surety Form.....	34
Bidder's Insurance Agent's Affidavit Form.....	35
Bidder's Insurance Certificate.....	36
Tax Affidavit Form.....	37
Bidder's Affidavit.....	38
EEO Certification.....	BF.EPA.1
Debarment Form 5700-49.....	BF.EPA.2
MBE/WBE Data Sheet I.....	BF.EPA.3
Supplementary Conditions.....	39-40
Equal Employment Opportunity Clause.....	41-42
Contractor's/Vendor's Affirmative Action Information Sheet.....	43-44
Prices to Include .....	BD.1 – BD.6
Project Specific Requirements .....	PSR.1 – PSR.2
Standard Specifications.....	SS.1

LEAD SERVICE LINE REPLACEMENTS

Technical Specifications

**DIVISION 1 - GENERAL REQUIREMENTS**

011100	SUMMARY OF WORK
011419	USE OF SITE
011423	ADDITIONAL WORK, OVERTIME
012513	PRODUCT SUBSTITUTION PROCEDURES
013119	PROJECT MEETINGS
013216	CONSTRUCTION PROGRESS SCHEDULE
013236	VIDEO MONITORING AND DOCUMENTATION
013319.01	FIELD TEST REPORTING – AGGREGATE, SOILS, CONCRETE AND ASPHALT
013323	SHOP DRAWINGS, PRODUCT DATA AND SAMPLES
013326	PRODUCT TESTING AND CERTIFYING
013543	ENVIRONMENTAL PROTECTION
014126	GENERAL REGULATIONS AND PERMITS
014223	INDUSTRY STANDARDS
014323	QUALIFICATIONS OF TRADESMEN
015100	TEMPORARY POWER SERVICE
015136	TEMPORARY WATER AND DISTRIBUTION
015526	TEMPORARY TRAFFIC CONTROL DEVICES
015800	PROJECT IDENTIFICATION
016600	PRODUCT HANDLING AND PROTECTION
017800	FINAL COMPLIANCE AND SUBMITTALS
017821	CLEANING AND PROTECTION
017839	PROJECT RECORDS, DRAWINGS

**DIVISION 2 - EXISTING CONDITIONS**

024119	REMOVAL OF STRUCTURES AND OBSTRUCTIONS
--------	--

**DIVISION 31 - EARTHWORK**

310000	EARTHWORK
312323.14	COMPACTED GRANULAR BACKFILL

**DIVISION 32 - EXTERIOR IMPROVEMENTS**

320190.33	TREE AND SHRUB PRESERVATION
321000	PAVEMENT REPLACEMENT
321216	ASPHALT CONCRETE PAVING AND MATERIALS
321613.13	CONCRETE CURBS
321623	CONCRETE WALKS AND STAIRS
329219	SEEDING

LEAD SERVICE LINE REPLACEMENTS

**DIVISION 33 - UTILITIES**

- 330533.23 HIGH DENSITY POLYETHYLENE (HDPE) PIPE AND FITTINGS
- 331113.02 LEAD SERVICE LINE REPLACEMENTS

SPECIAL REQUIREMENTS – EPA

WPCLF & WSRLA Projects	SR.EPA.1 – 5
MBE/WBE Utilization	SR. EPA.6 –
	SR.EPA.17
Violating Facilities	SR.EPA.18
SBRA	SR.EPA.19
WPCLF Local Protest Procedure	SR.EPA.20
Continuous Treatment Provisions	SR.EPA.21
WPCLF/WSRLA Payments	SR.EPA.22
WPCLF/WSRLA Contract Change Order	SR.EPA.23 –
	SR.EPA.24
Build America, Buy America	SR.EPA.25 –
	SR.EPA.45
Signage	SR.EPA.46 –
	SR.EPA.49
Buy American Requirements for Iron and Steel Products	SR.EPA.50 –
	SR.EPA.82
Prohibition on Telecommunications and Video Surveillance	SR.EPA.83

Davis-Bacon Wage Rate Requirements.....	DB.1 – DB.19
Davis-Bacon Prevailing Wage Schedule.....	Attached

Standard General Conditions [EJCDC C-700 (2007 Edition)].....	1 to 68
---	---------

Detailed Drawings:

1. Service Tie In for Inside Meters (SD-4-8)
2. Type A Pavement Replacement (SD-5-1)
3. Type C Pavement Replacement (SD-5-3)
4. Trenching, Embedment and Backfill Detail (SD-1-1)
5. Type A Walk Replacement (SD-5-7)
6. Expansion Joint (SD-5-9)
7. Curb Replacement Detail (SD-5-16)
8. Curb Ramp Details



LEAD SERVICE LINE REPLACEMENTS

**INVITATION TO BID**

Sealed bids for a unit price contract will be received by the CITY OF ELYRIA, OHIO, until 1:00 p.m. local time on September 13, 2024 for the project known as:

**LEAD SERVICE LINE REPLACEMENTS PROJECT  
PHASE 4, 2024**

**WSRLA FUNDED PROJECT**

The bids are to be delivered to the **Office of the Safety-Service Director, Elyria City Hall, 131 Court Street, Elyria, Ohio 44035**. All bids received will then be opened and read at a public bid-opening meeting.

**DESCRIPTION OF WORK:** The Contractor shall furnish all labor, equipment, supplies, and supervision of labors necessary to complete the work. This project consists of replacing lead service lines on either or both the public or private side of the right of way for addresses as noted. All explorations, excavation, completion of work, backfilling, restoration and final acceptance is included.

**BIDDING DOCUMENTS:** The bid specifications, drawings, plan holders list, addenda, and other bid information (**but not the bid forms**) may be viewed and/or downloaded for free via the internet at <https://bids.ctconsultants.com> . The bidder shall be responsible to check for Addenda and obtain same from the web site.

Bids must be in accordance with drawings and specifications and on forms available from CT Consultants, Inc. at a non-refundable cost of One Hundred Twenty-Five Dollars (\$125.00). Documents may be ordered by registering and paying online at <https://bids.ctconsultants.com> . Please contact [planroom@ctconsultants.com](mailto:planroom@ctconsultants.com) or call (440) 530-2351 if you encounter any problems viewing, registering or paying for the documents.

**BID SECURITY:** The bid must be accompanied by a bid guaranty. The bid guaranty must meet all requirements of Section 153.54 of the ORC and the Instructions to Bidders.

**COMPLETION DATES:**  
**SUBSTANTIAL: MAY 29, 2026**  
**RESTORATION: JUNE 26, 2026**

**PREVAILING WAGES:** The contractor and any subcontractor must comply with the prevailing wage rate requirements on public improvements in Lorain County and the City of Elyria, Ohio, as determined by the Federal Department of Labor under the Davis-Bacon Act. A complete listing of prevailing wage rates for Heavy/Highway work on public improvements in Lorain County is included in the bid documents.

LEAD SERVICE LINE REPLACEMENTS

**COMPLIANCE WITH ALL LAWS:** All work shall be carried out in compliance with all federal, state and local laws, rules and regulations that apply to the work. Any project specification item in conflict with a federal, state, or local law, rule or regulation, shall be void.

**AFFIRMATIVE ACTION:** All bidders must comply with the provisions of Chapter 167 of the Elyria Codified Ordinances as amended. Bidders must be pre-certified or submit an acceptable Affirmative Action Plan with the bid submission. Prospective bidders may contact the City's Equal Opportunity Representative at (440) 326-1421 for information on pre-certification. No contract will be awarded unless an acceptable Affirmative Action Plan is reviewed by the EEO Office, approved and incorporated into the contract. Each bidder must complete and sign the Elyria Equal Opportunity Clause, which is included with the specifications.

**PROPOSAL FORMS:** No proposal will be considered unless it is made on the blanks furnished by the City. No bidder shall take any exception to any requirement of the specifications. Each proposal must contain the full name of the party or parties submitting the proposal and all persons interested therein.

**AWARD OF CONTRACT:** The City reserves the right to waive any technicalities or informalities, to reject any or all bids received, and to accept any bid with any combination of alternates which is deemed most favorable to the City of Elyria, Ohio at the time and under the conditions stipulated in the project documents.

This project will be funded by the Water Supply Revolving Loan Account Program as administered by the Ohio Environmental Protection Agency and the Ohio Water Development Authority. The Contractor shall note that there are Disadvantaged Business Enterprise participation goals for this project.

This procurement is subject to the EPA policy on encouraging the participation of small business in rural areas (SBRAs).

Frank Whitfield  
Mayor

*Chronicle-Telegram*

August 30, 2024

September 6, 2024

## INSTRUCTIONS TO BIDDERS

### 1. ORDINANCE

- 1.1 The bids for this project are being taken in accordance with Ordinance No. 2022-174, passed by the Elyria City Council on October 17, 2022.

### 2. DEFINED TERMS

- 2.1 Except as given in Section 2.2 herein, the terms used in these Instructions to Bidders which are defined in the General Conditions, and have the meanings assigned to them in Section 1.01 of the noted General Conditions.

- 2.2 Additional terms used in these Instructions to Bidders are defined as follows:

**SUCCESSFUL BIDDER** - the lowest and best, responsible, and responsive bidder to whom the City (on the basis of the City's evaluation as hereinafter provided) makes an award.

**UNDERGROUND FACILITIES** - All pipes, conduits, ducts, cables, fiber optic cables, wires, service connections, manholes, closeouts, valves, vaults, pull boxes, tanks, tunnels, culverts or other such facilities or attachments, and encasements containing such facilities privately or publicly owned which have been installed underground to furnish any of the following services or materials: electricity, gas, steam, liquid petroleum products, street lighting, telephone or other communications, cable television, sewage and drainage removal, traffic or other control systems, or water.

**WORK** - The entire completed construction or the various separately identifiable parts thereof required to be furnished under the contract documents. Work includes and is the result of performing or furnishing labor and furnishing and incorporating materials and equipment into the construction, and performing or furnishing services and furnishing documents, all as required by the contact documents.

### 3. COPIES OF BIDDING DOCUMENTS

- 3.1 Complete sets of the bidding documents may be purchased from CT Consultants for the payment of the fee stated in the Invitation to Bid. No refund will be made for returned documents.
- 3.2 Complete sets of bidding documents must be used in preparing bids; the City does not assume any responsibility for errors or misinterpretations resulting from the use of incomplete set of bidding documents.
- 3.3 The City in making copies of the bidding documents available on the above terms does so only for the purpose of obtaining bids for the work and does not confer a license or grant permission for any other use of the bidding documents.

**4. QUALIFICATIONS OF BIDDERS**

- 4.1 To demonstrate qualifications to perform the work, each bidder must be prepared to submit within five (5) days after the bid opening, upon the City's request, detailed written evidence such as financial data, previous experience, present commitments and other such data as may be needed to demonstrate the bidder's qualifications.
- 4.2 Each bidder must be qualified to do business in the State of Ohio, or must obtain such qualification prior to award of the contract by the City.

**5. EXAMINATION OF CONTRACT DOCUMENTS AND SITE**

- 5.1 It is the responsibility of each bidder before submitting a bid:
  - 5.1.1 To examine thoroughly the contract documents and other related data identified in the bidding documents;
  - 5.1.2 To visit the site to become familiar with and satisfy bidder as to the general, local and site conditions that may affect cost, progress, performance or the furnishing of the work;
  - 5.1.3 To consider federal, state and local laws and regulations that may affect cost, progress, performance, or the furnishing of the work;
  - 5.1.4 To study and carefully correlate bidders knowledge and observations with the contract documents, and other related data;
  - 5.1.5 To promptly notify the Engineer of all conflicts, errors, ambiguities or discrepancies which bidder has discovered in or between the contract documents and other related documents or observations.
  - 5.1.6 To evaluate the condition, layout and nature of the project site and surrounding area;
  - 5.1.7 To consider the availability and cost of labor;
  - 5.1.8 To consider the availability and cost of materials, supplies and equipment;
  - 5.1.9 To consider the cost of temporary utilities required in the bid;
  - 5.1.10 To consider the cost of any permit or license required by a local or regional authority having jurisdiction over the project;
  - 5.1.11 To consider the generally prevailing climatic conditions; and
  - 5.1.12 To evaluate conditions bearing upon transportation, disposal, handling, and storage of materials.

## LEAD SERVICE LINE REPLACEMENTS

- 5.2 All notices of conflicts, errors, ambiguities or discrepancies submitted by a bidder to the Engineer must be in writing and should be given at least seven (7) days prior to the bid opening. The Engineer will respond to such notices received in time, by sending an addendum to all holders of the plans and specifications.
- 5.3 Any reports of exploration and tests of subsurface conditions at or contiguous to the site which have been utilized by the Engineer in preparation of the contract documents are identified in the Supplementary Conditions. The bidder may rely upon the general accuracy of the "technical data" contained in such report but not upon other data, interpretations, opinions or information contained in such reports or otherwise related to the subsurface conditions at the site, nor upon the completeness thereof for the purpose of bidding or constructing the project.
- 5.4 The City may have record drawings of previous projects constructed in the past, in part or all of the site where this project is to be constructed. The bidder may examine these drawings but the City is not responsible for the accuracy thereof.
- 5.5 The bidder may purchase copies of the reports noted in Section 5.3 and of the drawings noted in Section 5.4 for the cost of reproduction as established by City Ordinance. Those reports and drawings are not part of the contract documents. The bidder is responsible for any interpretation or conclusion drawn from any technical data, opinions or other information contained in or developed from such reports or drawings.
- 5.6 Before submitting a bid each bidder will be responsible to obtain such additional or supplementary examinations, investigations, explorations, tests, studies, and data concerning conditions (surface, subsurface, and underground facilities) at or contiguous to the site or otherwise which may affect cost, progress, performance, or furnishing the work, or which relates to any aspect of the means, methods, techniques, sequences, or procedure of construction to be selected and employed by bidder and all safety precautions and programs incidental thereto or which bidder deems necessary to determine its bid for the performing and furnishing the work in accordance with time, price, and other terms and conditions of the contract documents.
- 5.7 On request, the City will grant permission to each potential bidder, access to the site (by issuing a no fee excavation permit, except a fee will be required if pavement is to be cut) to conduct such examination, investigation, exploration, tests and studies as each bidder deems necessary for submission of a bid. Bidders must fill all test holes and clean up and restore the site to its former condition upon completion of such explorations, investigation, tests and studies.
- 5.8 The general nature of any work scheduled to be performed at the project site by the City, or by another prime contractor working for the City, and by any utility (if known by the City) that relates to the work for which a bid is to be submitted, is included as information in the Supplementary Conditions.

## LEAD SERVICE LINE REPLACEMENTS

- 5.9 The submission of a bid will constitute an incontrovertible representation by bidder that bidder has complied with every requirement of this Article 5, and that without exception the bid is premised upon performing and furnishing the work required by the contract documents and applying the specific means, methods, techniques, sequences or procedures of construction selected by the bidder to complete the project as expressly required by the contract documents, that the bidder has given the Engineer written notice of all conflicts, errors, ambiguities and discrepancies that bidder has discovered (if any) in the contract documents in time for an addenda to be issued to all plan holders, and that the written resolutions thereof issued by the Engineer as an addenda is acceptable to the bidder, and that the contract documents are generally sufficient to indicate and convey understanding of all terms and conditions for performing and furnishing the work.

### **6. AVAILABILITY OF LAND FOR WORK**

- 6.1 The lands upon which the work is to be performed, the right-of-way and easements, and access thereto and other lands designated for use by the contractor in performing the work are identified in the contract documents. All additional lands and access thereto required for temporary construction facilities, construction equipment, or storage of materials and equipment to be incorporated in the work are to be obtained and paid for by the contractor.
- 6.2 All easements and/or right-of-way for permanent structures or permanent changes in existing facilities have been or will have been obtained and paid for by the City prior to the issuance of the notice to commence.
- 6.3 Any special condition set forth in easements obtained by the City which may affect the performance or furnishing the work, if any, are identified in the Supplementary Conditions.

### **7. INTERPRETATIONS AND ADDENDA**

- 7.1 All questions about the true meaning or intent of the bidding documents are to be directed to the Engineer, CT Consultants Interpretations or clarifications considered necessary by the Engineer, CT Consultants in response to such questions will be issued by addenda, either emailed, mailed, faxed or hand delivered to all parties recorded by the Engineer, CT Consultants as having received the bidding documents.
- 7.2 Any addenda may also be issued by the Engineer, CT Consultants to modify the bidding documents as deemed advisable by the City. The bidder shall be responsible to obtain Addenda from the web at <https://bids.ctconsultants.com>.
- 7.3 Any bidder may not rely upon any interpretation of the bidding documents by any means other than a written addendum.

LEAD SERVICE LINE REPLACEMENTS

**8. BID SECURITY**

- 8.1 Each bid must be accompanied by a bid guarantee. The bid guarantee may be either a **Bid/Contract Bond, Certified Check, Cashiers Check** or a **Letter of Credit**. The bid guarantee shall meet all requirements of Section 153.54 of the Ohio Revised Code and any additional requirements stated herein.
- 8.2 Any bond shall be furnished by a surety company licensed to conduct business in the State of Ohio. Any check used as bid security shall be drawn on a solvent bank.
- 8.3 Any **Bid/Contract Bond** submitted shall be for the full amount of the base bid plus the highest combination of additive alternates, if any. The form of the **Bid/Contract Bond** shall be of substantially the same form as provided in Section 153.571 of the Ohio Revised Code and it shall serve as both a bid bond and a contract bond. If stated, the amount of the **Bid/Contract Bond** shall be specified in figures. Specifying the amount of the bond as a percentage or one hundred percent (100%) is not acceptable.
- 8.4 Section 3905.41, Ohio Revised Code, may require that a **Bid/Contract Bond** be countersigned by an Ohio resident agent. It is the bidder's responsibility to determine the applicability of Section 3905.41, Ohio Revised Code.
- 8.5 Any **Certified Check, Cashiers Check** or a **Letter of Credit** submitted shall be made payable to the City of Elyria Ohio, and shall be for an amount of not less than ten percent (10%) of the sum of the base bid plus the highest combination of additive alternates, if any. The amount shall be stated in figures. Any **Certified Check, Cashiers Check** or a **Letter of Credit** submitted shall be accompanied by an executed Consent of Surety form. Any letter of credit shall be revocable only by the City. If the successful bidder used a certified check, cashier's check or letter of credit, it will be returned upon provision of the **Contract Bond** required by Section 153.54, Ohio Revised Code.
- 8.6 In case a bidder, to whom a contract is awarded, fails to execute the contract within ten (10) days after notice of award is delivered in writing to the bidder, or in case a bidder fails to secure the contract with an acceptable performance bond and payments bond (each in the full amount of the contract) and execute the contract within ten (10) days after notice of the award is delivered in writing to the bidder, the bidder shall be considered as refusing the contract and shall forfeit their bid security in accordance with provisions of Section 153.54 of the Ohio Revised Code.
- 8.7 The bid security from each bidder may be held by the City for up to sixty (60) days. The bid security will be returned to the unsuccessful bidders after the contract has been signed and secured as provided herein above by the successful bidder.

**9. CONTRACT TIME**

- 9.1 The number of days within which, or the date by which, the work is to be substantially completed and also completed and ready for a pre-final payment, are set forth in the Invitation to Bidders and will be set forth in the Agreement Form.

**10. LIQUIDATED DAMAGES**

10.1 Provisions for liquidated damages, if any are set forth in the Agreement Form.

**11. SUBSTITUTE AND "OR-EQUAL" ITEMS**

11.1 The drawings or specifications may make a reference to a specific manufacturer's make or model identification for a material or item of equipment. The materials and equipment described in this way, by a manufacturer's brand name, establishes a standard of required type, function, quality, expected life to be met by any proposed substitute or "or-equal" item. Such reference to a name shall be considered as requiring the contractor to furnish either that product or a substitute proposed by the contractor and approved by the Engineer as an approved equal.

11.2 An application for acceptance will not be considered by the Engineer until after the effective date of the Agreement.

11.3 Each submission by the contractor for review of a substitute shall include the name of the material or equipment for which it is to be substituted and a complete description of the proposed item including drawings, cuts, performance and test data, and any other information necessary for an evaluation.

11.4 The Engineer's review of the substitution will consider the City's normal inventory of repair parts for the specified equipment and the possibility of increased down time for repairs to equipment of a type that repair parts are not in the City's inventory.

**12. BID FORM**

12.1 The Bid Form is included with the bidding documents. This form shall be used by the bidder to submit its bid.

12.2 All blanks on the Bid Form (except the signature line) must be completed by printing in black or blue ink or by typewriter.

12.3 Discrepancies between the sum of the labor bid price and the material bid price for an item will be resolved by using the total bid price stated by the bidder.

12.4 Bids by entities must be executed by an authorized officer, member, partner, or the equivalent and accompanied by evidence of authority to sign.

12.5 Bids by a partnership must be executed in the partnership name and signed by a partner, whose title must be shown below the signature.

12.6 The bid shall contain an acknowledgment of receipt of all addenda.

12.7 The address and telephone number for communication regarding the bid must be shown.



## LEAD SERVICE LINE REPLACEMENTS

- 12.8 An out-of-state entity must provide evidence of authority to conduct business in the State of Ohio.
- 12.9 The bid price stated in the bid form shall be the full price for completion of the work which price shall include all payments by the City to the contractor for all labor, material, equipment, supervision, and overhead required to complete the work.
- 12.10 The cost of completing all work specified in the drawings and in the specifications, in accordance with the contract documents, shall be included by the bidder in the pay items listed on the Bid Form.
- 12.11 The quantities of the work itemized in the bid are approximate only and the bidders are hereby notified that the estimated quantities made by the Engineer are merely for the guidance of the Owner in comparing on a uniform basis all bids received for the work. The Owner may increase or decrease the quantities and alter the Work as necessary to complete the project.

### **13. SUBMISSION OF BIDS**

- 13.1 Bids shall be submitted at the time and place indicated in the Invitation to Bidders and shall be bound with the other bidding documents, and enclosed in an opaque sealed envelope marked "**BID ENCLOSED**" for project (by name) plus the name and address of the bidder.
- 13.2 If the bid is sent through the mail or delivered by another delivery system, the sealed bid envelope shall be enclosed in a separate envelope with the notation "**BID ENCLOSED**" on the face of the delivery envelope. Bids received, if any, after the deadline for delivery of bids, will be returned unopened.

### **14. NO MODIFICATION OF BIDS**

- 14.1 After submission of a bid to the City, no modification of the bid may be made by the bidder.

### **15. WITHDRAWAL OF BIDS**

- 15.1 After submission of a bid to the City, and at any time before the deadline for bid submission, the bidder may withdraw its bid by giving a duly signed written notice requesting to withdraw the bid to the City. Thereafter, that bidder will be disqualified from further bidding on the work, including any re-bid held by the City.

### **16. OPENING OF BIDS**

- 16.1 All bids received will be opened and (unless obviously non-responsive) read aloud publicly at the place where the bids are to be submitted. A summary of the prices bid will be mailed to all bidders after a tabulation of the bids is completed by the Engineer.

**17. BIDS TO REMAIN SUBJECT TO ACCEPTANCE**

- 17.1 All bids will remain subject to acceptance for sixty (60) days after the day of the bid opening, but the City may, in its sole discretion, release the bid and return the bid security prior to the end of the sixty (60) day period.

**18. AWARD OF CONTRACT**

- 18.1 The City reserves the right to reject any or all bids, including without limitation, the rights to reject any or all nonconforming, non-responsive, unbalanced or conditional bids, and to reject the bid of any bidder if the City believes that it would not be in the best interest of the City to make an award to that bidder, whether because the bid is not responsive or the bidder is unqualified or of doubtful financial ability or fail to meet any other pertinent standard or criteria established by the City.
- 18.2 In evaluating the bids to determine the lowest and best bid, the City will consider the qualification of the bidders, whether or not the bids comply with the prescribed requirements, and such alternates, unit prices and other data, as may have been submitted with the bid or as may be requested per the contract documents before the award is made by the City.
- 18.3 The City may consider the qualifications and experience of the subcontractors, suppliers, and other persons and organizations proposed for those portions of the work as to which the identity of subcontractors, suppliers, and other persons and organizations must be submitted as provided in the Supplementary Conditions. The City may consider also the operating cost, maintenance requirements, performance data and guarantees of major items of materials and equipment proposed for incorporation in the work when such data is required to be submitted prior to the award of the work.
- 18.4 The City may conduct such investigations as the City deems necessary to assist in the evaluation of any bid and to establish the responsibility, qualifications and financial ability of the bidders, proposed subcontractors, suppliers, and other persons and organizations to perform and furnish the work in accordance with the contract documents to the City's satisfaction within the prescribed time.
- 18.5 If the contract is to be awarded, it will be awarded to the bidder whose evaluation by the City indicates to the City that the award will be in the best interest of the City.
- 18.6 If the contract is to be awarded, the City will give the successful bidder a Notice of Award within sixty (60) days after the day of the bid opening, unless the bidder grants a time extension to the City.
- 18.7 The lowest bidder shall be determined by the City adding the Base Bid and any combination of the Add Alternates.

**19. SIGNING OF AGREEMENT**

- 19.1 When the City gives a written Notice of Award to the successful bidder, it will be accompanied by the required number of the unsigned counterparts of the Agreement. Within ten (10) days thereafter the contractor shall sign the Agreement and deliver all copies to the Engineer. The City will then execute the Agreement, and the City Finance Director's Certification of Funds, and will deliver one (1) fully executed Agreement to the contractor with the Notice to Commence Work. One copy of the Agreement and attached documents will be sent to the local agent of the contractor's surety.

**20. CONTRACT SECURITY**

- 20.1 When the successful bidder delivers the executed Agreement to the City, it must be accompanied by the required performance and payment bonds, unless the bond submitted with the bid was a **Bid/Contract Bond** which will serve as the required contract security.

**21. SALES TAXES**

- 21.1 The City is exempt from Ohio State sales and use taxes on the materials and equipment to be incorporated into the work. Said taxes shall not be included in the bid price. The contractor shall contact the City Finance Director's Office for completion of the tax-exempt forms required for the project.

**22. PROGRESS PAYMENTS AND RETAINER (E.C.O. 143.06)**

- 22.1 Progress payments may be made to a Contractor before the work is completed. Progress payments so paid to a Contractor shall be based on actual measurements of labor and materials furnished, including materials delivered, under the contract to the date of estimate. The amount of a progress payment shall be determined by subtracting from the value of the portion of the work completed and materials furnished to the date of the estimate a retainer of ten percent (10%) and the sum of all previous progress payments.
- 22.2 Thirty (30) days after substantial completion of the work under the contract, and upon approval of the work by the Engineer, the ten percent (10%) retainage may be reduced to five percent (5%).
- 22.3 After completion of all punch list items, the five percent (5%) retainage may be released. The Contractor shall be responsible for full guaranty of work for complete one year from the date of final completion of the contract. No retainer shall be subject to interest payments to the Contractor nor required to be deposited with an escrow agent who will pay interest to the Contractor.

**23. EQUAL EMPLOYMENT OPPORTUNITY**

- 23.1 In addition to the City of Elyria, Ohio, Codified Ordinance Chapter 167, the contractor shall, and all subcontractors working on the project shall, comply with the equal employment requirements for the utilization of minorities and females pursuant to Chapter 123 of the Ohio Administrative Code, the Governor's Executive Order of 1972, and the Governor's Executive Order 84-9.

**24. SPECIAL INSURANCE REQUIREMENTS**

- 24.1 The contractor and each of the subcontractors shall maintain during the life of its contract or subcontract, Workers' Compensation Insurance, Public Liability, Property Damage and Vehicle Liability Insurance, equal or exceeding the limits specified in the Supplementary Conditions.

**25. CONTRACTOR LICENSES**

- 25.1 The Contractor and all Subcontractors shall obtain, maintain and renew the necessary licenses as required by the City of Elyria Building Department to complete the Work. The Contractor shall secure all credentials and pay for all necessary fees associated with obtaining these licenses. Fees shall be included in the price of the contract and no additional payment will be made to the Contractor for reimbursement of fees. Licenses shall be obtained prior to initiating any construction activity associated with that particular license.

**26. STORMWATER BEST MANAGEMENT PRACTICES**

- 26.1 The Contractor and all Subcontractors shall consider and implement any and all storm water best management practices (BMPs) as per City of Elyria Codified Ordinance Chapter 960 "Storm Water Management" and as per the Ohio Department of Natural Resources in the most recent version of the Rainwater and Land Development manual for construction site runoff and post-construction site runoff as required to minimize, reduce and/or eliminate the discharge of contaminated or sediment-laden storm water from the construction site. All existing and proposed outlets and drainage courses shall be protected.
- 26.2 The Contractor shall develop and submit a plan for approval to the Engineer. Weekly site inspections, including all inspections within 24 hours after a rain event, shall be the responsibility of the contractor. Completed and signed inspection forms shall be submitted to the Engineer within 48 working hours after the completion of the inspection. Maintenance of all BMPs shall be the responsibility of the contractor. The contractor and all of its subcontractors shall comply with all other storm water best management practices. Cost for this work shall be included in pertinent unit price bid items. No separate payment will be made.

## AGREEMENT FORM

CONTRACT NO. \_\_\_\_\_

This agreement is dated the \_\_\_\_\_ day of \_\_\_\_\_ 20\_\_, by and between the City of Elyria, Ohio, an Ohio Municipal Corporation 131 Court St., Elyria, Ohio 44035 “City” and \_\_\_\_\_, \_\_\_\_\_, Ohio \_\_\_\_\_, “Contractor”. This Agreement was authorized by Ordinance No. 2021-42 passed by the Elyria City Council on 3-1-2021.

**The City and the Contractor, in consideration of the mutual covenants hereinafter set forth, agree as follows:**

### ARTICLE 1 – WORK

The Contractor shall furnish all labor, equipment, supplies, and supervision of labors necessary to complete the work. This project consists of replacing lead service lines on either or both the public or private side of the right of way for addresses as noted. All explorations, excavation, completion of work, backfilling, restoration and final acceptance is included.

### ARTICLE 2 - ENGINEER TO BE CITY'S REPRESENTATIVE

The services of the Contractor shall be carried out under the authority for contract administration of the Mayor and Safety-Service Director of the City, who is designating the Engineer as the person who will administer the contract, and who will for the City undertake and assume all duties and responsibilities, and who will have the authority and rights assigned to the Engineer under the specifications for this work.

### ARTICLE 3 - CONTRACT TIME

The **Contractor** agrees that the **Work** under this contract will be completed:

**SUBSTANTIAL: MAY 31, 2026**

**RESTORATION: JUNE 30, 2026**

### ARTICLE 4 - LIQUIDATED DAMAGES

The City and the Contractor recognize that time is of the essence in this agreement, and that the City will suffer financial loss (including but not limited to incidental and consequential damages) if the work is not carried out within the time specified in Article 3 herein. Both the City and the Contractor recognize the impossibility of calculating the actual loss suffered by the City if the work is not substantially completed within the specified time. Accordingly, instead of requiring any such proof, the City and the Contractor agree that as liquidated damages for delay (but not as a penalty) the Contractor shall pay the City the sum of one thousand dollars (\$1,000.00) for each calendar day that expires after the time specified in Article 3 herein for completing the work assigned, unless the City grants a time extension for good reason not under the control of the Contractor. In addition to the foregoing, Contractor agrees to pay for the cost of any additional inspection services that the City requires as a result of delays.

**ARTICLE 5 - CONTRACT SUM**

The City shall pay the Contractor for performance of the work, in accordance with the contract documents, in current funds at the fixed price stated in the Contractor's bid for the base bid and alternates awarded, if any, unless the work is revised by written change order executed by the Mayor for the City and the Contractor.

For the work as awarded to the Contractor, the total amount to be paid by the City to the Contractor shall not exceed,

\_\_\_\_\_ (\$\_\_\_\_\_).  
(Amount in Words) (Amount in Figures)

**The Contractor agrees that no extra work will require an extra payment by the City, unless the extra work is authorized in a written change order executed by the City's Mayor before the work is carried out.**

**ARTICLE 6 - PAYMENT PROCEDURES**

The Contractor agrees to promptly (by the 5th of each month), but not more frequently than once every thirty (30) days, submit an original invoice with one (1) copy and the required estimate computations with required certifications to the Engineer. City will make progress payments on or about the 26<sup>th</sup> day of each month.

Prior to substantial completion, progress payments will be in an amount equal to ninety percent (90%) of the work completed and ninety percent (90%) of the materials and equipment delivered to the project site, but not yet incorporated into the work, less in each case, the aggregate of all payments previously made. No retainer shall be subject to interest payments to the Contractor nor required to be deposited with an escrow agent who will pay interest to the Contractor.

**Acceptance of the Work, Pre-Final Payment and Final Payment:** Upon final completion and acceptance of the work by the City in accordance with E.C.O. 143.06, the City shall pay the Contractor all funds due the Contractor, except for the five percent (5%) retainer per Section 22 of the Instructions to Bidders. The five percent (5%) retainer shall be paid by the City to the Contractor, after completion of all work and all punch list items. If defects in the work are found during the one (1) year period, the defects are to be corrected by the Contractor. The corrected work shall be guaranteed for a period of one (1) year by the Contractor. After satisfactory completion of all work and all punch list items, the five percent (5%) retainer or any payment withheld for other purpose may be released.

**ARTICLE 7 - CONTRACTOR'S REPRESENTATIONS**

The Contractor acknowledges that it has taken the steps reasonably necessary to ascertain the nature and the location of the work, and that it has investigated and satisfied itself as to the general and local conditions which can affect the work, its cost, including but not limited to (1) the cost of purchasing, transportation, handling and storage of materials and supplies, (2) the availability of labor and cost, (3) the uncertainties of weather or similar physical conditions, including the time of year the project

## LEAD SERVICE LINE REPLACEMENTS

is to be constructed, (4) all other physical conditions which can impact the cost of doing work, (5) the character of the equipment and facilities needed to prepare to do the work and to carry out the work to be performed, considering the limited work area, and the access to the site, (6) the cost of the Contractor's overhead, (7) the cost of providing worker supervision and management, (8) the cost of providing insurance, bonds, and related expenses.

The Contractor also acknowledges that it has had sufficient time during the bidding of the project to review all contract documents, and to make all investigations necessary to reasonably ascertain the cost of doing the work. Further, the Contractor has correlated the results of observations, examination, investigations, and review of local labor conditions with the terms and conditions of all of the contract documents, including the addenda listed on the Contractor's Bid Form, in determining the price bid for the work. The Contractor acknowledges that the City assumes no responsibility for any understanding reached or representations made concerning conditions which can affect the work, by any of its officers, employees, or agents before execution of this Agreement, unless that understanding or representation is expressly stated in the contract documents which are a part of the Agreement.

### **ARTICLE 8 - INDEMNIFICATION**

Contractor shall indemnify, defend and hold harmless the City of Elyria (ELYRIA), its elected officials, employees, representatives and agents (the Indemnified Parties) from and against any and all loss, cost, expense, damage, injury, liability, claim, demand, penalty or cause of action (including attorneys' fees) directly or indirectly arising out of, resulting from or related to (in whole or in part), (1) the work performed hereunder, (2) the contract or (3) the act or omission of Contractor, a Subcontractor or any individual partnership or joint venture or corporation (a) directly or indirectly employed by Contractor or a Subcontractor or (b) for whose acts or omissions Contractor or a Subcontractor may be liable. Contractor shall promptly advise Elyria in writing of any action, administrative or legal proceeding or investigation as to which this indemnification may apply, and Contractor, at Contractor's expense shall assume on behalf of Elyria and conduct with due diligence and in good faith the defense with counsel satisfactory to Elyria, provided, that Elyria shall have the right to be represented therein by advisory counsel of its own selection and at its own expense; and provided further, that if the defendants in any such action include both Contractor and Elyria, and Elyria shall have reasonably concluded that there may be legal defenses available to Elyria which are different from or additional to, or inconsistent with those available to Contractor, Elyria shall have the right to select separate counsel to participate in a defense of such action on its own behalf at Contractor's expense. In the event of failure by Contractor to fully perform in accordance with this indemnification, Elyria, at its option, and without relieving Contractor of its obligations hereunder may so perform, but all costs and expenses so incurred by Elyria in that event shall be reimbursed by Contractor to Elyria, together with interest on the same from the day any such expense was paid by Elyria until reimbursed by Contractor at the rate of interest provided to be paid on judgments, by the law of the State of Ohio. The obligations of Contractor under this Section shall survive the expiration of the Contract.

## LEAD SERVICE LINE REPLACEMENTS

In claims against any of the Indemnified Parties by an employee of the Contractor, a Subcontractor, anyone directly or indirectly employed by them or anyone for whose acts or omissions they may be liable, the indemnification obligation under this Section shall not be limited by a limitation on the amount or type of damages, compensation or benefits payable by or for the Contractor or Subcontractor under workers' compensations acts, disability benefits acts, or other employee benefit acts.

### **ARTICLE 9 - CONTRACT DOCUMENTS**

The contract documents, including the Bid Form, Instructions to Bidders, Invitation to Bid, all Addenda listed on the Contractors Bid Form, the General Conditions, Federal Davis-Bacon Prevailing Wages, OEPA/DEFA documents, and Technical Specifications, and as prepared by the Engineer, and all attachments submitted by the Contractor with its Bid Form, are made a part of the Agreement hereto as if the contents of those contract documents were repeated in full herein. The City and the Contractor agree that there are no contract documents, other than those identified in this Article 9.

### **ARTICLE 10 - ASSIGNMENT**

No assignment by a party hereto of any rights under or interests in the Agreement will be binding on another party hereto without the written consent of the party sought to be bound; and specifically but without limitation, moneys that may become due and moneys that are due may not be assigned without such consent (except to the extent that the effect of this restriction may be limited by law), and unless specifically stated to the contrary in any written consent to an assignment. No assignment will release or discharge the assignor from any duty or responsibility under the contract documents.

### **ARTICLE 11 - SAFETY**

The Contractor agrees to comply with Chapter 4121:1-3 of the Ohio Administrative Code entitled "Specific Safety Requirements of the Industrial Commission of Ohio relating to Construction", effective November 1, 1979 and with the "Federal Occupational Safety and Health Act of 1970 and Code of Federal Regulation, Title 29, Chapter XVII, Part 1926", and to also comply with all other requirements of law.

### **ARTICLE 12 - PREVAILING WAGE RATES**

The Contractor agrees to pay wages equal to or exceeding the minimum wage rates as determined by the Federal Davis-Bacon Act. The Contractor agrees to require all subcontractors, if any, to pay wages equal to or exceeding the minimum wage rates as determined by the Federal Department of Labor.

### **ARTICLE 13 - SUCCESSORS**

The City and the Contractor each bind themselves, their partners, successors, assigns and legal representatives in respect to all conveniences, agreements and obligations contained in the contract documents.



**ARTICLE 14 - OTHER PROVISIONS**

The Contractor agrees to comply with the requirements of Chapter 167 of the Elyria Codified Ordinances as amended, regarding Affirmative Action and Equal Employment Opportunity. All sections of Chapter 167 as amended on the first date of advertising this project, which are to be a part of any construction or service agreement executed by the City, are included in this Agreement by reference, as if repeated in full herein.

**ARTICLE 15 – GOVERNING LAW:**

This agreement shall be construed and interpreted under the laws of the State of Ohio.

**ARTICLE 16 – OHIO REVISED CODE:**

CONTRACTOR shall comply with all applicable provisions of Sections 2909.21 to 2909.34 Ohio Revised Code (Ohio Patriot Act) and Sections 3517.13 Ohio Revised Code.

**IN WITNESS WHEREOF, the parties hereto have as of the \_\_\_\_\_ day of \_\_\_\_\_, 20\_\_, signed this Agreement and one (1) counterpart.** (The original will be held by the City Safety-Service Director. One counterpart will be delivered to the Contractor and copies to the Contractor's Surety (local agent), City Finance Director, and City Engineer.)

**NAME OF COMPANY**

By: \_\_\_\_\_ Title: \_\_\_\_\_  
(Printed Name)

By: \_\_\_\_\_ Witness: \_\_\_\_\_  
(Signature) (Signature)

**THE CITY OF ELYRIA, OHIO**

By: Hon. Frank Whitfield, Mayor Date: \_\_\_\_\_

By: \_\_\_\_\_ Witness: \_\_\_\_\_  
(Signature) (Signature)

**APPROVED AS TO FORM:**

By: \_\_\_\_\_ Date: \_\_\_\_\_  
Amanda Deery, Law Director

**NOTICE TO COMMENCE WORK  
and  
NOTICE TO COMMENCEMENT OF A PUBLIC IMPROVEMENT  
PURSUANT TO REVISED CODE SECTION 1311.252**

State of Ohio

SS

County of Lorain

I, Frank Whitfield, being first duly sworn, says that:

- 1) Affiant is the Mayor of the City of Elyria, Ohio.
- 2) The City of Elyria, Ohio gives this Notice to Commence Work to the Contractor, for the public improvement of the **LEAD SERVICE LINE REPLACEMENTS PROJECT, PHASE 4, 2024.**
- 3) The following is the name, address and trade of the principal contractor working on this public improvement:

NAME:  
 ADDRESS:  
 TRADE:  
 DATE OF FIRST EXECUTED CONTRACT:

- 4) The following is the name and address of the surety for the principal contractor:

NAME OF SURETY:  
 ADDRESS OF SURETY:

- 5) For the purpose of serving an affidavit pursuant to Revised Code Section 1311.26, service may be made upon the following representative of the Public Authority:

Frank Whitfield, Mayor  
 CITY OF ELYRIA, OHIO  
 131 Court Street  
 Elyria, Ohio 44035

FURTHER AFFIANT SAYETH NAUGHT.

Signature: \_\_\_\_\_

SWORN TO BEFORE ME and subscribed in my presence this \_\_\_\_\_ day of \_\_\_\_\_, 20\_\_.

(SEAL)

Notary Public: \_\_\_\_\_

**FINANCE DIRECTOR'S CERTIFICATION OF FUNDS**

I hereby certify that there is in the Treasury of the City of Elyria, State of Ohio, to the credit of the \_\_\_\_\_, and not appropriated for any other purpose and/or in the process of collection, as required by law, the sum of \_\_\_\_\_ and \_\_\_\_\_ cents (\$\_\_\_\_\_ ) to pay the cost of the attached contract for the **LEAD SERVICE LINE REPLACEMENTS PROJECT, PHASE 4, 2024** in Elyria, Ohio.

Executed in duplicate this \_\_\_\_\_ day of \_\_\_\_\_ in the year of 20\_\_.

\_\_\_\_\_  
City Finance Director

Ordinance No.: \_\_\_\_\_

Passed by the Elyria City Council on \_\_\_\_\_

Account No.:

Account No.:

**Disadvantaged Business Enterprise (DBE) Program  
DBE Subcontractor Performance Form**

This form is intended to capture the DBE<sup>1</sup> subcontractor's<sup>2</sup> description of work to be performed and the price of the work submitted to the prime contractor. An EPA Financial Assistance Agreement Recipient must require its prime contractor to have its DBE subcontractors complete this form and include all completed forms in the prime contractors bid or proposal package.

Subcontractor Name		Project Name	
Bid/ Proposal No.	Assistance Agreement ID No. (if known)	Point of Contact	
Address			
Telephone No.		Email Address	
Prime Contractor Name		Issuing/Funding Entity:	

Contract Item Number	Description of Work Submitted to the Prime Contractor Involving Construction, Services, Equipment or Supplies	Price of Work Submitted to the Prime Contractor
DBE Certified By: <input type="radio"/> ODOT <input type="radio"/> DAS/EDGE <input type="radio"/> Other: _____		Meets/ exceeds EPA certification standards? <input type="radio"/> YES <input type="radio"/> NO <input type="radio"/> Unknown

**Check Which One Applies:**    \_\_\_\_\_ MBE    \_\_\_\_\_ WBE    (Include MBE/WBE Certificates, No DBE Certs)

<sup>1</sup> A DBE is a Disadvantaged, Minority, or Woman Business Enterprise that has been certified by an entity from which EPA accepts certifications as described in 40 CFR 33.204-33.205 or certified by EPA. EPA accepts certifications from entities that meet or exceed EPA certification standards as described in 40 CFR 33.202.

<sup>2</sup> Subcontractor is defined as a company, firm, joint venture, or individual who enters into an agreement with a contractor to provide services pursuant to an EPA award of financial assistance.

**FORM 6100-3 (DBE Subcontractor Performance Form)**

**Disadvantaged Business Enterprise (DBE) Program  
DBE Subcontractor Performance Form**

I certify under penalty of perjury that the forgoing statements are true and correct. Signing this form does not signify a commitment to utilize the subcontractors above. I am aware of that in the event of a replacement of a subcontractor, I will adhere to the replacement requirements set forth in 40 CFR Part 33 Section 33.302 I.

<b>Prime Contractor Signature</b>	<b>Print Name</b>
<b>Title</b>	<b>Date</b>

<b>Subcontractor Signature</b>	<b>Print Name</b>
<b>Title</b>	<b>Date</b>

**Disadvantaged Business Enterprise (DBE) Program  
DBE Subcontractor Utilization Form**

This form is intended to capture the prime contractor's actual and/or anticipated use of identified certified DBE<sup>1</sup> subcontractors<sup>2</sup> and the estimated dollar amount of each subcontract. An EPA Financial Assistance Agreement Recipient must require its prime contractors to complete this form and include it in the bid or proposal package. Prime contractors should also maintain a copy of this form on file.

Prime Contractor Name		Project Name	
Bid/ Proposal No.	Assistance Agreement ID No. (if known)	Point of Contact	
Address			
Telephone No.		Email Address	
Issuing/Funding Entity:			

I have identified potential DBE certified subcontractors	___YES	___NO	
If yes, please complete the table below. If no, please explain:			
<b>Subcontractor Name/ Company Name</b>	<b>Company Address/ Phone/ Email</b>	<b>Est. Dollar Amt.</b>	<b>Currently DBE Certified?</b>
	Continue on back if needed		

<sup>1</sup> A DBE is a Disadvantaged, Minority, or Woman Business Enterprise that has been certified by an entity from which EPA accepts certifications as described in 40 CFR 33.204-33.205 or certified by EPA. EPA accepts certifications from entities that meet or exceed EPA certification standards as described in 40 CFR 33.202.

<sup>2</sup> Subcontractor is defined as a company, firm, joint venture, or individual who enters into an agreement with a contractor to provide services pursuant to an EPA award of financial assistance.

**Disadvantaged Business Enterprise (DBE) Program  
DBE Subcontractor Utilization Form**

I certify under penalty of perjury that the forgoing statements are true and correct. Signing this form does not signify a commitment to utilize the subcontractors above. I am aware of that in the event of a replacement of a subcontractor, I will adhere to the replacement requirements set forth in 40 CFR Part 33 Section 33.302 I.

<b>Prime Contractor Signature</b>	<b>Print Name</b>
<b>Title</b>	<b>Date</b>

**BUILD AMERICA, BUY AMERICA (BABA) ACKNOWLEDGEMENT**

The Contractor acknowledges to and for the benefit of the \_\_\_\_\_ (“Owner”) and the State of Ohio (State) that it understands the goods and services under this Agreement are being funded with federal monies and have statutory requirements commonly known as “Build America, Buy America;” that requires all of the iron and steel, manufactured products, and construction materials used in the project to be produced in the United States (“Build America, Buy America Requirements”) including iron and steel, manufactured products, and construction materials provided by the Contractor pursuant to this Agreement. The Contractor hereby represents and warrants to and for the benefit of the Owner and Funding Authority (a) the Contractor has reviewed and understands the Build America, Buy America Requirements, (b) all of the iron and steel, manufactured products, and construction materials used in the project will be and/or have been produced in the United States in a manner that complies with the Build America, Buy America Requirements, unless a waiver of the requirements is approved, and (c) the Contractor will provide any further verified information, certification or assurance of compliance with this paragraph, or information necessary to support a waiver of the Build America, Buy America Requirements, as may be requested by the Owner or the Funding Authority. Notwithstanding any other provision of this Agreement, any failure to comply with this paragraph by the Contractor shall permit the Owner or Funding Authority to recover as damages against the Contractor any loss, expense, or cost (including without limitation attorney’s fees) incurred by the Owner or Funding Authority resulting from any such failure (including without limitation any impairment or loss of funding, whether in whole or in part, from the Funding Authority or any damages owed to the Funding Authority by the Owner). If the Contractor has no direct contractual privity with the Funding Authority, as a lender or awardee to the Owner for the funding of its project, the Owner and the Contractor agree that the Funding Authority is a third-party beneficiary and neither this paragraph (nor any other provision of this Agreement necessary to give this paragraph force or effect) shall be amended or waived without the prior written consent of the Funding Authority.

\_\_\_\_\_  
Signature

\_\_\_\_\_  
Date

\_\_\_\_\_  
Name and Title of Authorized Signatory, Please Print or Type

\_\_\_\_\_  
Bidder’s Firm



**AMERICAN IRON AND STEEL ACKNOWLEDGEMENT**

The Contractor acknowledges to and for the benefit of the City of \_\_\_\_\_ (“Purchaser”) and the State of Ohio (the “State”) that it understands the goods and services under this Agreement are being funded with monies made available by the Clean Water State Revolving Fund and/or Drinking Water State Revolving Fund that have statutory requirements commonly known as “American Iron and Steel;” that requires all of the iron and steel products used in the project to be produced in the United States (“American Iron and Steel Requirement”) including iron and steel products provided by the Contractor pursuant to this Agreement. The Contractor hereby represents and warrants to and for the benefit of the Purchaser and the State that (a) the Contractor has reviewed and understands the American Iron and Steel Requirement, (b) all of the iron and steel products used in the project will be and/or have been produced in the United States in a manner that complies with the American Iron and Steel Requirement, unless a waiver of the requirement is approved, and (c) the Contractor will provide any further verified information, certification or assurance of compliance with this paragraph, or information necessary to support a waiver of the American Iron and Steel Requirement, as may be requested by the Purchaser or the State. Notwithstanding any other provision of this Agreement, any failure to comply with this paragraph by the Contractor shall permit the Purchaser or State to recover as damages against the Contractor any loss, expense, or cost (including without limitation attorney’s fees) incurred by the Purchaser or State resulting from any such failure (including without limitation any impairment or loss of funding, whether in whole or in part, from the State or any damages owed to the State by the Purchaser). While the Contractor has no direct contractual privity with the State, as a lender to the Purchaser for the funding of its project, the Purchaser and the Contractor agree that the State is a third-party beneficiary and neither this paragraph (nor any other provision of this Agreement necessary to give this paragraph force or effect) shall be amended or waived without the prior written consent of the State.

\_\_\_\_\_  
Signature

\_\_\_\_\_  
Date

\_\_\_\_\_  
Name and Title of Authorized Signatory, Please Print or Type

\_\_\_\_\_  
Bidder’s Firm

Check here if the WPCLF or WSRLA applicant will be requesting an individual waiver for non-American made iron and steel products. Please note that the waiver box does not need to be marked for nationwide waivers.

# **BID FORMS**

The bid forms are not available online. The bid forms are available only by purchasing a set of plans and specifications at the location indicated in the Advertisement for Bids/Public Notice to Bidders.

## SUPPLEMENTARY CONDITIONS

### I. INSURANCE LIMITS:

**LIABILITY, PROPERTY DAMAGE, VEHICLE AND BUILDER'S RISK INSURANCE:** Contractor shall purchase and maintain such comprehensive general liability and other types of insurance as will provide protection from claims as set forth herein which may arise out of or result from Contractor's performance of the work and Contractor's other obligations under all contract documents, whether such performance is by Contractor, by any lower subcontractor, by anyone directly or indirectly employed by any of them, or by anyone for whose acts any of them may be liable.

The claims types for which insurance shall be provided shall include:

- a) Claims under workers compensation, disability benefits and others similar employee benefit acts;
- b) Claims for damage because of bodily injury, occupational sickness, sickness, disease, or death of any person;
- c) Claims for damages sustained by any person as a result of an employment practices offense directly or indirectly related to the employment of such person by the contractor or a subcontractor or by any other person for any other reason;
- d) Claims for damages, other than to the work itself, because of injury to or destruction of tangible property, including loss of the use resulting therefrom;
- e) Claims for damages because of bodily injury or death of any person or for property damage arising out of the ownership, leasing, renting, hires, loaned, or otherwise using, and the maintenance of any item of construction or equipment of any power tools by Contractor or a subcontractor;
- f) Claims for damages because of bodily injury or death of any person or for property damage arising out of the ownership, leasing renting or using maintenance of any motor vehicle, by Contractor or a subcontractor;
- g) Claims for damages to the work itself, and/or all existing City property located in the proximate area of the work, because of injury or destruction of the tangible property, including the loss of use resulting therefrom; and
- h) Claims for damages because of bodily injury or death of any person or property damage arising out of the use, transportation or storage of any type of explosives, explosive devices or dangerous ordnance use in doing work included in the Contract.

The insurance limits required by this section shall include the specific coverage as are applicable to the work, and shall be written for the specified limits stated herein, or for the specific limits as provided in any applicable supplementary specification, or as may be required by law, wherever is greater.

The Contractor shall have and maintain the type of insurance that provides the limits of coverage for each occurrence. If the Contractor's policy is not of the form providing coverage limits for each occurrence, then he shall obtain a rider providing coverage by occurrence for the work under this specification.

The insurance shall be written by a solvent and otherwise acceptable company(s) authorized to do business in the State of Ohio,

Evidence of insurance shall be provided by the Contractor to the City for review and acceptance by the City, before the issuance of the Notice to Commence.

Such evidence shall consist of the Contractors insurance agents "insurance affidavit" (when requested, on a form that is on file at the City Engineer's office) the Certificate of Insurance plus the Certificate of Compliance provided by the Ohio Department of Insurance for the Company(s) in question.

Failure to provide evidence of the maintenance of all of the required insurance shall suspend the City's obligation to pay for any and all work performed after the cessation of the required coverage for which evidence has previously been provided, and can be the basis of a non-compensable order to suspend work or for the termination of the contract for cause.

The Contractor's policy shall provide and the Certificate of Insurance shall reflect the fact that the City is an additional insured and all (if any) other additional insured shall receive at least thirty (30) days notice of any cancellation, change reducing the coverage, or refusal to renew, which is adverse to the interests of the City and/or other additional insured to be effected. The City and other additional insured shall be provided with any notice on non-renewal, regardless of the cause.

LEAD SERVICE LINE REPLACEMENTS

The liability limits for the required coverage notes above shall be at least:

	<b>EACH OCCURRENCE</b>	<b>AGGREGATE</b>
Bodily Injury & Property Damage Combined	\$ 2,000,000.00	\$ 2,000,000.00
Vehicle Liability	\$ 1,000,000.00	\$ 1,000,000.00
Builders Risk/Installation Floater (if applicable, in the sole discretion of the City)	(The amount of the contract)	

**ANY AND ALL LIABILITY LIMITS SHALL BE EXCLUSIVE OF DEFENSE COSTS.**

**II. CONTROLLING LAW AND JURISDICTION:**

This Agreement shall in all respects be interpreted and construed in accordance with and governed by the laws of the State of Ohio. This Agreement shall be subject to the jurisdiction of the Court of Common Pleas Lorain County, Ohio.

**III. ENGINEER:**

Unless otherwise provided, the Engineer shall be CT Consultants, Inc. All questions during bidding should be addressed to Bob McNutt, who can be reached at CT Consultants, Inc., at 330-697-0437.

**IV. ENDANGERED AND CANDIDATE SPECIES:**

Any trees that appear to be potential summer habitat areas for the federally-listed endangered Indiana bat (*Myotis Sodalis*) shall not be cut down between April 1 and September 3. Trees that are not considered to be potential summer habit for the Indiana bat can be cut down at any time. Removal or trimming of trees and saplings shall only be considered when required to complete construction activities. Potential summer habitat requirements for the Indiana bat are as follows:

- Dead or live trees and snags with peeling or exfoliating bark, split tree trunk and/or branches, or cavities, which may be used as maternity roost areas.
- Live trees which have exfoliating bark

This project is also within the range of the piping plover and eastern massasauga which are federally-listed endangered and candidate species, and the bald eagle which is protected under the Bald and Golden Eagle Protection Act and the Migratory Bird Treaty Act. If any of these species are identified or suspected on the project site, the contractor shall cease all activities and contact the Engineer immediately.

**V. CONTINGENCY, IF ANY:**

Any Extra Work performed or Extra Materials utilized under the Contingency, if a part of the bid, shall be approved in writing by the Engineer, and only the Engineer, prior to commencement of that activity and prior to payment for that activity. Final costs for the Extra Work incurred shall be approved by the Engineer. Approval of this activity shall be directly related to and necessary for the completion of the Scope of Work associated with the construction project. Any unused portion of the contingency shall be returned to the City of Elyria by final change order.

## EQUAL EMPLOYMENT OPPORTUNITY CLAUSE

**During the performance of this contract, the contractor agrees as follows:**

1. The contractor shall not discriminate against any employee or applicant for employment because of race, religion, age, color, sex, national origin or handicap. The contractor shall take affirmative action to insure that applicants are employed and that employees are treated without regard to race, religion, color, sex, national origin or handicap during employment.

As used herein, the work "treated" shall mean and include without limitation, the following:

**recruited:** whether in the form of rates of pay or other forms of compensation

**selected for training:** including apprenticeship, promoted, upgraded, transferred, laid off and terminated

The contractor agrees to and shall post in conspicuous places available to employees and applicants for employment, notices to be provided by the contracting officers setting forth the provisions of the non-discrimination clause.

2. The contractor shall, in all solicitations or advertisement for employees placed by or on the behalf of the contractor, state that all qualified applicants will receive consideration for employment without regard to race, religion, color, sex, national origin or handicap.
3. The contractor shall submit to the City, in writing, an affirmative action plan and shall furnish all information and reports required by the City or its representatives pursuant to this chapter and permit access to the contractor's books, records, and accounts by the contracting agency and affirmative action officials for purposes of investigation to ascertain compliance with the Affirmative Action Program. The contractor may comply with the provisions of this section by doing one of the following:
  - (a) The contractor may submit its Affirmative Action Program in writing at the time of its submission of bid; or
  - (b) The contractor may submit its Affirmative Action Program in writing prior to its submission of bid for pre-certification.

The contractor's Affirmative Action Program may be pre-certified upon the filing and approval of its Affirmative Action Program with the City's OEO office not more than six months prior to its bid submission. Upon pre-certification, the contractor will be issued a pre-certification compliance number for its Affirmative Action Program, which may be used and referred to in any bid submission in the place of any other written requirement for Affirmative Action Program submission. It shall be the sole responsibility of the contractor to be re-certified upon the expiration of its pre-certification. Approved programs may be reviewed before any pre-certification expiration date.

4. The contractor shall send to each labor union or representatives of workers with which he/she has a collective bargaining agreement or other contract or understanding, a notice advising the labor union or workers' representative of the contractor's commitments under the Equal Employment

LEAD SERVICE LINE REPLACEMENTS

Opportunity Clause of the City of Elyria and shall post copies of the notice in conspicuous places available to employees and applicants for employment.

5. The contractor shall take such action with respect to any subcontractor as the City of Elyria may direct as a means of enforcing the provisions of the EEO Clause including penalties and sanctions for noncompliance. Provided, however; that in the event the contractor becomes involved in or is threatened with litigation as a result of such direction by the City, the City will enter into such litigation as is necessary to protect the interests of the City and to effectuate the City's Equal Opportunity Program and in the case of contracts receiving federal assistance, the contractor or the City may request the United States to enter into such litigation to protect the interests of the United States.
6. The contractor shall file and shall cause his/her subcontractors, if any, to file compliance reports with the City in the form and to the extent prescribed by the City or its representative. Compliance reports shall contain information as to the employment practices, policies, programs and statistics of the contract and subcontractor(s).
7. The contractor shall include the provisions of the Equal Employment Opportunity Clause in every subcontract or purchase order so that such provisions will be binding upon each subcontractor and/or vendor.
8. Refusal by the contractor or subcontractor to comply with any provision of this program as herein stated and described will subject the offending party to any or all of the following penalties:
  - (a) Withholding of all future payments under the involved public contracts to the contractor in violation until it is determined that the contractor or subcontractor is in compliance with the provision of this contract.
  - (b) Refusal of all future bids for any public contract with the City or any of its departments or divisions until such time as the contractor or subcontractor demonstrates that he/she has established and shall carry out the policies of the programs as herein outlined.
  - (c) Cancellation of the public contract and declaration of forfeiture of the performance bond.
  - (d) In cases in which there is substantial or material violation or the threat of substantial or material violation of the compliance procedure or as may be provided by contract, appropriate proceedings may be brought to enforce these provisions, including the enjoining within applicable laws of contractors, subcontractors or other organizations, individuals, or groups who prevent directly or indirectly or seek to prevent directly or indirectly compliance with the policy as herein outlined.

\_\_\_\_\_  
Name of Company Official

\_\_\_\_\_  
Title

\_\_\_\_\_  
Name of Company

\_\_\_\_\_  
Area Code/Telephone Number

\_\_\_\_\_  
Signature of Company Official

\_\_\_\_\_  
Date Signed

# CONTRACTOR'S/VENDOR'S AFFIRMATIVE ACTION INFORMATION SHEET

This Affirmative Action Information Sheet is to be completed and returned with the Bid.

Bidder's EEO Officer's Name: \_\_\_\_\_

Bidder's EEO Officer's Title: \_\_\_\_\_

Bidder's Firm Name: \_\_\_\_\_

Address: \_\_\_\_\_

City/State/Zip Code \_\_\_\_\_

Telephone Number: (\_\_\_\_\_) \_\_\_\_\_ - \_\_\_\_\_ Fax Number: (\_\_\_\_\_) \_\_\_\_\_ - \_\_\_\_\_

Note: The bidder must comply with either #1 or #2 below. (Place a check mark in the correct item.)

#1 \_\_\_\_\_ Our firm has been pre-certified, by Elyria's EEO Officer.

Our pre-certification number is: \_\_\_\_\_

Our pre-certification expires on: \_\_\_\_\_

\_\_\_\_\_ A copy of our pre-certification letter from Elyria is attached.

#2 \_\_\_\_\_ We are enclosing our own Affirmative Action Plan (number of page(s) \_\_\_) with this bid.

\*\*\*\*\*

**(For City Office Use Only)**

**CITY OF ELYRIA SIGN-OFF:**

Affirmative Action/Equal Opportunity Officer: \_\_\_\_\_

Comments:

\_\_\_\_\_

**CONTRACTOR/SUPPLIER AFFIRMATIVE ACTION PROGRAM**

**TABLE 1**

TOTAL PRESENT WORKFORCE BREAKDOWN

JOB CATAGORY	TOTAL MALES	MALE EMPLOYEES MINORITY GROUPS				TOTAL FEMALES	FEMALE EMPLOYEES MINORITY GROUPS				TOTAL ALL EMPLOYEES	
		WHITE	BLACK	SPANISH	OTHER MINORITY		WHITE	BLACK	SPANISH	OTHER MINORITY		
OFFICIALS/ ADMINISTRATORS												
PROFESSIONALS												
TECHNICIANS												
PROTECTIVE SERVICE												
SALES												
PARAPROFESSIONALS												
OFFICE-CLERICAL												
SKILLED CRAFT SPECIFY												
JOURNEYMEN												
HELPERS												
APPRENTICES												
TRAINEES												
LABORERS												
SERVICE/CUSTODIAL												
OTHERS (SPECIFY)												
<b>TOTALS</b>												



## PRICES TO INCLUDE

### PART 1 - GENERAL

Any work shown on the plans or required in the specifications but not paid for separately as a bid item shall be included in the cost of other bid items. The amount bid for each Bid Item shall include the following:

- 1.1 All labor, materials, tools, equipment, and transportation necessary for the proper execution of the work in accordance with the Contract Documents.
- 1.2 All assistance required by the Engineer to verify compliance with the Contract Documents, including measuring for final pay quantities.
- 1.3 Project coordination and scheduling.
- 1.4 Detailed breakdown of lump sum bid items as requested by the Engineer.
- 1.5 All provisions necessary to protect workmen, the general public, and property along the work in accordance with the Contract Documents.
- 1.6 Record drawings of the installed location of all underground utility lines, etc.
- 1.7 All specified testing.
- 1.8 Reimbursement to Owner for costs of re-inspection or re-testing of any work not installed in compliance with the Contract Documents.
- 1.9 Construction staking of the improvements.
- 1.10 All erosion control measures in accordance with the Contract Documents.
- 1.11 Surface restoration.

### PART 2 - ITEMS

All work proposed by this contract shall be quantified and paid for in accordance with the pertinent O.D.O.T. specification except as specifically altered by other provisions of this contract.

#### 2.1 PRECONSTRUCTION VIDEOTAPE DOCUMENTATION

##### Basis of Payment

The lump sum price shall include all costs associated with hiring a professional videotaping firm to document in detail the existing conditions of the entire work area and potential disturbed areas and submitting a high quality video file on USB with audio commentary and video log.

## 2.2 BONDS AND INSURANCES, AS PER PLAN

### Basis of Payment

A "Bonds and Insurances" item (including "Owner/Contractor Protective Policy," "All Risk Builder's Risk Insurance," and/or "Installation Floater Insurance," and all other insurance as required) has been included in the bid proposal.

## 2.3 EXPLORATORY EXCAVATION, AS PER PLAN

### Method of Measurement

The method of measurement shall be paid by the number of each service address requiring advanced exploratory excavations to determine existing service line materials.

### Basis of Payment

The basis of payment shall be as per ODOT Item 638 with the following additions; the unit price shall also include exploratory excavation (by hydraulic excavator and/or hydro-vac potholing), field location, and backfilling as specified; excavating and uncovering to determine water service material and depth in order to identify and replace lead service lines; furnishing and placement and testing of backfilling, support protection, relocation and/or replacement of all existing utilities (sanitary force mains, storm and sanitary sewers, culverts, gas lines, curb drains, catch basins, underground conduit, wires, cables, utility poles, signs, etc.); furnishing and replacement of existing curb boxes and stainless steel rods for each service pot-holed; installing and maintaining restoration including temporary or permanent traffic surface in paved areas, top soil, finish grading, seed, and all else necessary to restore the area to existing conditions or better; maintenance, removal and replacement of all signs, mailboxes, paper boxes, fences, guardrails, or other structures; and the furnishing of all labor, materials, tools and appurtenances necessary to complete the work as specified or as shown.

Excavation at each address included in the Schedule will include both the public side and the private side services, include providing report of findings to OWNER and meeting with OWNER to determine final addresses that will have water service line replaced, either public, private or both sides of the service. Final replacement of services, including final restoration (not counting the initial restoration of the pot-holing) will be paid for under other bid schedule items.

- 2.4 TYPE "A" PAVEMENT REPLACEMENT (CONCRETE), ROADWAY, AS PER PLAN
- 2.5 TYPE "A" PAVEMENT REPLACEMENT (CONCRETE), DRIVEWAY, APRON, OR PARKING LOT, AS PER PLAN
- 2.6 TYPE "A" PAVEMENT REPLACEMENT (CONCRETE), DRIVEWAY, APRON, OR PARKING LOT, COMMERCIAL, AS PER PLAN
- 2.7 TYPE "B" PAVEMENT REPLACEMENT (ASPHALT OVER CONCRETE), ROADWAY, AS PER PLAN
- 2.8 TYPE "C" PAVEMENT REPLACEMENT (ASPHALT), ROADWAY, AS PER PLAN
- 2.9 TYPE "C" PAVEMENT REPLACEMENT (ASPHALT), DRIVEWAY, APRON, OR PARKING LOT, AS PER PLAN

### Method of Measurement

The method of measurement shall be as per ODOT 253 or 255 as applicable.

### Basis of Payment

The basis of payment shall be as per ODOT 253 or 255 as applicable with the following additions:

The unit price shall also include saw cutting; removal and replacement of any affected curbing; furnishing, installation, maintenance, removal, and disposal of temporary road materials or temporary pavement courses; preparation for permanent pavement courses; and any additional expenses for cold weather protection.

- 2.10 6 INCH DIAMETER & SMALLER SEWER & DRAIN REPLACEMENT, CONTINGENCY
- 2.11 8 INCH THRU 12-INCH DIAMETER SEWER & DRAIN REPLACEMENT, CONTINGENCY

### Method of Measurement

The quantity to be paid shall be the number of linear feet directed to be installed by the Engineer.

### Basis of Payment

The unit price shall be irrespective of the depth of pipe and if not called out as a separate pay item shall include the furnishing and laying of pipe; field location, exploratory excavation, and verification of existing utilities prior to laying conduit; excavation; sheeting; shoring; disposal of undesirable and excess material; all pumping required for adequate handling of flow bypassing, underground water and/or surface water; bedding; compacted backfill material; Owner's costs related to re-inspection or re-testing of failed or re-compacted backfill material; specials; bends; tees; fittings; plugs; stoppers; cleanouts; bulkheads; jointing material; protection of existing trees or vegetation to be saved; protection and/or replacement of all existing utilities; connection to existing conduit or structures; removal and replacement of poles, posts, signs, mailboxes, paper boxes, fences, landscape timbers, guardrails, sign wiring, fixtures, or other appurtenances; surface grading; temporary pavement; and the furnishing of all labor, materials, tools and appurtenances necessary to complete the work as specified or as shown.

- 2.12 CONDUIT, MISC.: ROCK EXCAVATION, CONTINGENCY

### Method of Measurement

The quantity to be paid shall be the number of cubic yards directed to be removed. Rock shall be as defined in Specification Section 310000 Paragraph 1.3.K.

### Basis of Payment

The unit price shall include all labor and equipment to remove rock in the pipe trench or pipe structure excavation and disposed or incorporated into the work.

## 2.13 MAINTAINING TRAFFIC, AS PER PLAN

### Basis of Payment

Payment shall be made progressively throughout the contract period in proportion to the percentage of work complete or as otherwise approved by the Engineer.

## 2.14 COPPER SERVICE BRANCH, AS PER PLAN

### Method of Measurement

The method of measurement shall be as per ODOT 638 except that the water service connections shall be paid per each as short service connections or long service connections for the diameter designated in the Bid Schedule, on the plans or directed by the Engineer regardless of length of the connection. Short service connections shall be those which the water main is on the same side of centerline of the pavement as the lot serviced. Long service connections shall be those which the water main is on the opposite side of centerline of the pavement as the lot serviced.

### Basis of Payment

The basis of payment shall be as per ODOT 638 with the following exceptions: The unit price shall also include connection to the existing service at locations designated on the plans; exploratory and other excavation and field location of existing service connections, new curb stops and boxes, corporation stops, copper services, all fittings and adapters necessary to connect to new or existing meters, blocking, backfill, bedding, all restoration and the furnishing of all labor, materials, tools and appurtenances necessary to complete the work as specified or as shown.

**Note: The Contractor shall bore or push service connections across the roadway. Drive aprons and sidewalks shall be protected and avoided during connection work unless the shut-off is located in the apron or sidewalk. If shut-off is located in the apron or sidewalk, the contractor will be paid under the contract unit price bid for the various apron and sidewalk line items. It may be necessary to bore under existing utilities if sufficient depth of cover cannot be otherwise maintained.**

## 2.15 PRIVATE LEAD SERVICE (OR GALVANIZED FOLLOWING CITY LSL) LINE REPLACEMENT (50' OR LESS)

### Method of Measurement

The method of measurement shall be as per ODOT 638 except that the water service connections shall be paid per each as for the diameters designated in the Schedule in Section 331113.02 or as directed by the Engineer for up to 50 LF of length of the connection.

### Basis of Payment

The basis of payment shall be as per ODOT 638 with the following exceptions: The unit price shall also include all coordination with water service customer, connection to the existing service at locations designated on the plans and terminating inside the building with a new, appropriately sized ball valve; exploratory excavation and field location of existing service connections (if no separate payment included in the Bid Schedule), copper services, all fittings and adapters necessary to connect to new or existing meters, blocking, restoration and the furnishing of all labor, materials, tools and appurtenances necessary to complete the work as specified or as shown.

**Note: The Contractor shall replace lead service lines on private property by trenchless methods whenever possible to avoid disruption of private property and minimize restoration. Where trenchless is deemed not feasible the Contractor shall review with UTILITY and gain approval for trenching on private property. Driveways and sidewalks shall be protected and avoided during connection work unless the shut-off is located in the apron or sidewalk. If shut-off is located in the apron or sidewalk, the contractor will be paid under the contract unit price bid for the various apron and sidewalk line items. It may be necessary to bore under existing utilities if sufficient depth of cover cannot be otherwise maintained.**

## 2.15 PRIVATE LEAD SERVICE (OR GALVANIZED FOLLOWING CITY LSL) LINE REPLACEMENT (BEYOND 50')

### Method of Measurement

The method of measurement shall be as per ODOT 638 for the diameters designated in the Schedule in Section 331113.02 or as directed by the Engineer.

### Basis of Payment

The basis of payment shall be as per ODOT 638 with the following exceptions: The unit price shall also include connection to the existing service at locations designated on the plans; exploratory excavation and field location of existing service connections (if no separate payment included in the Bid Schedule); disposal of undesirable and excess materials; copper services, all fittings and adapters necessary to connect to new or existing meters; blocking; restoration and the furnishing of all labor, materials, tools and appurtenances necessary to complete the work as specified or as shown. The length of additional service line replacement to be paid for under this item shall be for the actual length of service line that exceeds 50 LF as included in Prices to Include Item 2.13 above. All other fittings, valves, appurtenances, etc. needed above shall be included under Prices to Include Item 2.13 above.

2.16 PRIVATE LEAD SERVICE (OR GALVANIZED FOLLOWING CITY LSL) LINE REPLACEMENT, RIGID COPPER PIPE, FOR INTERIOR CONNECTION

Method of Measurement

The quantity to be paid shall be the number of feet installed per the plans and specifications measured along the centerline of the pipe from each end of the pipe replacement and/or additional pipe installed as directed by the Engineer.

Basis of Payment

The unit price shall include connection to the existing service within the internal wall of the structure as designated by the plans; rigid pipe fittings as needed, disposal of undesirable and excess materials, restoration and the furnishing of all labor, materials, and tools necessary to complete the work as specified or as shown.

2.17 4 INCH WATER MAIN, AS PER PLAN

Method of Measurement

The method of measurement shall be as per ODOT 638.

Basis of Payment

The basis of payment shall be as per ODOT 638 with the following additions: The unit price shall be irrespective of the depth of pipe and shall include excavation, bedding, backfill, compaction, all waterline testing, chlorination/disinfection, flushing, supports, thrust blocking, joint restraints, polyethylene encasement, tees, bends, reducers, plugs, caps, and all other necessary fittings.

## **PROJECT SPECIFIC REQUIREMENTS**

### **1 - CONTACT DURING BIDDING**

- 1.1 All questions during bidding should be addressed to Bob McNutt, who can be reached at CT Consultants, Inc., at 330.697.0437.

### **2 - PERIODIC PAYMENTS**

- 2.1 This project is expected to be funded in whole or in part by the Ohio EPA WSRLA Program. The Contractor shall comply with all requirements of this program. The periodic payments to the Contractor may be made in whole or in part through the OWDA. In paragraph 14.02 C.1. of the General Conditions, change "ten days" to "sixty days."
- 2.2 Ohio EPA must approve all change orders prior to a change order item being paid on a pay estimate.

### **3 - INSURANCE**

- 3.1 Section SC-5.04(D) of the Supplementary Conditions shall be deleted and no "all risk builders risk" or "installation floater" insurance need be purchased by the Contractor.

### **4 - WORKING HOURS**

- 4.1 No work shall be performed between the hours of 7:30 PM and 7:30 AM nor on Saturday, Sunday, or legal Holidays, without written permission of the Owner.

### **5 - PROJECT COMPLETION**

- 5.1 All work including restoration and clean-up shall be completed no later than the contract completion date. Failure to complete all work within the allotted time will result in assessment of liquidated damages. Upon completion of all work and written notification of same by the Contractor, the Engineer and Owner will compile a punch list. The punch list will be sent to the Contractor. All punch list work shall be completed to the satisfaction of the Engineer and the Owner within 14 days after receipt of the punch list. Failure to complete the punch list work within the allotted time will result in assessment of liquidated damages.

### **6 - DRUG-FREE WORKPLACE PROGRAM**

- 6.1 In accordance with Ohio Revised Code §153.03 and during the life of this project, the Contractor and all its Subcontractors that provide labor on the Project site must be enrolled in and remain in good standing in the Ohio Bureau of Worker's Compensation ("OBWC") Drug-Free Workplace Program ("DFWP") or a comparable program approved by the OBWC.

## 7 - OHIO ETHICS LAW

- 7.1 Contractor agrees that it is currently in compliance and will continue to adhere to the requirements of Ohio Ethics law as provided by Section 102.03 and 102.04 of the Ohio Revised Code.



## **STANDARD SPECIFICATIONS**

1. The "Construction and Material Specifications" of the State of Ohio Department of Transportation (ODOT), 2023 edition, current ODOT supplemental specifications, and current ODOT standard drawings shall govern work and materials which are not specified or modified herein or on the project Contract Drawings. All references to "the Department" shall be changed to "the Owner or his Representative." The project Contract Drawings and Specifications, in the event of a discrepancy, shall supersede the ODOT Specifications.

The absence of an "As Per Plan" designation on some item descriptions in the proposal for which there are clear and controlling plan notes, specifications, or other requirements does not relieve the Contractor of the responsibility to read, bid and construct those particular items in accordance with the governing plan notes, specifications, or other requirements and the Contractor shall have no basis of claim based upon an "order of precedence".

ODOT 104.02 D., 611.04, 611.12, and 611.13 shall not apply to this project.

## SECTION 011100 - SUMMARY OF WORK

### PART 1 - GENERAL

#### 1.1 LOCATION OF THE PROJECT

- A. The project is located within the water service area of the City of Elyria Water Utility. Specific location or addresses will be included in the Schedule at the end of 331113.02 – Lead Service Line Replacements.

#### 1.2 PROJECT DESCRIPTION

- A. The project consists of replacing lead service lines on either or both the public or private side of the right of way for addresses as noted. All explorations, excavation, completion of work, backfilling, restoration and final acceptance is included.
- B. The Bid Documents contain Bid Forms for a Base Bid and three (3) Alternates.

**The bidder must bid all Alternates.**

#### 1.3 SPECIFICATIONS

- A. In general, these Specifications describe the work to be performed by the various trades, other than work specifically excluded. It shall be the responsibility of the Contractor and Subcontractors to perform all work incidental to their trade, whether or not specific mention is made of each item, unless such incidentals are included under another Item.
- B. It is advised that the Contractor and all Subcontractors familiarize themselves with the contents of the complete Specifications, particularly for the trades preceding, following, related or adjacent to their work.

#### 1.4 STANDARD DETAILS

- A. OWNER standard details for pavement, trenches, water services, meter replacements, and related details for this work shall be used. OWNER details included at the end of this Section are shown below, with clarifying notations. Where OWNER does not have standard details, ODOT details shall be used.
  1. Water Service Tie In for Inside Meters (SD-4-8): The minimum service shall be 1” diameter. The detailed specifications Section 331113.02 shall govern instead of the call out for materials on this detail.
  2. Type A Pavement Replacement - Concrete (SD-5-1)
  3. Type C Pavement Replacement – Asphalt (SD-5-3)
  4. Trenching, Embedment and Backfill Detail (SD-1-1): Final Backfill for Types B and C, and Special Backfill Material as shown in the details shall be #304 limestone, or may be substituted with Low Strength Mortar backfill per Specification Section 310000. NOTE #5 specification section callout is changed to Specification Section 310000.
  5. Type A Walk Replacement (SD-5-7)

6. Expansion Joint (SD-5-9)
7. Curb Replacement Detail (SD-5-16)
8. Curb Ramp Details

1.5 City Permits and Inspections

- A. City Building Department will be part of the inspection group; therefore, no building department permit is required.
- B. Licensed plumbers are not required to perform this work.

END OF SECTION 011100

## SECTION 011419 – USE OF SITE

### PART 1 - GENERAL

#### 1.1 GENERAL

- A. The Contractor will be allowed the use of as much of the site designated for the improvements as is necessary for his operation.

#### 1.2 USE OF STREETS

- A. During the progress of the work, the Contractor shall make ample provisions for both vehicle and pedestrian traffic on any public street and shall indemnify and save harmless the Owner from any expense whatsoever due to their operations over said streets. The Contractor shall also provide free access to all the fire hydrants, water, and gas valves located along the line of his work. Gutters and waterways must be kept open or other provisions made for the removal of storm water. Street intersections may be blocked only one-half at a time, and the Contractor shall lay and maintain temporary driveways, bridges and crossings, such as in the opinion of the Engineer are necessary to reasonably accommodate the public.
- B. In the event of the Contractor's failure to comply with these provisions, the Owner may cause the same to be done, and may deduct the cost of such work from any monies due the Contractor under this Agreement, but the performance of such work by the Owner at its instance shall serve in no way to release the Contractor from his general or particular liability for the safety of the public or the work.
- C. The Contractor shall repair at no cost to the Owner, all existing roads, parking areas, grassed areas that are damaged due to the execution of his work. The Contractor shall remove daily all mud, soil and debris that may be tracked onto existing streets, drives, or walks by his equipment or that of subcontractors or suppliers.

#### 1.3 CLOSING STREETS TO TRAFFIC

The Contractor may with the approval of the Engineer, close streets, or parts of streets, to vehicular traffic. The streets are to remain closed as long as the construction work or the condition of the finished work requires or as determined by the Engineer. The Engineer shall be the judge of how many streets or parts of streets it is necessary for the Contractor to close at any time, and may refuse to permit the closing of additional streets to traffic until the majority of the work on the closed streets is completed and they are opened to traffic.

#### 1.4 RIGHTS-OF-WAY

- A. Whenever it is required to perform work within the limits of public or private property or in rights-of-way, such work shall be done in conformity with all agreements between the Owner and the owners of such. Care shall be taken to avoid injury to the premises entered, which premises shall be left in a neat and orderly condition by the removal of rubbish and the grading of surplus materials, and the restoration of said public or private property to the same general conditions as pertained at the time of entry for work to be performed under this contract.
- B. The Contractor shall not (except after consent from the proper parties) enter or occupy with men, tools or equipment, any land outside the rights-of-way or property of the Owner.
- C. When the Contractor performs construction within 10 ft. of a right-of-way or easement line, he shall place tall stakes properly identified at points of change in width or direction of the right-of-way or easement line and at points along the line so that at least two stakes can be seen distinctly from any point on the line.

#### 1.5 EASEMENTS

- A. Where the work is to be constructed upon easements, such easements will be secured by the Owner without cost to the Contractor. The Contractor shall not enter upon or occupy any private property outside of the limits of the easements or approved Agreement for Work on Private Property furnished.
- B. Care shall be taken to avoid injury to the premises entered, which premises shall be left in a neat and orderly condition by the removal of rubbish and the grading of surplus materials, and the restoration of said public or private property to the same general conditions as pertained at the time of entry for work to be performed under this contract.

#### 1.6 PROTECTING EXISTING BUILDINGS, STRUCTURES AND ROADWAYS

- A. The Contractor shall, at his own expense, shore up and protect any buildings, roadways, utilities or other public or private structures which may be encountered or endangered in the prosecution of the work, and that may not be otherwise provided for, and he shall repair and make good any damages caused to any such property by reason of his operations. All existing fences removed due to the prosecution of the work shall be replaced by the Contractor. No extra payment will be made for said work or material, but the cost of this work must be included in the price stipulated for the work to be done under this contract.

#### 1.7 SITE FACILITIES

- A. The Contractor shall furnish and place sufficient quantities of portable toilet facilities at locations convenient for use by the Contractor's personnel, Subcontractors, the Engineer, and the Owner.

#### 1.8 RESTORATION

- A. The contractor shall restore all areas per the plans and specifications and if not specified, at least to the condition existing prior to the start of work.

END OF SECTION 011419

## SECTION 011423 - ADDITIONAL WORK, OVERTIME

### PART 1 - GENERAL

#### 1.1 NIGHT, SUNDAY AND HOLIDAY WORK

- A. No work will be permitted at night, Sunday or legal holidays except as noted on the plans or in the case of emergency and then only upon written authorization of the Engineer. Where no emergency exists, but the Contractor feels it advantageous to work at night, Sunday or legal holidays, the Contractor shall notify the Engineer at least two (2) days in advance, requesting written permission. Any work performed during the absence of the Engineer will be done at the Contractor's risk and responsibility and may be subject to rejection upon later inspection.

END OF SECTION 011423

## SECTION 012513 – PRODUCT SUBSTITUTION PROCEDURES

### PART 1 - GENERAL

#### 1.1 MATERIALS AND EQUIPMENT

- A. In the specifications and on the Engineer's drawings, are specified and shown certain pieces of equipment and materials deemed most suitable for the service anticipated. This is not done to eliminate other equipment and materials equally as good and efficient. The Contractor shall prepare his bid on the particular materials and equipment specified. Following the award of the contract, should the Contractor desire to use other equipment and materials, he shall submit to the Owner a written request for such change and state the advantage to the Owner and the savings or additional cost involved by the proposed substitution. The determination as to whether or not such change will be permitted rests with the Owner and the Engineer.
- B. Each major item of equipment shall be inspected by a manufacturer's representative during installation and upon completion of the work. The Contractor shall supply the Engineer with a certificate of such inspection.

END OF SECTION 012513



## SECTION 013119 - PROJECT MEETINGS

### PART 1 - GENERAL

#### 1.1 PRECONSTRUCTION MEETING

- A. Prior to the Contractor beginning any work on the project, the Owner will schedule and hold a preconstruction meeting to discuss all aspects of the contract work.
- B. The Contractor shall be present and be prepared to comment in detail on all aspects of his work.
- C. The Contractor shall bring to the preconstruction meeting a proposed construction progress schedule, erosion control plan, quality control program, concrete mix designs, asphalt mix designs (JMF), etc. Approval of each by the Engineer is required prior to the start of any work.
- D. Included in the construction progress schedule shall be an implementation sequence of the proposed erosion control efforts required by the contract.

#### 1.2 PROGRESS MEETINGS

- A. Monthly progress meetings will be held at a location to be determined by the Owner on a regularly scheduled day mutually convenient to the Owner, Contractor, and Engineer.
- B. The Contractor shall provide an updated construction progress schedule and be prepared to comment in detail on all aspects of his work.

END OF SECTION 013119

## SECTION 013216 – CONSTRUCTION PROGRESS SCHEDULE

### PART 1 - GENERAL

#### 1.1 PROGRESS SCHEDULE

- A. Immediately after signing the Contract, the General Construction Contractor shall prepare a graphic progress schedule, indicating the work to be executed during each month and the rate of expected progress to secure completion on the agreed-upon completion date. The progress schedule shall be approved by the Engineer and Owner prior to starting work on the site. Copies of such graphic progress charts, upon which has been indicated the actual progress, shall be furnished to the Engineer with each requisition for payment.

This progress schedule must follow these general time frames (may vary with project):

1. Chip seal, paving fabric and/or the leveling course must start within 7 calendar days from the date of milling.
  2. Casting adjustments and/or curb replacements must start within 7 calendar days from the completion of the chip seal, intermediate course and/or fabric.
  3. Surface course asphalt concrete must begin installation within 7 calendar days from the completion of the casting adjustments and/or curb replacement.
  4. Traffic paint, temporary or permanent must be installed within a time period as deemed adequate and desirable for each location.
- B. Should the rate of progress fall materially behind the scheduled rate of progress, and unless the delay is authorized by the Engineer, each offending Contractor shall furnish additional labor, work overtime, or take other necessary means required for completion of the work on the scheduled date. No additional compensation beyond the set Contract price shall be paid for action taken or overtime expense incurred in maintaining scheduled progress.

END OF SECTION 013216

## SECTION 013236 – VIDEO MONITORING AND DOCUMENTATION

### PART 1 - GENERAL

#### 1.1 SCOPE

- A. Provide all labor, materials, equipment, and services, and perform all operations necessary to furnish to the Owner a complete color audio-video record of the surface features within the proposed construction zone of influence on USB. This record shall include, but not be limited to, all audio-video files, storage cases, video logs, and indexes. The purpose of this coverage shall be to accurately document the pre-construction condition of these surface features.

#### 1.2 QUALIFICATIONS

- A. The video file documentation shall be done by a responsible commercial firm known to be skilled and regularly engaged in the business of pre-construction color audio-video documentation. The firm shall furnish such information as the Owner deems necessary to determine the ability of that firm to perform the work in accordance with the Contract specifications.

#### 1.3 PRODUCTS

- A. The color audio-video recording delivered to the Owner shall be on a high quality digital format on USB.

END OF SECTION 013236

SECTION 013319.01 - FIELD TEST REPORTING  
- AGGREGATE, SOILS, CONCRETE AND ASPHALT

PART 1 - GENERAL

1.1 SUMMARY

- A. The Contractor shall be responsible for the quality of all materials incorporated into the project work and shall be responsible for all costs of testing and certification of same. The Contractor shall provide the City Engineer a list of three (3) local qualified firms for the City to select from to be the Contractor's testing firm.
- B. The Contractor shall provide the engineer with a Quality Control Plan in which his testing methods/procedures are defined. Said Plan shall meet with the approval of the Engineer and include identification of laboratories, types of testing, and the tentative amount and scheduling of each.

All certification of tests and/or gradations for material to be utilized in the work and all quality control testing shall be performed by an independent laboratory (not affiliated with, owned by, or managed by the Contractor). The laboratory shall be accredited by the AASHTO Materials Reference Laboratory for the type of testing performed.

- C. The Owner may perform field Quality Assurance testing; however, such testing shall not relieve the Contractor from the responsibility of Quality Control testing or from supplying certificates from manufacturers or suppliers to demonstrate compliance with the specifications. It is intended that the testing by the Contractor and the Owner be complimentary toward a quality project; however, the Contractor may not assume the Owner will test or that any tests will be done in lieu of the Contractor's own Quality Control testing. In the same sense, the Contractor may not rely on Owner Quality Assurance testing as a basis of acceptance or approval of his work nor may any Owner-performed testing be reflected in his submitted plan.

1.2 TEST CRITERIA

- A. The following tests at a minimum shall be included with the Contractor's Quality Control Plan in accordance with the specifications:
  - 1. Aggregates
    - a. For each material and/or different source, the laboratory shall perform soundness, gradation, and other tests for all parameters specified. Aggregates incorporated into concrete or asphalt mixes shall also be tested for moisture content daily.

2. **Compaction Tests**
  - a. Compaction tests or field density tests shall be taken on all embankment, trench backfill, subgrade, and subbase materials.
  - b. Minimum testing shall be as follows:  
Embankment testing shall be at least one (1) test/5,000 SF of each lift; Trench backfill testing shall be at least one (1) test/50 LF of each lift; Subgrade and/or subbase testing shall be at least one (1) test/200 LF of pavement or 5,000 SF of slabs; subject to greater frequency due to soil conditions or Engineer's direction.
  - c. Proctors or relative density tests shall be performed as often as necessary for the differing soils or granular materials utilized. Proctors shall be run with a minimum of 5 points. Test reports shall show the wet (bulk) weight, dry weight, wet (bulk) density, dry density, moisture content weight and moisture content percentage. Both the dry curve and the wet curve shall be plotted.
3. **Concrete Mix Design**
  - a. For each type of concrete, the laboratory shall perform the necessary mix design providing all test data as required by the specifications.
4. **Concrete Field and Laboratory Tests**
  - a. The laboratory shall cast concrete cylinders and test beams:
    1. One set of four cylinders per 50 CY with a minimum of two sets per day. The cylinders shall be broken: one at 7 days, two at 28 days, one at 56 days, unless otherwise directed by the Engineer.
    2. One beam per 50 CY with a minimum of two beams per day.
  - b. Temperature and unit weight shall be run on fresh concrete at intervals sufficient for the type of structure being placed and a minimum of once per day. Bulk weight, bucket weight, (tare), net weight, bucket factor (bucket volume) and unit weight shall be recorded on the fresh concrete report. Show all batch weights for yield calculations. Slump and air content tests shall be taken a minimum of one test per 20 CY and at least once per day.
  - c. All field and laboratory testing shall be performed by technicians certified by the American Concrete Institute (ACI) for the type of testing performed.
  - d. Initial cure of all cylinders shall be in a temperature controlled cure box or temperature controlled water tank with a hi-low thermometer. Hi-low temperature readings shall be recorded on the fresh concrete report.
5. **Asphalt Mix Design**
  - a. For each type of asphalt mix, submit job mix formula (JMF) prepared by an ODOT pre-qualified laboratory from tests performed on the aggregates proposed for use.
  - b. Sample and test for gradation and bitumen content per ODOT 441.

### 1.3 LABORATORY REPORTS

- A. Reports of laboratory and field tests will be distributed to the Engineer, Owner, and Suppliers within 24 hours of completion.

END OF SECTION 013319.01

## SECTION 013323 - SHOP DRAWINGS, PRODUCT DATA AND SAMPLES

### PART 1 - GENERAL

#### 1.1 GENERAL

- A. The Contractor shall submit detailed drawings, acceptable catalog data, specifications and material certifications for all equipment and materials specified or required for the proper completion of the work.
- B. The intent of these items is to demonstrate compliance with the design concept of the work and to provide the detailed information necessary for the fabrication, assembly and installation of the work specified. It is not intended that every detail of all parts of manufactured equipment be submitted, however sufficient detail will be required to ascertain compliance with the specifications and establish the quality of the equipment proposed.

Shop Drawings shall be sufficiently clear and complete to enable the Engineer/Architect and Owner to determine that items proposed to be furnished conform to the specifications and that items delivered to the site are actually those that have been reviewed.

- C. It is emphasized that the Engineer/Architect's review of Contractor's submitted data is for general conformance to the contract drawings and specifications but subject to the detailed requirements of drawings and specifications. Although the Engineer/Architect may review submitted data in detail, such review is an effort to discover errors and omissions in Contractor's drawings. The Engineer/Architect's review shall in no way relieve the Contractor of his obligation to properly coordinate the work and to Engineer/Architect the details of the work in such manner that the purposes and intent of the contract will be achieved. Such review by the Engineer/Architect shall not be construed as placing on him or on the Owner any responsibility for the accuracy and for proper fit, functioning or performance of any phase of the work included in the contract.
- D. Shop Drawings shall be submitted in proper sequence and with due regard to the time required for checking, transmittal and review so as to cause no delay in the work. The Contractor's failure to transmit appropriate submittals to the Engineer/Architect sufficiently in advance of the work shall not be grounds for time extension.
- E. The Contractor shall submit Shop Drawings for all fabricated work and for all manufactured items required to be furnished in the Contract in accordance with the General Provisions and as specified herein. Shop Drawings shall be submitted in sufficient time to allow at least twenty-one (21) calendar days after receipt of the Shop Drawings from the Contractor for checking and processing by the Engineer/Architect.
- F. It is the responsibility of each Prime Contractor to furnish to all other Prime Contractors and especially the General Construction Contractor reviewed Shop Drawings for guidance in interfacing the various trades; i.e., sleeves, inserts, anchor bolts, terminations, and space requirements.

- G. No work shall be performed requiring Shop Drawings until same have been reviewed by Engineer/Architect.
- H. Accepted and reviewed Shop Drawings shall not be construed as approval of changes from Contract plan and specification requirements.
- I. The Engineer/Architect will review the first and second Shop Drawing item submittals at no cost to the Contractor. Review of the third submittal and any subsequent submittal will be at the Contractor's expense. Payment will be deducted from the Contract amount at a rate of 2.8 times direct labor cost plus expenses.

## 1.2 SUBMITTAL PROCEDURE

- A. All required submissions shall be made to the Engineer/Architect by the Prime Contractor(s) only. Any data prepared by subcontractors and suppliers and all correspondence originating with subcontractors, suppliers, etc., shall be submitted through the Contractor.
- B. Contractor shall review and approve all Shop Drawings prior to submission. Contractor's approval shall constitute a representation to Owner and Engineer/Architect that Contractor has either determined and verified all quantities, dimensions, field construction criteria, materials, catalog numbers, and similar data or assumes full responsibility for doing so, and that Contractor has reviewed or coordinated each Shop Drawing or sample with the requirements of the work and the Contract Documents.
- C. Submittal Preparation: Mark each submittal with a permanent label or page for identification. Provide the following information on the label for proper processing and recording of action taken:
  - 1. Location
  - 2. Project Name
  - 3. Contract
  - 4. Name and Address of Engineer/Architect
  - 5. Name and Address of Contractor
  - 6. Name and Address of Subcontractor
  - 7. Name and Address of Supplier
  - 8. Name of Manufacturer
  - 9. Number and Title of appropriate Specification Section
  - 10. Drawing Number and Detail References, as appropriate.
  - 11. Submittal Sequence or Log Reference Number.
    - a. Provide a space on the label for the Contractor's review and approval markings and a space for the Engineer/Architect's "Action Stamp".
- D. Each Shop Drawing, sample and product data submitted by the Contractor shall have affixed to it the following Certification Statement including the Contractor's Company name and signed by the Contractor:



Certification Statement: By this submittal, I hereby represent that I have determined and verified all field measurements, field construction criteria, materials, dimensions, catalog numbers and similar data and I have checked and coordinated each item with other applicable approved shop drawings and all Contract requirements.

\_\_\_\_\_  
Signature

\_\_\_\_\_  
Date

\_\_\_\_\_  
Company

- E. Shop Drawings shall be submitted in not less than six (6) copies to the Engineer/Architect at the address specified at the Preconstruction Conference. Single mylar or sepia reproducible copies of simple Shop Drawings may be submitted with prior approval of the Engineer/Architect.
- F. At the time of each submission, Contractor shall in writing identify any deviations that the Shop Drawings or samples may have from the requirements of the Contract Documents.
- G. Drawings shall be clean, legible and shall show necessary working dimensions, arrangement, material finish, erection data, and like information needed to define what is to be furnished and to establish its suitability for the intended use. Specifications may be required for equipment or materials to establish any characteristics of performance where such are pertinent. Suitable catalog data sheets showing all options and marked with complete model numbers may, in certain instances, be sufficient to define the articles which it is proposed to furnish.
- H. For product which require submittal of samples, furnish samples so as not to delay fabrication, allowing the Engineer reasonable time for the consideration of the samples submitted. Properly label samples, indicating the material or product represented, its place of origin, the names of the vendor and Contractor and the name of the project for which it is intended. Ship samples prepaid. Accompany samples with pertinent data required to judge the quality and acceptability of the sample, such as certified test records and, where required for proper evaluation, certified chemical analyses.

### 1.3 REVIEW PROCEDURE

- A. Engineer/Architect will review with reasonable promptness all properly submitted Shop Drawings. Such review shall be only for conformance with the design concept of the Project and for compliance with the information given in the plans and specifications and shall not extend to means, methods, sequences, techniques or procedures of construction or to safety precautions or programs incident thereto.
- B. The review of a separate item as such will not constitute the review of the assembly in which the item functions. The Contractor shall submit entire systems as a package.
- C. All Shop Drawings submitted for review shall be stamped with the Engineer/Architect's action and associated comments.

- D. Except for submittals for record, information or similar purposes, where action and return is required or requested, the Engineer/Architect will review each submittal, mark to indicate action taken, and return accordingly. Compliance with specified characteristics is the Contractor's responsibility.

Action Stamp: The Engineer/Architect will stamp each submittal with a uniform, self-explanatory action stamp. The stamp will be appropriately marked, as follows, to indicate the action taken:

1. If Shop Drawings are found to be in general compliance, such review will be indicated by marking the first statement.
  2. If only minor notes in reasonable number are needed, the Engineer/Architect will make same on all copies and mark the second statement. Shop Drawings so marked need not be resubmitted.
  3. If the submitted Shop Drawings are incomplete or inadequate, the Engineer/Architect will mark the third statement, request such additional information as required, and explain the reasons for revision. The Contractor shall be responsible for revisions, and/or providing needed information, without undue delay, until such Shop Drawings are acceptable. Shop Drawings marked with No. 3 shall be completed resubmitted.
  4. If the submitted Shop Drawings are not in compliance with the Contract Documents, the Engineer/Architect will mark the fourth statement. The Contractor will be responsible to submit a new offering conforming to specific products specified herein and/or as directed per review citations.
- E. No submittal requiring a Change Order for either value or substitution or both, will be returned until the Change Order is approved or otherwise directed by the Owner.

# APPLICATION FOR USE OF SUBSTITUTE ITEM

TO: \_\_\_\_\_

PROJECT: \_\_\_\_\_

SPECIFIED ITEM:

Page	Paragraph	Description
A.		The undersigned requests consideration of the following as a substitute item in accordance with Article 6.05 of the General Conditions.
B.		Change in Contract Price (indicate + or -) \$ _____
C.		Attached data includes product description, specifications, drawings, photographs, references, past problems and remedies, and performance and test data adequate for evaluation of the request; applicable portions of the data are clearly identified. For consideration of the attached data as SHOP DRAWINGS, submittal shall be in accordance with requirements of Section 013323.
D.		Attached data also includes a description of changes to the Contract Documents that the proposed substitution will require for its proper installation.

The undersigned certifies that the following paragraphs, unless modified by attachments are correct:

1. The proposed substitute does not affect dimensions shown on Drawings.
2. The undersigned will pay for changes to the building design, including engineering design, detailing, and construction costs caused by the requested substitution.
3. The proposed substitution will have no adverse affect on other contractors, the construction schedule, or specified warranty requirements. (If proposed substitution affects construction schedule, indicate below using + or -)

\_\_\_\_\_ CONSECUTIVE CALENDAR DAYS

4. Maintenance and service parts will be locally available for the proposed substitution.

The undersigned further states that the function, appearance, and quality of the proposed substitution are equivalent or superior to the specified item, and agrees to reimburse the OWNER for the charges of the ENGINEER for evaluating this proposed substitute item.

E. Signature:

Firm:

Address:

Telephone:

Date:

Attachments:

For use by ENGINEER:

\_\_\_\_\_ Accepted as evidenced by affixed SHOP DRAWING REVIEW stamp.

\_\_\_\_\_ Accepted as evidenced by included CHANGE ORDER.

\_\_\_\_\_ Not accepted as submitted. See Remarks.

\_\_\_\_\_ Acceptance requires completion of submittal as required for SHOP DRAWINGS.

\_\_\_\_\_ Not accepted. Do not resubmit.

By:

Date:

Remarks:

# APPLICATION FOR USE OF "OR-EQUAL" ITEM

TO: \_\_\_\_\_

PROJECT: \_\_\_\_\_

SPECIFIED ITEM:

Page	Paragraph	Description
------	-----------	-------------

A. The undersigned requests consideration of the following as an "or-equal" item in accordance with Article 6.05 of the General Conditions.

B. Change in Contract Price (indicate + or -) \$ \_\_\_\_\_

C. Attached data includes product description, specifications, drawings, photographs, references, past problems and remedies, and performance and test data adequate for evaluation of the request; applicable portions of the data are clearly identified. For consideration of the attached data as SHOP DRAWINGS, submittal shall be in accordance with requirements of Section 013323.

D. Signature:

Firm: \_\_\_\_\_

Address: \_\_\_\_\_  
\_\_\_\_\_  
\_\_\_\_\_

Telephone: \_\_\_\_\_ Date: \_\_\_\_\_

Attachments: \_\_\_\_\_  
\_\_\_\_\_  
\_\_\_\_\_  
\_\_\_\_\_

For use by ENGINEER:

\_\_\_\_\_ Accepted as evidenced by affixed SHOP DRAWING REVIEW stamp.

\_\_\_\_\_ Accepted as evidenced by included CHANGE ORDER.

\_\_\_\_\_ Not accepted as submitted. See Remarks.

\_\_\_\_\_ Acceptance requires completion of submittal as required for SHOP DRAWINGS.

\_\_\_\_\_ Not accepted. Do not resubmit.

By: \_\_\_\_\_ Date: \_\_\_\_\_

Remarks: \_\_\_\_\_  
\_\_\_\_\_  
\_\_\_\_\_  
\_\_\_\_\_  
\_\_\_\_\_  
\_\_\_\_\_  
\_\_\_\_\_  
\_\_\_\_\_  
\_\_\_\_\_  
\_\_\_\_\_  
\_\_\_\_\_

END OF SECTION 013323

## SECTION 013326 – PRODUCT TESTING AND CERTIFYING

### PART 1 - GENERAL

#### 1.1 QUALITY OF MATERIALS

- A. Where the specifications call for mill or shop tests, the Contractor shall furnish duplicate copies of attested manufacturer's certificates showing details of quality or performance sufficient to demonstrate conformity to contract requirements. Mill, shop or witness tests shall be subject to view by the Engineer's representative, but the Engineer's representation shall not relieve the Contractor from the necessity of furnishing certificates specified. The Engineer shall be notified by the Contractor in writing, sufficiently in advance of the time of making tests, so that proper arrangements may be made. Waiving of witness of tests by the Engineer may be in writing only by the Engineer. All costs for travel, lodging, food and transportation that are necessary for the Engineer's representative and the Owner's representative to attend witness tests shall be included in the Contractor's bid for those item(s) specifically designated as being subject to witness testing.
- B. Unless otherwise specified, all materials, equipment and articles shall be erected, installed, applied, or connected, used, cleaned and conditioned in accordance with the printed instructions and directions of the manufacturer.
- C. The installation shall be so made that its several component parts will function together as a workable system. It shall be complete with all accessories necessary for its operation and shall be left with all equipment properly adjusted and in working order.
- D. The work shall be executed in conformity with the best practice and so as to contribute to efficiency of operation, minimum maintenance, accessibility and sightliness. It shall also be executed so that the installation will conform and accommodate itself to the building structure, its equipment and usage.
- E. Whenever in the contract documents a particular brand, make of material, device or equipment is shown or specified, such brand, make of material, device or equipment is to be regarded merely as a standard and such trade name shall be followed by "or equal".

#### 1.2 QUALITY ASSURANCE

- A. The equipment and materials to be furnished under this Contract shall be the products of well established and reliable firms which have had ample experience for at least five (5) years in the manufacture of equipment or materials similar in design and of equal quality to that specified. If required, the manufacturer shall submit a list of installations of similar equipment which have been in successful operation for at least five (5) years.

#### 1.3 EXPERIENCE CLAUSE REQUIREMENT AND PERFORMANCE BONDS FOR MANUFACTURER

- A. For every piece of equipment furnished under this Contract, the manufacturer will be required to have a minimum of five (5) years of experience in providing this specific type of equipment. In lieu of this experience requirement, the manufacturer will be required to provide performance bond(s) for the faithful performance of the equipment and guarantee payment in a sum of not less than one hundred and fifty percent (150%) of the total equipment price for the completed work for that item. In the absence of verifiable experience, the manufacturer will be required to provide the performance bond(s) for the same number of years that the manufacturer was found lacking in experience from the specified five (5) year period. The performance bond(s) shall be from an approved surety company, to the satisfaction of the Owner's Law Director.
- B. Agents of bonding companies which write bonds for the performance and payment of the contract shall furnish power of attorney bearing the seal of the company, evidencing such agent's authority to execute the particular type of bond to be furnished, and evidencing also the right of the surety company to do business in the State of Ohio. Copy of this proof shall be attached to each copy of the contract.
- C. The bond shall be purchased through a surety company with a local agent upon whom service of process can be made.
- D. In event of failure of surety or co-surety, the manufacturer shall immediately furnish a new bond, as required herein. The manufacturer's bond will not be released until all provisions of the contract have been fulfilled.
- E. The surety used for the bid bond and performance bond shall be listed in the latest U.S. Treasury Circular 570 and the Penal Sums shall be within the maximum specified for such company in said Circular 570.

END OF SECTION 013326



## SECTION 013543 - ENVIRONMENTAL PROTECTION

### PART 1 - GENERAL

#### 1.1 UNNECESSARY NOISE, DUST AND ODORS

- A. The Contractor's performance of this contract shall be conducted so as to eliminate all unnecessary noise, dust and odors.

#### 1.2 SEWAGE, SURFACE AND FLOOD FLOWS

- A. The Contractor shall take whatever action is necessary to provide all necessary tools, equipment and machinery to adequately handle all sewage, surface flows and flood flows which may be encountered during the performance of the work. The entire cost of and liability for handling such flows is the responsibility of the Contractor and shall be included in the price for the appropriate item.

#### 1.3 WORK IN FREEZING WEATHER

- A. Written permission from the Engineer shall be obtained before any work is performed which, in the judgment of the Engineer, may be affected by frost, cold, or snow. When work is performed under such conditions, the Contractor shall provide facilities for heating the materials and for protecting the finished work.

#### 1.4 POLLUTION CONTROL

- A. It shall be the responsibility of the Contractor to prevent or limit pollution of air and water resulting from his operations.
- B. The Contractor shall perform work required to prevent soil from eroding or otherwise entering onto all paved areas and into natural watercourses, ditches, and public sewer systems. This work shall conform to all local ordinances and/or regulations, if any, and if not otherwise regulated by local ordinances or regulations shall at a minimum conform to the Ohio EPA General Storm Water NPDES Permit for Construction Activities and the Ohio Department of Natural Resources Rainwater and Land Development manual. This work may consist of but not be limited to construction and continual maintenance of silt fence, bio bag filters, sedimentation traps, stilling basins, check dams, temporary seeding, temporary mulching, erosion mats and other means to clarify waters containing suspended materials from excavations, embankments, cleared and grubbed or stripped areas, stockpiles, well points, and disposal sites and shall be commensurate with the contractor's schedule, sequence of work, means and methods. If a SWPPP plan is not required for the project, the contractor shall at a minimum submit a plan of his proposed erosion control prevention methods for approval by the Owner and/or other regulatory authorities having jurisdiction prior to starting any construction activities which may cause erosion.

- C. The Contractor shall perform work required to prevent dust attributable to his operations from entering the atmosphere. Dust on unsurfaced streets or parking areas and any remaining dust on surfaced streets shall be controlled with water and/or calcium chloride dust palliative as needed.
- D. Any material removed from sanitary or storm sewers shall be disposed in accordance with all applicable regulations.

END OF SECTION 013543

## SECTION 014126 - GENERAL REGULATIONS AND PERMITS

### PART 1 - GENERAL

#### 1.1 REGISTRATION

All Contractors and subcontractors shall be registered with the Building Department having jurisdiction. Contact the Building Department for additional registration information.

#### 1.2 PERMITS

The Contractor shall apply for and pay for all permits from the Owner and/or other authorities having jurisdiction.

#### 1.3 ARCHAEOLOGICAL DISCOVERIES

Contractors and subcontractors are required under O.R.C. Section 149.53, to notify the Ohio Historical Society and the Ohio Historic Site Preservation Board of Archaeological Discoveries located in the project area, and to cooperate with those entities in archaeological and historic surveys and salvage efforts if such discoveries are uncovered within the project area.

Contact:       Department Head  
                  Resource Protection and Review  
                  Ohio Historic Preservation Office  
                  800 E. 17th Avenue  
                  Columbus, Ohio 43211-2497  
                  614-298-2000

Should archaeological discoveries or other activities delay progress of the work, an adjustment in contract time will be made.

END OF SECTION 014126

## SECTION 014223 - INDUSTRY STANDARDS

### PART 1 - GENERAL

#### 1.1 ABBREVIATIONS

- A. Abbreviations, as used, designate the following:

AASHTO	-	American Association of State Highway and Transportation Officials
ACI	-	American Concrete Institute
AIEE	-	American Institute of Electrical Engineers
AISC	-	American Institute of Steel Construction
ANSI	-	American National Standards Institute
ASTM	-	American Society of Testing and Materials
AWWA	-	American Water Works Association
CMS	-	Construction and Material Specifications
NEMA	-	National Electrical Manufacturers Association
ODOT	-	Ohio Department of Transportation
ORC	-	Ohio Revised Code
UL	-	Underwriters Laboratories, Inc.

#### 1.2 REFERENCE TO OTHER SPECIFICATIONS

- A. Where reference is made to specifications such as ASTM, AWWA or AASHTO, the latest edition shall be used, unless otherwise noted on the plans or in the specifications.

#### 1.3 CODES AND STANDARDS

- A. All work provided for by these specifications must be installed according to the provisions of the State and local building codes, subject to inspection and acceptance by the State and local inspectors.

END OF SECTION 014223

## SECTION 014323 – QUALIFICATIONS OF TRADESMEN

### PART 1 - GENERAL

#### 1.1 CHARACTER OF WORKMEN AND EQUIPMENT

- A. The Contractor shall employ competent and efficient workmen for every kind of work. Any person employed on the work who shall refuse or neglect to obey directions of the Engineer or his representative, or who shall be deemed incompetent or disorderly, or who shall commit trespass upon public or private property in the vicinity of the work, shall be dismissed when the Engineer so orders, and shall not be re-employed unless express permission be given by the Engineer. The methods, equipment and appliances used on the work and the labor employed shall be such as will produce a satisfactory quality of work, and shall be adequate to complete the contract within the specified time limit.
  
- B. In hiring of employees for the performance of work under this Contract, or any Subcontract hereunder, no Contractor or Subcontractor, nor any person acting on behalf of such Contractor or Subcontractor, shall, by reason of race, sex, creed or color, discriminate against any citizen of the State of Ohio in the work to which the employment relates. No Contractor, Subcontractor, nor any person on his behalf shall, in any manner, discriminate against or intimidate any employee hired for the performance of work under this contract on account of race, creed, sex or color.

END OF SECTION 014323

## SECTION 015100 - TEMPORARY POWER SERVICE

### PART 1 - GENERAL

#### 1.1 ELECTRICAL POWER

- A. The Contractor shall furnish at his own expense all electrical power which may be required for the project. All temporary lines shall be furnished and installed by the Contractor at his own expense in a manner which meets the approval of the Engineer, and shall be removed by the Contractor at the completion of the construction.

END OF SECTION 015100

## SECTION 015136 - TEMPORARY WATER AND DISTRIBUTION

### PART 1 - GENERAL

#### 1.1 WATER

- A. The Contractor shall be responsible for an adequate supply of water suitable for his use for construction and drinking. At his own expense, he shall provide and maintain adequate supplies and supply lines in such locations and installed in such a manner as may be satisfactory to the Engineer.

END OF SECTION 015136

## SECTION 015526 - TEMPORARY TRAFFIC CONTROL DEVICES

### PART 1 - GENERAL

#### 1.1 BARRICADES, SIGNS AND LIGHTS

- A. The Contractor shall employ watchmen on the work when and as necessary. The Contractor shall erect and maintain such strong and suitable barriers and such lights as will effectively prevent the occurrence of any accident to health, limb or property. Lights shall be maintained between the hours of one-half (1/2) hour after sunset and one-half (1/2) hour before sunrise.
- B. No manhole, trench, excavation will be left open awaiting connection or removal at a later date by the Contractor's forces or others but shall be temporarily backfilled and resurfaced if applicable with a temporary pavement passable to traffic at no additional cost to the Owner.
- C. In addition to other safety requirements, a minimum of four (4) foot high fence will be incorporated around any shaft or manhole or other excavation left open at the end of a day's work.

#### 1.2 MAINTENANCE OF TRAFFIC

- A. The Contractor is required to provide maintenance of traffic in conformance with the Ohio Manual of Uniform Traffic Control Devices and Item 614 of the current Construction and Material Specifications of the Ohio Department of Transportation.
- B. This work shall include providing suitable and satisfactorily trained and properly attired flagmen for use at any location where existing roadway is narrowed to a width of less than 2 full lanes (18 feet).
- C. The Contractor is also responsible for maintaining local access to all residences and businesses along the route of the construction and to provide whatever temporary materials are necessary to provide a safe, adequate drive surface.
- D. At all boring locations, Contractor shall provide suitable flashers, barricades, and traffic control devices as may be deemed necessary by the Engineer or the responsible authority in the case of the Department of Transportation, Turnpike Commission, or affected railroad. This may extend to maintain facilities on a 24-hour basis until such time as the areas are completely backfilled.

END OF SECTION 015526



## SECTION 015800 - PROJECT IDENTIFICATION

### PART 1 - GENERAL

#### 1.1 PROJECT SIGN

- A. The Contractor shall be responsible for constructing, installing, maintaining and removing all project signs.
- B. The Contractor shall be responsible for obtaining all permits for project signs from any local authority having jurisdiction including the payment of fees, if any.
- C. The contractor shall install one project sign at a location to be determined by the Owner. The sign shall contain all of the data and graphics depicted on the attached exhibit **SD-6-16 C**.
- D. **See Bid Book Special Requirements – EPA, Signage pages SR.EPA.45 to 48.**

END OF SECTION 015800

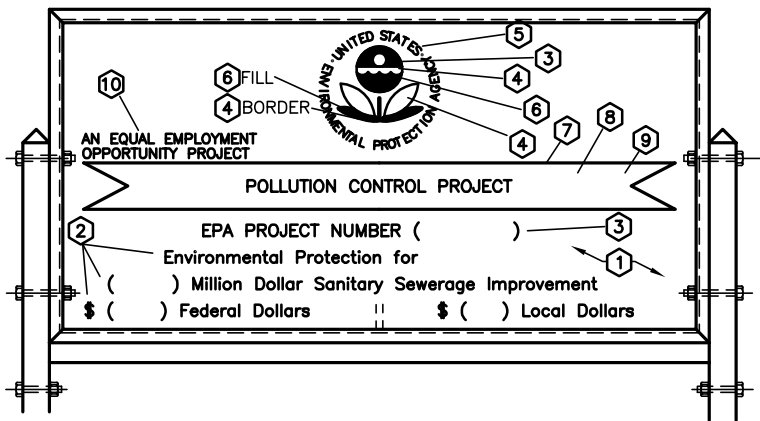

- ⑤ 1 1/2" LETTERS
- ⑥ DARK GREEN
- ⑦ 1/2" DARK GREEN BORDER
- ⑧ BLUE 3" LETTERS
- ⑨ YELLOW
- ⑩ BLUE 1" BLUE LETTERS

EPA

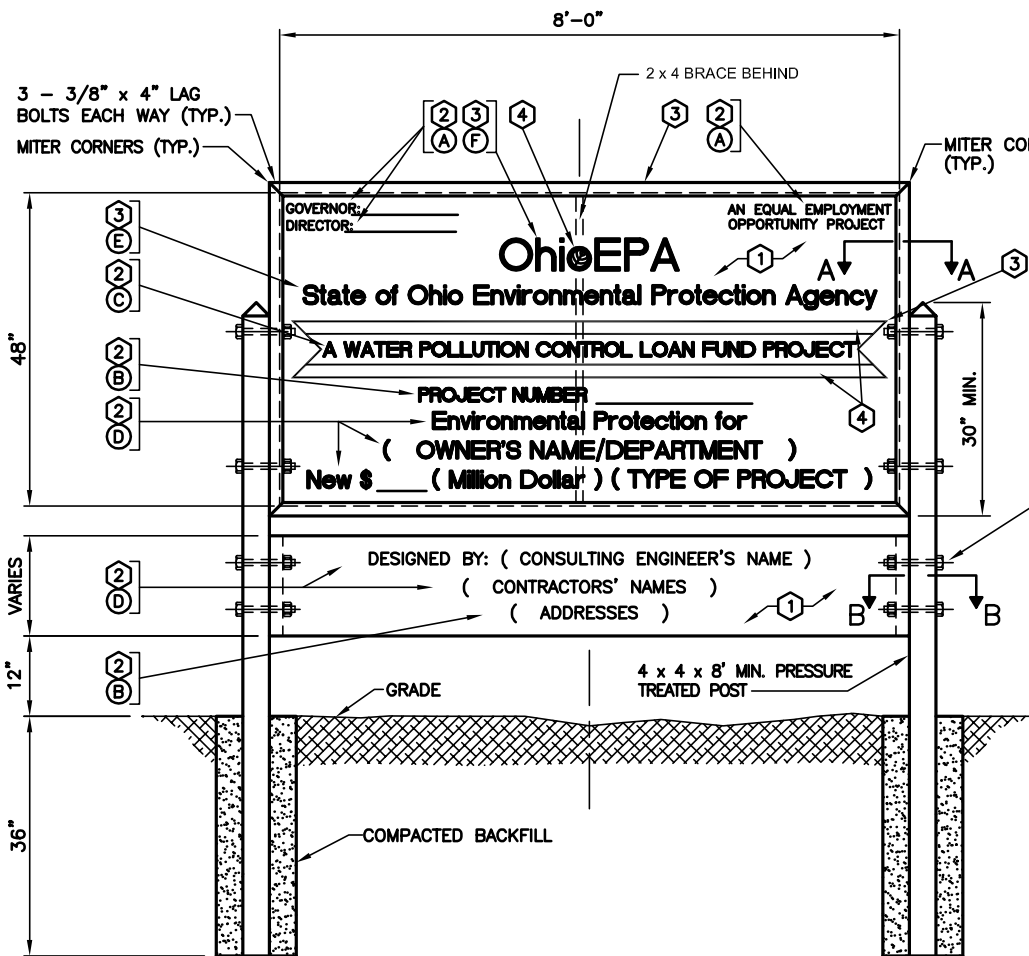

PAINT LEGEND

ALL PAINT TO BE OUTDOOR ENAMEL. COLOR NUMBERS REFER TO FEDERAL COLOR STANDARD NO. 595 (1-68) WHICH ARE AVAILABLE AT OSA SUPPLIES.

- ① BACKGROUND, POST AND SIGN BACK TO BE WHITE 1 COAT PRIME 2 COATS FINISH
- ② BLACK NO. 17038 UNLESS OTHERWISE NOTED.
- ③ BLUE NO. 15180
- ④ LITE GREEN MIX - 5 PARTS NO. 15655 TO 1 PART NO. 15180

SIZE LEGEND

- (A) = 1 1/2"      (D) = 2 1/2"
- (B) = 2"          (E) = 2 3/4"
- (C) = 2 1/4"      (F) = 5"

- 3/8" x 8" HEX HEAD BOLTS WITH WASHERS (TYP.)
- 2 x 6 PRESSURE TREATED FRAME
- 3/4" MIN. PRESSURE TREATED EXTERIOR GRADE PLYWOOD A/B VENEERS

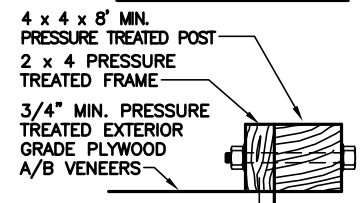
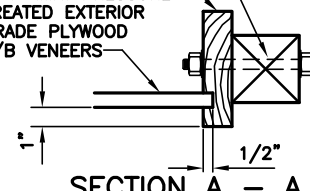

PROJECT SIGN DETAIL

N.T.S.

SD-6-16C

---

---

# INVESTING IN AMERICA

---

---

## Investing In America Signage Guidelines

The Bipartisan Infrastructure Law

The CHIPS and Science Act

The Inflation Reduction Act

The American Rescue Plan



## Guidelines for Logo Applications

The purpose of this document is to provide general guidelines for signs displayed at project sites for projects funded under the Bipartisan Infrastructure Law (also known as the Infrastructure Investment and Jobs Act), the CHIPS and Science Act, the Inflation Reduction Act, the American Rescue Plan, and other Federally-funded projects as appropriate. The first part of this document pertains to signs for Federally-funded projects that are not installed in the highway right-of-way. For highway signage guidance that is MUTCD compliant please see pages 13 and 14. For all other signs please start here. This document provides information about the Investing In America logo mark as well as how logos, marks and seals of states, cities, and counties can be incorporated into signage. Logos of contractors are not permitted on the signage. When logos are included in signage, the placement should conform to these brand guidelines.

## Variations and Usage

There is one approved mark associated with the Investing In America logo. To preserve the integrity of the Investing In America logo mark, make sure to apply them correctly. Altering, distorting, or recreating the 'marks' in any way weakens the power of the image and what it represents. Layout and design of signs and communication materials will vary, so care must be taken when applying the logo mark.

## Primary Logo Mark

---

---



# INVESTING IN AMERICA

---

---

## Colors

The colors, graphics, and fonts used should conform to graphic standards.

COLOR	CMYK	RGB	HEX	PMS
 <b>Blue</b>	83, 48, 0, 48	22 / 68 / 132	#164484	PMS 7687 C
 <b>Red</b>	0, 100, 81, 0	255 / 0 / 49	#FF0031	PMS 185 C
 <b>White</b>	2, 2, 0, 3	242 / 244 / 248	#F2F4F8	Bright White

Logos



White background: logo in red and blue



Gray background: logo in red and blue



Blue background: logo in all white

# Investing In America General Guidelines for Logo Applications

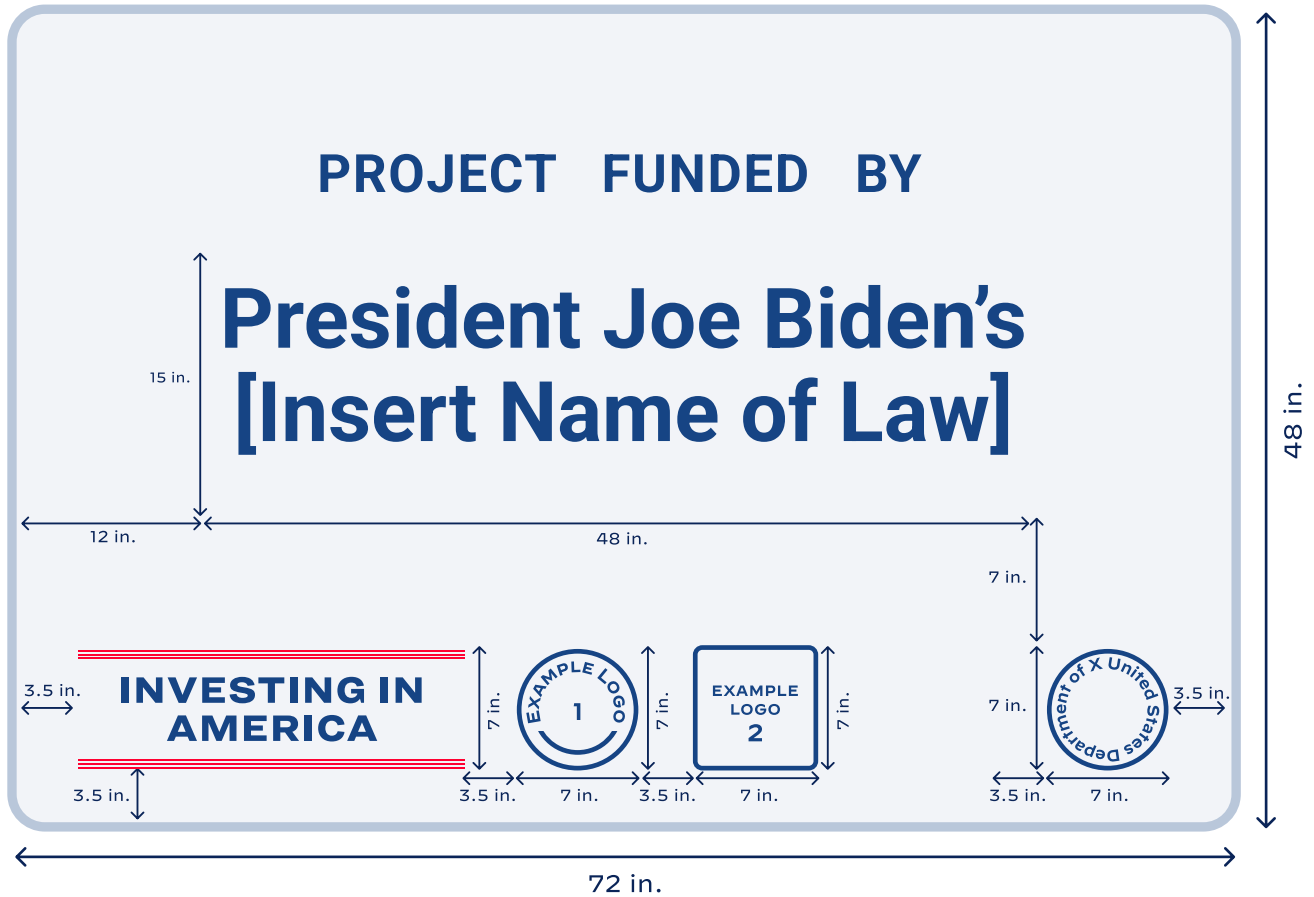

# Sign Colors

## 1. The Bipartisan Infrastructure Law



White



Gray



Blue

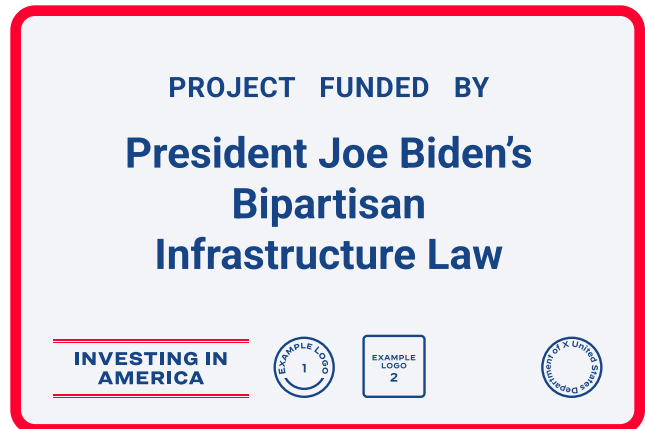

Red Border



## Sign Colors

### 2. The CHIPS and Science Act



White



Gray



Blue



Red Border

## Sign Colors

### 3. The Inflation Reduction Act



White

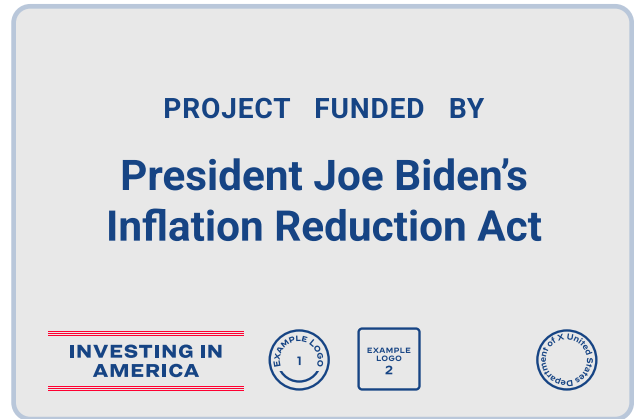

Gray



Blue



Red Border

## Sign Colors

### 4. The American Rescue Plan



White



Gray



Blue



Red Border

## State, City, and County Logo Variations



Square or Circular State Logo: 7x7 in.



Rectangular or Oval State Logo: **not** to exceed 17.5 x 7 in.

### 3 Logo Samples



Circular City Logo 7 x 7 in. State rectangular logo should **not** exceed 17.5 x7 in.

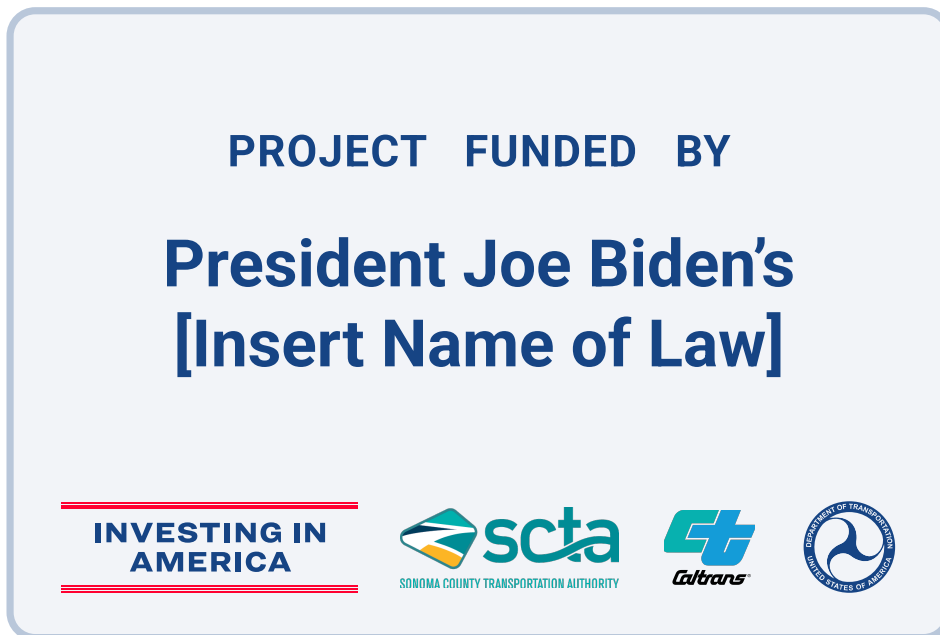

Rectangular State Logo: **not** to exceed 17.5 x 7 in.

## 2 Logo Samples



Circular State Logo: 7 x 7 in.



Rectangular State Logo: **not** to exceed 17.5 x 7 in.

## Rules for Highway Right of Way Signage 8 Feet

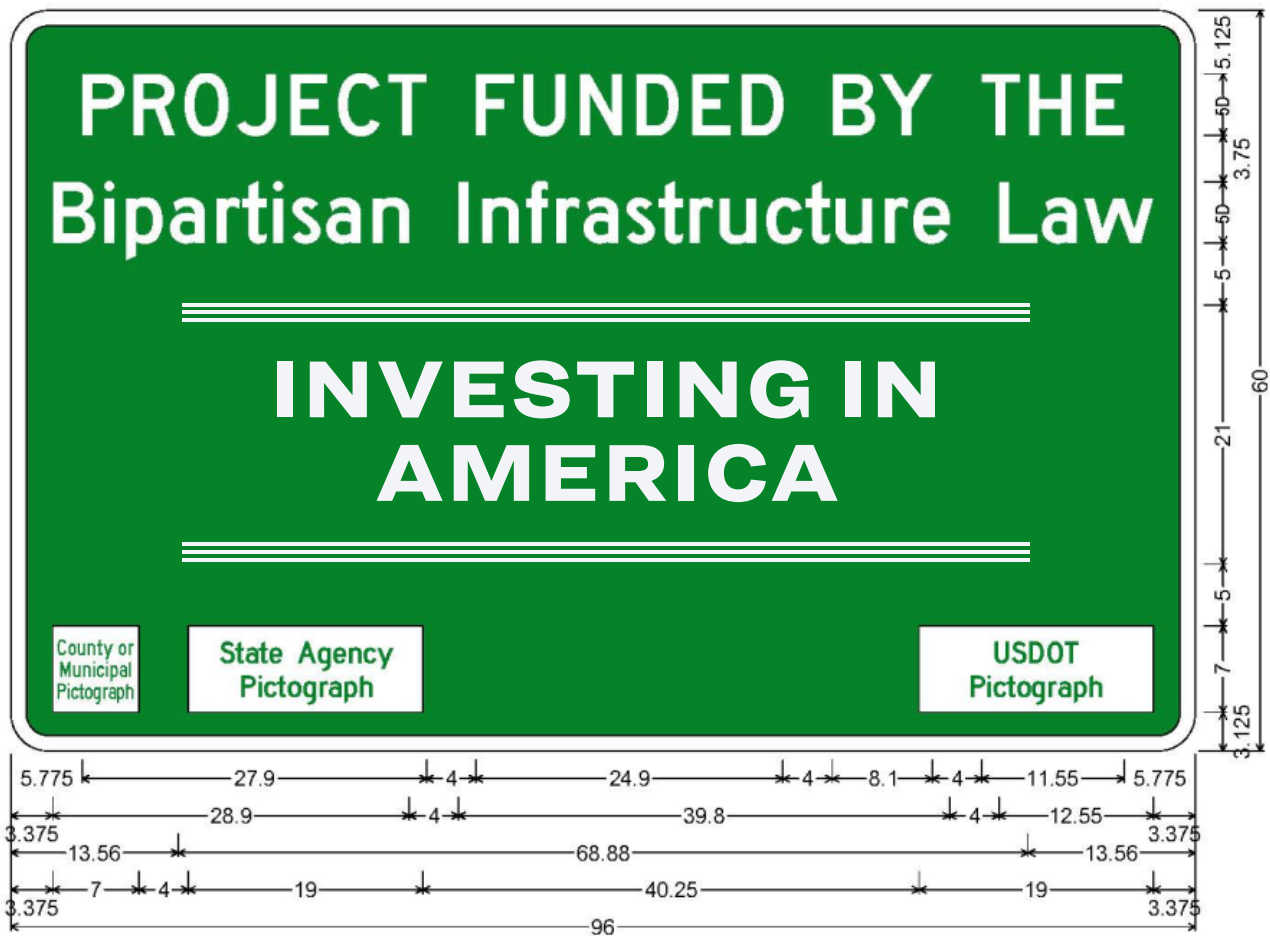

## Rules for Highway Right of Way Signage 6 Feet

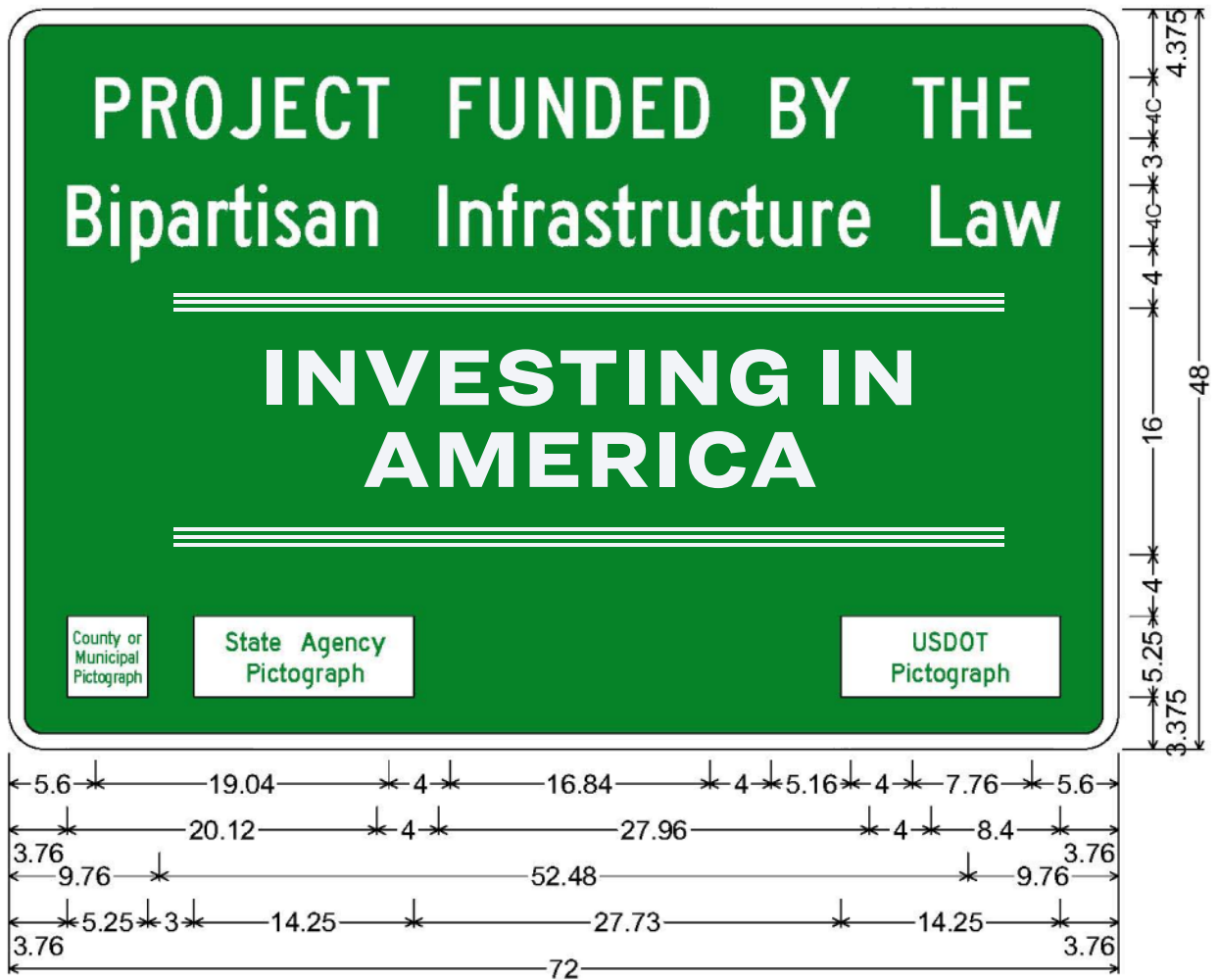



# EPA LOGO & SEAL SPECIFICATIONS FOR SIGNAGE PRODUCED BY EPA ASSISTANCE AGREEMENT RECIPIENTS

EPA's logo is a two-leaved flower, without stem, accompanied by the Agency's initials to the right. The EPA logo is the primary identifier for use on construction grant signage. Assistance agreement recipients are not required to receive EPA approval to use the EPA logo when used in accordance with the terms and conditions of their assistance agreement award.

The official seal of EPA is circular and is comprised of the two-leaved flower, with stem, encircled by the title UNITED STATES ENVIRONMENTAL PROTECTION AGENCY. The EPA seal may be used only when official comparable seals are used and the recipient has received prior written EPA approval.

It is important that the EPA logo and seal always be reproduced with consistent high quality. The seal and logo must remain intact and unchanged (for example, don't use the flower from the seal by itself). The logo and seal may only be displayed using either the standard color scheme or a single color that complements the background where it appears.

## COLOR AND SPACING

- The entire logo and seal must appear in black, gray, or any uniform color or knock out white on a dark background. The flower and text may not be different colors. The flower itself may not contain more than one color. The seal can be monotone or full color, based on the rest of the seals that it's placed with.
- The relationship between the flower portion of the logo and Helvetica type should never be shifted or adjusted.



## PREFERRED USE

Use the preferred presentation of the logo on products that do not have enough space for the full logo with text. It may also be used in the presence of other logos.



## SIZE AND LOGO WITH OTHER LOGOS

It's important that all parts of the EPA logo be readable. The EPA logo should not be reproduced at sizes any smaller than 1.0" height on a sign. There are no maximum size restrictions as long as the clear space requirements are met. The logo should be made the same relative size as the other logos on the signage.



## SIZE AND SEAL WITH OTHER SEALS

When there are multiple state or Federal seals/circular logos, the use of the EPA seal is appropriate with prior written EPA approval. The EPA seal should be the same size as the seals that accompany it and should be a minimum of 3 inches in height.



## IMPROPER LOGO USAGE



## SECTION 016600 - PRODUCT HANDLING AND PROTECTION

### PART 1 - GENERAL

#### 1.1 DELIVERY AND STORAGE OF MATERIALS

- A. The Contractor shall be responsible for delivery and storage of all materials.
- B. The Contractor shall coordinate with the Engineer on the arrangement for storing construction materials and equipment. Deliveries of all construction materials and equipment should be made at suitable times.
- C. The Contractor shall store all materials required for the performance of this contract at sites designated by the Engineer.
- D. All stockpiles shall be neat, compact, completely safe, and barricaded with warning lights if necessary.
- E. Precautions shall be taken so that no shade trees, shrubs, flowers, sidewalks, driveways or other facilities will be damaged by the storage of materials. The Contractor shall be responsible for the restoration of all stockpile sites to their original condition.
- F. Materials, tools and machinery shall not be piled or placed against shade trees, unless they shall be amply protected against injury therefrom. All materials, tools, machinery, etc. stored upon public thoroughfares must be provided with red lights at night time so as to warn the traffic of such obstruction.
- G. Materials shall be so stored as to assure the preservation of their quality and fitness for the work. Stored materials, even though approved before storage, shall again be inspected prior to their use in the work. Stored materials shall be located so as to facilitate their prompt inspection. Approved portions of the construction site may be used for storage purposes and for the placing of the Contractor's plant and equipment, but any additional space required therefore must be provided by the Contractor at his expense. Private property shall not be used for storage purposes without written permission of the property owner or lessee, and copies of such written permission shall be furnished the Engineer. All storage sites shall be restored to their original condition by the Contractor at his expense.

END OF SECTION 016600

## SECTION 017800 - FINAL COMPLIANCE AND SUBMITTALS

### PART 1 - GENERAL

- 1.1 The following forms and related sign-offs shall be documented in accordance with provisions of the contract. These forms shall be completed by the Contractor and approved by the Owner before final retainer is approved for release. Forms for Items A to E will be attached to the Contractor's executed copy of the contract.
- A. Certificate of Substantial Completion (To be submitted at time of Substantial Completion).
  - B. Contractor's Certification of Completion.
  - C. Contractor's Affidavit of Prevailing Wage.
  - D. Consent of Surety Company for Final Payment.
  - E. Affidavit of Final Acceptance Date and Correction Period.
  - F. Before the OWNER will approve and accept the work and release the retainer, the CONTRACTOR will furnish the OWNER a written report indicating the resolution of any and all property damage claims filed with the CONTRACTOR by any party during the construction period. The information to be supplied shall include, but not be limited to, name of claimant, date filed with CONTRACTOR, name of insurance company and/or adjuster handling claim, how claim was resolved and if claim was not resolved for the full amount, a statement indicating the reason for such action.
  - G. DBE Subcontractor Participation Forms SR-EPA.7-8 (Applicable for WPCLF & WSRLA funded projects only).

END OF SECTION 017800

## SECTION 017821 - CLEANING AND PROTECTION

### PART 1 - GENERAL

#### 1.1 GENERAL

- A. On or before the completion date for the work, the Contractor shall tear down and remove all temporary structures built by him, all construction plant used by him, and shall repair and replace all parts of existing embankments, fences or other structures which were removed or injured by his operations or by the employees of the Contractor. The Contractor shall thoroughly clean out all buildings, sewers, drains, pipes, manholes, inlets and miscellaneous and appurtenant structures, and shall remove all rubbish leaving the grounds in a neat and satisfactory condition.
- B. As circumstances require and when ordered by the Engineer, the Contractor shall clean the road, driveway, and/or sidewalk on which construction activity under this contract has resulted in dirt or any other foreign material being deposited with an automatic self-contained mechanical sweeper with integral water spray, vacuum and on-board or supplementary containment.
- C. Failure to comply with this requirement when ordered by the Engineer or his representative, may serve as cause for the Engineer to stop the work and to withhold any monies due the Contractor until such order has been complied with to the satisfaction of the Engineer.
- D. As the work progresses, and as may be directed, the Contractor shall remove from the site and dispose of debris and waste material resulting from his work. Particular attention shall be given to minimizing any fire and safety hazard from form materials or from other combustibles as may be used in connection with the work, which should be removed daily.
- E. The Contractor shall wash all windows and other glass surfaces, leaving all areas free from putty marks, paint, etc.
- F. During and after installation, the Contractor shall furnish and maintain satisfactory protection to all equipment against injury by weather, flooding or breakage thereby permitting all work to be left in a new condition at the completion of the contract.

END OF SECTION 017821

## SECTION 017839 - PROJECT RECORDS, DRAWINGS

### PART 1 - GENERAL

#### 1.1 RECORD DRAWINGS

- A. The Contractor shall furnish an authentic set of marked-up drawings showing the installation insofar as the installation shall have differed from the Engineer's drawings. The drawings shall be delivered to the Engineer for making revisions to the original drawings immediately after final acceptance by the Owner.
- B. The Contractor shall furnish dimensioned drawings indicating locations of all underground mechanical and electrical facilities.

#### 1.2 SERVICE CONNECTION RECORDS

- A. The Contractor shall record the location of all service and property connections, new or existing, made to utilities constructed under this contract. Such records shall be turned over to the Owner upon completion of the work. The cost of making such records shall be included in the various unit or lump sum prices stipulated for the various items of the work.
- B. The location of each water connection as measured along the water line from the nearest fire hydrant. Photographs for water connection on both sides of the curb box shall be provided for each water service line replaced. If the private side service line is also replaced, an additional photograph showing the water service connection to the meter or shut-off valve on the private side shall be provided. Each photograph shall be georeferenced for inclusion into OWNER GIS documentation.

END OF SECTION 017839

## SECTION 024119 - REMOVAL OF STRUCTURES AND OBSTRUCTIONS

### PART 1 - GENERAL

#### 1.1 RELATED DOCUMENTS

- A. Drawings and general provisions of Contract, including General and Supplementary Conditions and Division 1 Specification sections, apply to work of this section.

#### 1.2 DESCRIPTION OF WORK

- A. This section includes removal of pavement, piping, and equipment necessary to clear space for new construction and/or to rehabilitate existing construction.

#### 1.3 REQUIREMENTS OF REGULATORY AGENCIES

- A. State and local code requirements shall control the disposal of debris resulting from the removal operation.

#### 1.4 PROTECTION

- A. Structures shall be removed in such a manner as not to damage portions of the existing structure which are to remain in place.

### PART 2 - PRODUCTS (NOT APPLICABLE)

### PART 3 - EXECUTION

#### 3.1 PAVEMENTS, SIDEWALKS, CURBING, SIMILAR STRUCTURES

- A. Removal of existing pavements, sidewalks, curbing, and similar structures shall end at an existing joint or a sawed joint. Sawed joints shall be straight, neat and free from chipped or damaged edges.
- B. For removal of reinforced or non-reinforced concrete, the minimum depth of saw cut shall be 3 in.
- C. For removal of reinforced concrete, the depth of saw cut shall be sufficient to cut the steel.
- D. If the concrete is coated with a bituminous surface or other material, the depth shall be sufficient to cut into the concrete, not including the coating depth, as specified above.

### 3.2 EXCAVATION OF RIGID PAVEMENT

- A. The Contractor shall excavate rigid pavement, consisting of concrete or concrete base with a wearing surface of brick or bituminous concrete, wherever such excavation is required for the purpose of this Contract.
- B. Pavement shall be excavated to neat lines and, only to widths required for trenches, for pipe laying and for construction of structures. Adequate provision shall be made to prevent settlement and breakage of pavement beyond the approved limits of excavation.
- C. All pavement broken or damaged beyond the limits above stated, or the approved extension thereof, shall be replaced by the Contractor at his expense.

### 3.3 CATCH BASINS, INLETS AND SIMILAR STRUCTURES

- A. Existing drainage structure designated by the Engineer to be removed shall be completely removed.
- B. Abandoned sewers shall be sealed and made watertight with approved masonry bulkheads.
- C. All castings salvaged from abandoned or removed drainage structures shall remain the property of the Owner and shall be cleaned and transported by the Contractor to a site designated by the Engineer or incorporated in the work where called for on the Drawings, scheduled, or so directed.

### 3.4 FENCE

- A. Where so required by the Drawings, existing fence shall be carefully dismantled and stored for reuse or for salvage by the Owner.
- B. Wood posts and other materials not considered salvageable by the Engineer shall be disposed of by the Contractor.
- C. The Contractor will be required to replace, at no cost to the Owner, material lost or damaged by negligence or by the use of improper methods.

### 3.5 EQUIPMENT REMOVAL

- A. All equipment, valves, piping, fittings, and miscellaneous steel structures that are removed shall remain the property of the Owner and shall be stored at site selected by the Owner. The Owner reserves the right to require the Contractor to dispose of certain unwanted portions of removed equipment and materials. The Owner shall have the right to reject any or all materials removed during construction, and the Contractor shall haul away and dispose of these materials in a suitable manner at no additional cost to the Owner.

### 3.6 DISPOSAL OF DEBRIS

- A. All debris resulting from demolition operations; i.e., broken concrete, masonry, pipe, miscellaneous metal, trees and brush, equipment, etc., shall be disposed of offsite.
- B. The Contractor shall police the hauling of debris to insure that all spillage from haul trucks is promptly and completely removed.

### 3.7 BACKFILLING

- A. All trenches, holes, and pits resulting from the removal and abandonment of any structure or obstruction shall be backfilled and compacted in accordance with the requirements of Section 312323.14.

END OF SECTION 024119



## SECTION 310000 - EARTHWORK

### PART 1 - GENERAL

#### 1.1 SUMMARY

- A. The Work covered by this Section shall include all excavation, trenching and related work for the construction of the designated structures and pipelines, backfill and other incidental work.
  
- B. The Work covered by this Section consists of:
  - 1. making all necessary excavations for the construction of all Work;
  - 2. preparing subgrade for foundations, slabs, walks, and pavements;
  - 3. doing all pumping, fluming, and dewatering necessary to keep the trenches and other excavation free from water;
  - 4. providing for uninterrupted flow of existing drains and sewers, and the disposal of water from any sources during the progress of the Work;
  - 5. supporting and protecting all trench walls, structures, pipes, conduits, culverts, posts, poles, wires, fences, buildings and other public and private property adjacent to the Work;
  - 6. removing and replacing existing sewers, culverts, pipelines and bulkheads where necessary;
  - 7. removing after completion of the Work all sheeting and shoring or other soil support materials not necessary to support the sides of trenches;
  - 8. removing and disposing all surplus excavated material;
  - 9. doing all backfilling and grading, of compacting backfill to limits specified or ordered by the Engineer;
  - 10. restoring all property damaged as a result of the Work involved in this Contract.
  
- C. The Work includes transporting surplus excavated materials not needed for backfill at the location where the excavation is made, to other parts of the Work where filling is required, and disposal of all types of surplus material off the site.

#### 1.2 RELATED DOCUMENTS AND SECTIONS

- A. Section 013319.01 – Field Testing Requirements
  
- B. Specific Project Requirements

#### 1.3 DEFINITIONS

- A. Backfill: Soil or granular materials used to fill an excavation.
  - 1. Initial Backfill: Backfill placed beside and over pipe in a trench, not including haunches to support sides of pipe.
  - 2. Final Backfill: Backfill placed over initial backfill to fill a trench.

- B. Bedding: Layer placed over the excavated subgrade in a trench before laying pipe.
- C. Borrow: Satisfactory soil imported for use as fill or backfill.
- D. Excavation: Removal and disposal of material encountered above subgrade or foundation elevations.
  - 1. Additional Excavation: Excavation below subgrade or foundation elevations as directed by Engineer.
  - 2. Trench: Narrow linear excavation
  - 3. Unauthorized Excavation: Excavation below subgrade or foundation elevations or beyond indicated dimensions without direction by Engineer. Unauthorized excavation, as well as remedial work directed by Engineer, shall be without additional compensation.
  - 4. Unclassified Excavation: Excavation to subgrade elevations regardless of the character of surface or subsurface conditions encountered, including rock, soil materials and obstructions.
- E. Embankment: A structure consisting of soil, granular material, shale, rock, or other approved material, constructed in layers to a predetermined elevation and cross-section.
- F. Granular materials: Natural aggregate, such as broken or crushed rock, gravel, or sand that can be readily incorporated into an 8-inch layer, and in which at least 65% by weight of the grains or particles are retained in a No. 200 sieve.
- G. Laboratory Dry Weight: The maximum laboratory dry weight shall be the weight provided by the laboratory when the sample is tested in accordance with ASTM D-698 Method A, C, or D.
- H. Optimum Moisture: The water content at which the maximum density is produced in a soil by a given compaction effort (ASTM D-698).
- I. Pavement Prism: Also referred to as the zone of influence. The area below a line drawn 45 degrees to the horizontal from the surface at the edge of pavement, sidewalk or curb.
- J. Pipe Embedment: The material placed in a trench surrounding a pipe or conduit consisting of the foundation, bedding, haunching, and initial backfill.
- K. Rock: Rock material in beds, ledges, unstratified masses, and conglomerate deposits and boulders of rock material one (1) cu. yd. or more in volume that when tested by an independent geotechnical testing agency, according to ASTM D 1586, exceeds a standard penetration resistance of 100 blows/2 inches.
- L. Shale: Laminated material, formed by the consolidation in nature of soil, having a finely stratified structure. For the purpose of these specifications, the following

bedrock types shall also be considered shale: mudstone, claystone, siltstone and hard clay.

- M. Soil: All earth materials, organic or inorganic, which have resulted from natural processes such as weathering, decay, and chemical reaction.
- N. Structures: Buildings, footings, foundations, retaining walls, slabs, tanks, curbs, pavement, mechanical and electrical appurtenances, or other man-made stationary features constructed above or below the ground surface.
- O. Subgrade: Surface or elevation remaining after completing excavation, or top surface of a fill or backfill immediately below subbase, drainage course, or topsoil materials.
- P. Utilities: On-site underground pipes, conduits, ducts, and cables, as well as underground services within buildings.

#### 1.4 SUBMITTALS

- A. Comply with all provisions of Section 013323, Shop Drawings and Submittals.
- B. Product Data: For the following:
  - 1. Source-locations of all materials shall be identified to the Engineer.
  - 2. Source quality laboratory test of all fill materials as required to show compliance with material specifications.
- C. Shop Drawings: Submit information for the following items:
  - 1. Excavation procedures (*prepared and stamped by a professional engineer, registered in the State of Ohio*).

#### 1.5 REFERENCES

- A. AASHTO M 43 Standard Specification for Size of Aggregate for Road and Bridge Construction
- B. ASTM C-150 Standard Specification for Portland Cement
- C. ASTM C-618 Standard Specification for Fly Ash and Raw or Calcined Natural Pozzolan for Use as a Mineral Admixture in Portland Cement Concrete
- D. ASTM D-698 Standard Test Methods for Moisture-Density Relations of Soils and Soil-Aggregate Mixtures Using 5.5-lb (2.49-kg) Rammer and 12-in. (305-mm) Drop
- E. ASTM D-1586 Standard Method for Penetration Test and Split-Barrel Sampling of Soils

- F. ASTM D-2487 Standard Test Method for Classification of Soils for Engineering Purposes
- G. ASTM D-2940 Standard Specification for Graded Aggregate Material for Bases or Subbases for Highways or Airports
- H. ASTM D-4253 Standard Test Method for Maximum Index Density and Unit Weight of Soils Using a Vibratory Table
- I. ASTM D-4254 Standard Test Method for Minimum Index Density and Unit Weight of Soils and Calculation of Relative Density
- J. State of Ohio - Department of Transportation - Construction and Material Specifications, Item 304, Aggregate Base.
- K. State of Ohio - Department of Transportation - Construction and Material Specifications, Material Detail 703.16, Suitable Materials for Embankment Construction.
- L. State of Ohio - Department of Transportation - Construction and Material Specifications, Material Detail 703.02.A.2, Fine Aggregate for Portland Cement Concrete

## 1.6 QUALITY ASSURANCE

- A. Qualifications
- B. Regulatory Requirements
- C. Certifications

## 1.7 PROJECT CONDITIONS

- A. Environmental Requirements
- B. Existing Conditions
  - 1. Existing ground elevations are not provided since the work is for intermittent excavation pits to perform the work. The Contractor shall satisfy himself by actual examination on the site of the Work, as to the existing elevations and contours, and the amount of work required.
- C. Existing Utilities on private or public lands
  - 1. Do not interrupt utilities serving facilities occupied by Owner or others unless permitted in writing by Engineer and then only after arranging to provide temporary utility services according to requirements indicated.
  - 2. Notify Engineer not less than two days in advance of proposed utility interruptions.

3. Do not proceed with utility interruptions without Engineer's written permission.
4. Contact utility-locator service for area where Project is located before excavating.

## 1.8 DELIVERY, STORAGE AND HANDLING

- A. Deliver products to the site, store and protect under provisions of Section 016600, Product Handling and Protection.
- B. Comply with all provisions of Section 013543, Environmental Protection.

## 1.9 SEQUENCING AND SCHEDULING

- A. Refer to 013319 for testing laboratory service scheduling.

## 1.10 PROHIBITION OF EXPLOSIVES

- A. The use of explosives is not permitted.

## 1.11 FIELD MEASUREMENTS

- A. The excavation pits and field marking of utilities may indicate locations where certain utilities, structures or facilities might possibly interfere with the installation of new improvements. The Contractor shall dig such exploratory test pits as may be necessary to determine the exact location and elevation of the indicated subsurface structure and shall make acceptable provision for their protection, support and maintenance in operation. The Engineer shall be provided advance notification when and where excavation for test pits will take place. The Contractor shall provide the Engineer a record of field locations of all listed utilities, structures or facilities a minimum of five (5) days prior to initiating construction of the project. Locations and elevations are to be provided by a Surveyor registered in the State of Ohio.

## PART 2 - PRODUCTS

### 2.1 GRANULAR PIPE EMBEDMENT

- A. Crushed gravel or crushed limestone meeting AASHTO M 43 gradation shall be used for bedding, haunching, and initial backfill as shown on the Drawings.

### 2.2 SAND PIPE EMBEDMENT

- A. Fine aggregate consisting of natural sand meeting the gradation requirements of ODOT Item 703.02.A.2 or shown on the Drawings. The material shall not be lumpy

or frozen, and shall be free from slag, cinders, ashes, rubbish, and other deleterious or objectionable material. Sand shall not contain a total of more than 10% by weight of loam and clay.

2.3 ONSITE BACKFILL

- A. Excavated soil material, capable of meeting specified compaction, and approved by the Engineer for use as backfill in designated locations.
- B. Based upon subsurface investigation, the Owner does not guarantee the onsite soils in its present state consists of the proper moisture content to achieve the specified compaction without drying or adding water.
- C. Unsuitable Backfill Material
  - 1. Onsite materials that are unsuitable for backfill, unless otherwise specifically shown in the Drawings, include rock or other materials greater than six (6) inches in their largest dimension, pavement, rubbish, debris, wood, metal, plastic, frozen earth, and the following soils classified per ASTM D-2487:

Symbol	Description
OL	Organic silts and organic silty clays of low plasticity
MH	Inorganic silts, micaceous or diatomaceous fine sands or silts, elastic silts
CH	Inorganic clays of high plasticity, fat clays
OH	Organic clays of medium to high plasticity
PT	Peat, muck, and other highly organic soils

2.4 SPECIAL BACKFILL MATERIAL (ODOT Item 304)

- A. Special backfill material shall meet the gradation requirements of ODOT Item 304 and shall consist of crushed gravel or crushed limestone in combination with natural sand or stone. The aggregate shall meet the following gradation requirements:

Sieve	Total Percent Passing
2 inch	100
1 inch	70-100
¾ inch	50-90
No. 4	30-60
No. 30	9-33
No. 200	0-15

2.5 LOW STRENGTH MORTAR BACKFILL

- A. Low Strength Mortar shall comply with ODOT Item 613.

- B. Submit test data that demonstrates that the proposed mix has a strength of 50 to 100 PSI at 28 days.
- C. Each load shall be tested with 3 cylinders for strength test broken at 3, 7, and 28 days until the Engineer is assured that the mix will be between 50 to 100 PSI at 28 days. Thereafter, one set of strength tests shall be taken every 50 CY.

It is intended that the sand be fine enough to stay in suspension in the mixture to the extent required for proper flow. The Engineer reserves the right to reject the sand if a flowable mixture cannot be produced.

- D. Mortar Mix Proportioning
  - 1. The initial trial mixture shall be as follows:

Quantity of Dry Materials per Cubic Yard

Cement	100 lbs.
Fly Ash	250 lbs.
Sand (SSD)*	2700 lbs.
Water	500 lbs.

\* saturated-surface dry

- 2. These quantities of materials are expected to yield approximately 1 cubic yard of mortar of the proper consistency. Adjustments of the proportions may be

### PART 3 - EXECUTION

#### 3.1 PROTECTION

- A. Excavation; Temporary Sheeting, Shoring, and Bracing
  - 1. All excavation shall be in accordance with the Occupation Safety and Health Administration (OSHA) regulations.
  - 2. The Contractor shall furnish and install adequate sheeting, shoring, and bracing to maintain safe working conditions, and to protect newly built work and all adjacent neighboring structures from damage by settlement.
  - 3. Bracing shall be arranged so as not to place a strain on portions of completed work until construction has proceeded enough to provide ample strength. Sheeting and bracing may be withdrawn and removed at the time of backfilling, but the Contractor shall be responsible for all damage to newly built work and adjacent and neighboring structures.
  - 4. All sheeting shall be removed unless specifically authorized in writing by the Engineer to be left in place.
- B. Construction Sheeting Left in Place
  - 1. The Contractor shall furnish, install, and leave in place construction sheeting and bracing when specified or when indicated or shown on the Drawings.

2. Any construction sheeting and bracing which the Contractor has placed to facilitate his work may be ordered in writing by the Engineer to be left in place. The right of the Engineer to order sheeting and bracing left in place shall not be construed as creating an obligation on his part to issue such orders. Failure of the Engineer to order sheeting and bracing left in place shall not relieve the Contractor of his responsibility under this Contract.

### 3.2 REPLACING, MOVING AND REPAIRING OF EXISTING UTILITIES

- A. The Contractor shall:
  1. replace, move, repair and maintain all utilities and all other structures encountered in the work
  2. coordinate and communicate with applicable utility companies
  3. repair all damage done to any of the said structures and appurtenances through his acts or neglect and shall keep them in repair during the life of this contract. The Contractor shall in all cases leave them in as good condition as they were previous to the commencement of the work and to the satisfaction of the Engineer.

### 3.3 DEWATERING

- A. Drainage and Removal of Water
  1. The Contractor shall dispose of water from the Work in a suitable manner without damage to adjacent property or structures.
  2. The Contractor shall, when ordered by the Engineer, construct tight bulkheads across trench and provide pumps suitable for the removal of any water which may be encountered or which may accumulate in the trenches. Unless otherwise provided for in the Contract Documents, drainage water will not be permitted to flow through the conduit.
  3. The trench shall be kept free from sewage and storm, surface, and subsurface water to at least 2 feet below the bottom of the excavation.
  4. Where open water courses, ditches, or drain pipes are encountered during the progress of the Work, the Contractor shall provide protection and securing of the continuous flow in such courses or drains and shall repair any damage that may be done to them.

### 3.4 EXCAVATION CLASSIFICATION

- A. All excavated materials are unclassified as defined in Article 1.3.

### 3.5 TRENCH EXCAVATION

- A. Excavation for trenches in which pipelines, sewers, and conduits are to be installed shall provide adequate space for workmen to space and joint pipe properly, but in



every case the trench shall be kept to a minimum width. The width of trench shall not exceed the limits shown on the Drawings or Referenced Details.

- B. Excavation shall be to the depth necessary for placing of granular bedding material under the pipe as shown on the Drawings. If over-excavation occurs, the trench bottom shall be filled to grade with compacted granular bedding material.
- C. Trenching operations shall not be performed beyond the distance that will be backfilled and compacted the same day.
- D. In general, backfilling shall begin as soon as the conduit is in approved condition to receive it and shall be carried to completion as rapidly as possible. New trenching shall not be started when earlier trenches need backfilling or the surfaces of streets or other areas need to be restored to a safe and proper condition.

### 3.6 EXCAVATION OF UNSUITABLE MATERIALS

- A. Unsuitable materials existing below the Contract bottom limits for excavation shall be removed as directed by the Engineer. Such excavation shall not exceed the vertical and lateral limits as prescribed by the Engineer.
- B. In utility trenches, the voids left by removal of unsuitable excavated material shall be filled with AASHTO M 43 No. 1 and No. 2 aggregate conforming to the material requirements of Article 2.1 of this Section.
- D. Removal of unsuitable excavated material and its replacement as directed will be paid on basis of Contract Conditions relative to Changes in Work unless specific unit prices have been established for excavation of unsuitable material.

### 3.7 DISPOSAL OF UNSUITABLE AND SURPLUS MATERIAL

- A. It shall be the responsibility of the Contractor to dispose of all surplus material that cannot be used in backfill or embankments at his expense outside the limits of the project. Unsuitable excavated material, including rock or large boulders, shall be disposed of outside the limits of the project.
- B. Surplus material may be wasted adjacent to or incorporated in the regular construction only when ordered in writing by the Engineer.

### 3.8 BACKFILL

- A. Pipelines, Sewers and Conduits
  1. All pipe shall have bedding extending the width of the trench with depth in conformance with the Drawings. The bedding material shall be thoroughly compacted by tamping until no further densification is possible.
  2. Pipe cover material shall be used for filling above the pipe bedding along the sides of the pipe and to a height of twelve (12) inches over the top of the

pipe. The pipe cover material shall be brought up evenly on both sides of the pipe to eliminate the possibility of lateral displacement of the pipe and shall be thoroughly compacted by tamping until no further densification is possible. Care shall be taken to spade the aggregate under the pipe haunch below the spring line.

3. All trenches and excavations shall be backfilled immediately after pipe is laid therein, unless otherwise directed by the Engineer.
  4. After the pipe cover has been placed and compacted around the pipe as specified above, the remainder of the trench may be backfilled by machine. The backfill material shall be deposited in eight (8) inch horizontal layers, and each layer shall be thoroughly compacted to the specified density by approved methods before a succeeding layer is placed. In no case will backfilling material from a bucket be allowed to fall directly on a pipe and in all cases the bucket must be lowered so that the shock of the falling earth will not cause damage.
  5. Puddling of sand bedding and pipe cover material is acceptable provided an acceptable method for removal of water is provided.
- C. Where any new, proposed, or future pavement, driveway, parking lot, curb, curb and gutter, or walk is to be placed over a backfilled area, Special Backfill material shall be used for any portion of the trench falling within the pavement prism.
- D. Where it is necessary to undercut or replace existing utility conduits and/or service lines, the excavation beneath such lines shall be backfilled the entire length with approved Granular Pipe Embedment Material compacted in place in eight (8) inch layers to the required density. The approved Granular Pipe Embedment Material shall extend outward from the spring line of the conduit a distance of two (2) feet on either side and thence downward at its natural slope.

### 3.9 LOW STRENGTH MORTAR BACKFILL

- A. Low strength mortar backfill shall be discharged from the mixer as recommended by the supplier and approved by the Engineer.
- B. Low strength mortar backfill may be placed in the trench in as few lifts as may be practical.
- D. Secure conduit or pipelines before placing low strength mortar backfill to prevent conduits and pipelines from floating during backfilling.
- E. For low strength mortar backfill placed against existing structures of unknown strength, backfill material shall be brought up uniformly in maximum 12 inch lifts and allowed to cure for a minimum of 24 hours or until it can carry a person's weight without leaving imprints before the next lift is placed.
- F. Low strength mortar backfill shall be brought up to subgrade elevation or the pavement prism, whichever may be applicable.

### 3.10 SUBGRADE

- A. All soil subgrade shall be prepared in accordance with this subsection.
- B. Drainage
  - 1. The surface of the subgrade shall be maintained in a smooth condition to prevent ponding of water after rains to insure the thorough drainage of the subgrade surface at all times.
- C. Unsuitable Subgrade
  - 1. Where unsuitable subgrade or subgrade not meeting the required bearing capacity is encountered in cuts, due to no fault or neglect of the Contractor, in which satisfactory stability cannot be obtained by moisture control and compaction, the unstable material shall be excavated to the depth required by the Engineer.
  - 2. Suitable material required for the embankment to replace the undercut will be paid on basis of Contract Conditions relative to changes in Work.
  - 3. Where soft subgrade in cuts is due to the failure of the Contractor to maintain adequate surface drainage as required in this article, or is due to any other fault or neglect of the Contractor, the unstable condition shall be corrected as outlined above at no expense to the Owner.

### 3.11 CONSTRUCTION WITH MOISTURE AND DENSITY CONTROL

- A. All backfill, except rock embankments, shall be constructed using moisture and density control. All subgrade, except rock and shale in cut sections, shall be constructed using moisture and density control.
- B. Backfill and subgrade material which does not contain sufficient moisture to be compacted in accordance with the requirements of Article 3.12 of this Section shall be sprinkled with water as directed by the Engineer to bring the moisture content to within the range of optimum plus or minus three (3) percent. Water shall be thoroughly incorporated into the material by means of discs or other approved equipment.
- C. Backfill and subgrade material containing excess moisture shall be dried, prior to installation, to a moisture content not greater than three (3) percentage points above optimum, except that for material within the moisture content range specified herein that displays pronounced elasticity or deformation under the action of loaded construction equipment, the moisture content shall be reduced to optimum or below if necessary to secure stability. For subgrade material, these requirements for maximum moisture shall apply at the time of compaction of the subgrade and also at the time of placing pavement or subbase. Drying of wet soil shall be expedited by the use of plows, discs, or by other approved methods when so ordered by the Engineer.

### 3.12 COMPACTION REQUIREMENTS

- A. The bottom of excavations upon which concrete foundations or structures are to be placed shall be compacted so as to obtain 100% of maximum dry density per ASTM D-698 in the top twelve (12) inches.
- B. The top twelve (12) inches of stripped original subgrade and final subgrade shall be compacted to not less than 100% of maximum dry density per ASTM D-698.
  - 1. Subgrade under new, proposed, or future pavement shall be compacted 18 inches beyond the edge of pavement, paved shoulders or paved medians.
- C. Compaction of subgrade for sidewalks (regardless of paving material) shall be 100% of maximum dry density per ASTM D-698 in the top six (6) inches.
- D. Compaction of non-paved areas shall be 90% of maximum dry density per ASTM D-698.
- E. Aggregate pipe embedment and aggregate backfill around structures shall be compacted to not less than 100% of maximum dry density per ASTM D-4253 and ASTM D-4254.
- F. Final backfill shall be compacted to not less than 100% of maximum dry density per ASTM D-698.

### 3.13 GRADING

- A. Uniformly grade areas to a smooth surface, free of irregular surface changes. Comply with compaction requirements and grade to cross sections, lines, and elevations indicated.
  - 1. Provide a smooth transition between adjacent existing grades and new grades.
  - 2. Cut out soft spots, fill low spots, and trim high spots to comply with required surface tolerances.
- B. Site Grading
  - 1. Slope grades to direct water away from buildings and to prevent ponding. Finish subgrades to required elevations within the following tolerances:
    - a. Lawn or unpaved areas shall be graded to plus or minus (*1 inch*) (*insert tolerance*).
    - b. Walks shall be graded to plus or minus (*1 inch*) (*insert tolerance*).
- C. Grading inside Building Lines
  - 1. Finish subgrade to a tolerance of 1/2 inch when tested with a 10-foot straightedge.

END OF SECTION 310000

## SECTION 312323.14 – COMPACTED GRANULAR BACKFILL

### PART 1 - GENERAL

#### 1.1 RELATED DOCUMENTS

- A. Drawings and general provisions of Contract, including General and Supplementary Conditions and Division-1 Specification sections, apply to work of this section.

#### 1.2 DESCRIPTION OF WORK

- A. The Contractor shall furnish, place and compact all the materials needed.

### PART 2 - PRODUCTS

#### 2.1 MATERIAL

- A. Aggregate shall be ODOT 304 crushed limestone. Crushed gravel or slag products are unacceptable.
- B. Contractor shall submit current test reports for the lot(s) of the material to be supplied.

### PART 3 - EXECUTION

#### 3.1 PLACING AND COMPACTING

- A. Compacted granular backfill shall be properly placed in layers sufficient to meet the compaction requirement of 100% of maximum laboratory dry density per ASTM D 698 throughout the entire layer and thoroughly compacted with mechanical compaction equipment with moisture adjustment as needed. Should after settlement occur, the Contractor must add and compact additional material, and he must maintain the backfill at the required finished grade or sub-grade until the project is satisfactorily completed and during the correction period.
- B. Approved mechanical compaction equipment shall be used for tamping backfill. Flooding, jetting or puddling of backfill will not be permitted.

END OF SECTION 312323.14

## SECTION 320190.33 – TREE AND SHRUB PRESERVATION

### PART 1 - GENERAL

#### 1.1 RELATED DOCUMENTS

- A. Drawings and general provisions of Contract, including General and Supplementary Conditions and Division-1 Specification sections, apply to work of this section.

#### 1.2 DESCRIPTION OF WORK

- A. Furnish all labor, equipment and incidentals required to protect existing vegetation areas not to be disturbed.

### PART 2 - PRODUCTS

#### 2.1 MATERIALS

- A. Marking Tape
  - 1. Red and yellow nylon or approved equal.
- B. Fencing or other protective devices as approved by Engineer.

### PART 3 - EXECUTION

#### 3.1 PROTECTION

- A. Marking and Identification
  - 1. The extent of the area to be cleared and grubbed will be marked in the field by stakes and red fiberglass or nylon tape. Individual trees or shrubs to be removed from a location where most of the vegetation is to remain will also be marked by red tape. Any vegetation to remain within a larger area identified to be cleared and grubbed will be marked by yellow tape.

#### 3.2 PROTECTION AND CARE OF TREES AND SHRUBS

- A. Protect all other trees and shrubs from defacement, injury and destruction. Preserve trees within the right-of-way or construction area that are so delineated on the Drawings or are marked in the field.

- B. During work operations, protect the trunk, foliage, and root system of all trees to be saved with boards or other guards placed as required to prevent damage, injury and defacement. Do not pile excavated material adjacent to the base of any trees. Do not allow runoff to accumulate around bases of trees. Do not fasten or attach ropes, cable or guy wires to trees without permission of the Engineer. Provide climbing ropes during trimming.
- C. All such trees, shrubs, and plants shall be carefully trimmed and protected from scarring, barking, or other injury during construction operations. All cuts and scars on trees shall be painted and treated with an approved wound dressing especially prepared for tree surgery, as directed by the Engineer.

### 3.3 TREE PRUNING

#### A. Pruning Existing Trees

1. Contractor shall prune all existing trees tagged or designated by the Engineer to remain.
2. Remove all dead, damaged and diseased wood completely. Do not leave stubs as it is unsightly and provides an entry point for disease spores. Also, remove crossed, girdling, or misplaced branches with care not to spoil the natural habit of the tree or shrub. The branch should always be removed flush with the trunk or parent branch while exposing the smallest area of cut surface possible without leaving an unnecessary stub.
3. Use the undercut method for the removal of all branches greater than 1/2". If necessary, cut a long, heavy branch into several convenient, manageable lengths to reduce the weight in easy stages. The undercut prevents any possible tearing of the bark below the branch. All wounds shall be carefully pared over with a sharp knife and covered with wound paint, approved by the Engineer, within 24 hours.
4. Trees and shrubs shall also be pruned in order to restore typical branching habits for that particular species, by trained and experience personnel.
5. Prune existing mature trees in late autumn or early winter, particularly for those trees that produce large quantities of sap.

### 3.4 DISPOSAL OF MATERIALS

- A. All tree trunks, limbs, roots, stumps, brush, foliage and other vegetation shall become the property of the Contractor and shall be removed and disposed of by him off the project site in a manner complying with applicable local, State and Federal regulations. No burning will be allowed.

END OF SECTION 320190.33

## SECTION 321000 - PAVEMENT REPLACEMENT

### PART 1 - GENERAL

#### 1.1 RELATED DOCUMENTS

- A. Drawings and general provisions of Contract, including General and Supplementary Conditions and Division-1 Specification sections, apply to work of this section.

#### 1.2 DESCRIPTION OF WORK

- A. The Contractor shall furnish all of the equipment, labor and materials necessary to install, replace, and/or restore existing pavement structures together with their respective appurtenances as shown on the plans and as specified herein. This work shall include all of the subgrade preparation, subbase, base, intermediate pavement course(s), and finish pavement courses together with curbing, guttering, tack and/or prime coating, sealing and other pertinent work as necessary to meet the conditions of this contract.

#### 1.3 QUALITY ASSURANCE

- A. In addition to requirements of these specifications, comply with manufacturer's instructions and recommendations for work.

#### 1.4 REPAIR OR REPLACEMENT WORK

- A. For the repair and/or replacement of all existing pavement structures and their respective appurtenances that are removed and destroyed or otherwise damaged by the Contractor in the course of his performance of the work required under this contract, the Contractor shall furnish all equipment, labor, and materials as necessary to properly restore to a condition equal to that at his entry, and to the satisfaction of the Engineer, the Ohio Department of Transportation, the County Engineer, City Engineer, all cinder, slag, gravel, water-bound macadam, bituminous macadam, asphalt and brick or concrete driveways, curbs, sidewalks and roadways in strict accordance with the drawings and as specified herein.
- B. In general, this item will include concrete, steel reinforcement, brick, stone, slag, cinders, gravel, asphalt and other bituminous materials and curbs, gutters, driveway culverts, road and curb drains and the demolition, excavation and removal of existing driveways, sidewalks and roadways.
- C. No trench, pot-hole or other excavation shall be left open overnight. When backfilling has been completed, but the pavement will not be restored by end of the work week (Fridays), provide cold-patch or other acceptable means of capping the granular base for maintenance purposes, so stone will not be knocked out of the holes and scattered. Cost of this fill material will be included in other costs for the work, and no separate pay item will be made for this work.



## 1.5 REFERENCE TO OTHER PARTS

- A. Other sections of these specifications shall apply, as and where applicable to this section and such sections will be the same as though they were included in this section.
- B. For all old work where pavement is being repaired and/or replaced as a result of damages occurring thereto during the course of the work of this contract, all clearing and grubbing, removal and storage of topsoil, excavation and/or placing of compacted fill and granular backfill, shall be done as required under other parts of these specifications.

## PART 2 - PRODUCTS

### 2.1 MATERIALS

- A. Generally, for all repair and replacement work, all new materials shall match the existing and adjoining work in both composition and quality unless otherwise ordered, specified herein, and/or shown on the drawings. In any stone driveway or roadway, the material used for stone fill shall conform to the existing material.
- B. All concrete material shall be MS concrete per ODOT specs.

## PART 3 - EXECUTION

### 3.1 CONSTRUCTION

- A. All pavement work shall be done in strict accordance with the specifications of the governmental body concerned and the latest ODOT specifications as applicable or at the direction of the Engineer.
- B. All pavements disturbed by the Contractor's operations shall be relaid to the thickness of the adjoining pavement and, in all cases, the restoring of pavements, shall apply both to foundation courses and to the wearing surface.
- C. Should cracks or settlements appear in adjoining pavements, the paving shall be removed to the extent necessary to secure firm and undisturbed bearing and shall be replaced in a satisfactory manner.
- D. No permanent pavement shall be installed, repaired, and/or restored unless, or until, in the opinion of the Engineer, the condition of the backfill is such as to properly support the pavement.
- E. Where new or replacement concrete pavement or base is placed adjacent to existing concrete pavement or base, contraction joints shall be provided in the new or replacement pavement so as to form a continuous joint with that in the existing pavement.

### 3.2 ROADWAY SUBGRADE

- A. The entire area to be occupied by the roadways and parking areas shall be cleared, topsoil removed and stored, and the excavation or compacted fill made as required and brought to the proper cross-sections. Pipe trenches and other excavations shall be backfilled as required, and thoroughly compacted within the limits of the roadways or parking areas.
- B. After the surface of the subgrade has been properly shaped and before any stone or slag is placed, the entire subgrade shall be thoroughly rolled and compacted to a depth of 12 inches under this section. Rolling shall be done with an approved type of self-propelled roller, weighing not less than ten (10) tons. All hollows and depressions which develop during the rolling shall be filled with acceptable materials, and the subgrade rerolled. The process of filling and rolling shall be repeated until no depressions develop, and the entire subgrade has been brought to a uniform condition of stability.
- C. All places which, in the opinion of the Engineer cannot be properly rolled, shall be tamped with handheld mechanically or pneumatically powered tampers.
- D. In making the compacted fill and in doing the final subgrade rolling, the Contractor shall see that the material to be compacted and/or rolled has the proper moisture content to secure maximum compaction. When, in the opinion of the Engineer, the material is too wet, the compacting shall be delayed until the material has dried sufficiently. When, in the opinion of the Engineer, the material is too dry, the material shall be sprinkled with water in an amount to secure the proper moisture content.

END OF SECTION 321000

## SECTION 321216 - ASPHALT CONCRETE PAVING AND MATERIALS

### SECTION 1 - MATERIALS

- 1.1 The asphalt concrete mixture and installation thereof shall meet Ohio Department of Transportation (ODOT) Specifications except as modified in these specifications.
- 1.2 In the ODOT Specifications substitute "Engineer" for "Department" (except as stated below in reference to ODOT 403 for Department VA testing and acceptance).
- 1.3 No steel slag shall be used as coarse or fine aggregate for any asphalt concrete.
- 1.4 All asphalt cement utilized on this project shall meet AASHTO Provisional Standard MP1 or any superseding AASHTO specification for performance graded asphalt cement binder in conformance with PG 64-22.
- 1.5 The following exceptions shall be made
  - A. The coarse aggregate material shall be only limestone
  - B. No Recycled Asphalt Product (R.A.P.) will be permitted
- 1.6 Except where designated otherwise in the plans or specifications all asphalt concrete mixes shall be designed for medium traffic volumes. Where light or heavy traffic pavements are designated in the plan, the contractor shall use an asphalt concrete mix designed for such traffic conditions.
- 1.7 Acceptance of the mixture will be based upon the certification that the mixture was produced according to the approved JMF within the production control and composition tolerances of the specifications. The Contractor shall hire and pay for an independent testing lab approved by the Engineer to perform all sampling, testing, monitoring, analysis and certification required by the Laboratory, Monitoring Team or Department in ODOT 403 and 441. All work by the independent laboratory shall be performed by personnel with ODOT Level II Bituminous Concrete certification.
- 1.8 ODOT 401.20 - "Asphalt Binder Price Adjustment" shall not apply to this contract.
- 1.9 Monument box and valve box risers shall be East Jordan Iron Works No. 8626, No. 8631, or approved equal. The Contractor shall follow the manufacturer's recommended installation procedure. New manhole frames and grate or frame and cover shall be EJIW 1710.
- 1.10 Brick used for manhole, catch basin, or inlet basin castings adjusted to grade under ODOT 611.10 Method D.1. shall be red shale or clay sewer brick meeting the requirements of ASTM C32 sewer brick, grade SM.
- 1.11 Risers used for manhole castings adjusted to grade under ODOT 611.10 Method D.2. shall be manufactured by Manhole Systems, Model MS-101TB, or approved equal.
- 1.12 All inlets and manholes shall be adjusted to grade after installation of the intermediate course(s), if any and prior to installation of the surface course.

- 1.13 All materials delivered to this project must have been weighed on a platform scale with electronic imprinter to show gross, tare, and net weights. No payment will be made for materials which are not correctly weighed as necessary. Material weight shall not exceed the current legal allowable limit.
- 1.14 Unless specified elsewhere in the specifications, material for berms shall be limestone only. Recycled concrete and asphalt concrete will not be permitted.

## SECTION 2 - PAVING EQUIPMENT

- 2.1 All spreading equipment shall be self propelled. The Contractor shall identify the make and model of the paving machine that will be used for the intermediate and surface courses for approval prior to the pre-construction meeting.
- 2.2 All equipment, tools, and machines used in the performance of this work shall be maintained in satisfactory working order at all times. The Contractor shall be prepared to furnish proof of certification that all equipment to be used on the project has been calibrated within the past six (6) months.

## SECTION 3 - GENERAL - PAVING

- 3.1 All paving shall be done on a single-lane basis.
- 3.2 If traffic loop detectors are encountered and broken, the Contractor is to repair as per local specifications. The cost for this work will be paid under the loop detector replacement bid item, if any; at negotiated unit prices; or by time and materials as directed by the Engineer.
- 3.3 Tack Coat, Item 407, shall be applied at the rate of from 0.05 to 0.15 gallons per square yard as appropriate for the surface conditions with sand cover if required.
- 3.4 Asphalt driveway aprons shall be matched to new pavement with 24" transition sections or as shown on the drawings or required by the Engineer. The Contractor shall install apron wedge as required in the detailed drawings.
- 3.5 Unless otherwise shown on the drawings, jointing of new to existing pavement shall be by milled butt joints six (6) feet in width (or as shown on the plans) from edge of pavement to edge of pavement. Depth of this milled area shall equal the total of subsequent intermediate course and surface course as specified.
- 3.6 One (1) copy of each hauled/weighed material truck load ticket (plant ticket) for materials incorporated in this project shall be provided to the project representative daily. All bulk materials delivered to this project must have been weighed on a platform scale with electronic imprinter to show gross, tar and net weights. No payment will be made for materials which are not correctly weighed as necessary. Material weight shall not exceed the current legal allowable limit. If a partial load is used, the Contractor's foreman and the project representative shall confer and come to an agreement as to what portion of the

product was used. The percent of material of this load, as reported by the project representative, is what shall be recorded as utilized.

- 3.7 For variable depth courses where tonnage tickets are used for determining quantities for payment, the conversion to cubic yards shall be number of tons verified and approved by the Engineer divided by 2.00 regardless of the actual density of the mix.
- 3.8 Positive drainage is to exist subsequent to the completion of the surface course. The Contractor shall take any necessary measures to assure positive drainage of the surface course. It shall be the responsibility of the Contractor to repair any low/puddled areas at his own cost by milling out the affected areas to a minimum depth equal to the nominal depth of the course being repaired and replacing with the specified asphalt concrete to grades that will correct the drainage problem.
- 3.9 Surface tolerances for all completed surface courses shall be as noted in ODOT 401.19. This tolerance shall apply regardless of whether or not an intermediate course is installed.
- 3.10 At the direction of the Engineer, periodic weight checks of asphalt concrete in loaded trucks shall be made by the Contractor and verified by the Engineer.
- 3.11 All quality control testing data performed on material incorporated into this project shall be forwarded to the Engineer for review as soon as it is available.
- 3.12 Quantity verification (but not necessarily payment quantity) for all asphalt concrete incorporated into the work shall be by weight tickets as produced by the plant or supplier or other means approved by the Engineer. Tack coat shall be verified by a ticket filled out and signed by the Contractor's tack truck driver based on weights taken or observations of level indicators. All verification tickets are required to be submitted to the Engineer on the day the material is incorporated into the work; however, the Engineer may, at his sole discretion, accept verification tickets for any items up to seven (7) calendar days subsequent to the work being performed. **After that date additional verification tickets for material will not be accepted for consideration of payment.**
- 3.13 No work is to be performed without the presence of the Engineer or his designated Project Representative. Forty-eight (48) hour advance notice of work shall be given to the Engineer and Owner by the Contractor.
- 3.14 All edges of surface courses abutting curbs or other appurtenances shall be sealed with hot AC-20.
- 3.15 The asphalt concrete, intermediate or surface course work will conform to ODOT Items 448-1 – Intermediate and Surfaces Courses and 448-2 – Intermediate Course. The paving foreman, at the Engineer's request, will be required to correctly calculate the asphalt concrete "yield." "Yield" is defined as the rate of material used, in cubic yards, in proportion to the area paved. The Contractor must be aware if he is under or over plan quantities for the area in question.

END OF SECTION 321216

## SECTION 321613.13 - CONCRETE CURBS

### PART 1 - GENERAL

#### 1.1 RELATED DOCUMENTS

- A. Drawings and general provisions of Contract, including General and Supplementary Conditions and Division-1 Specification sections, apply to work of this section.

#### 1.2 DESCRIPTION OF WORK

- A. Under this section the Contractor shall furnish and construct curbing of various, designated types as encountered during the project.
- B. This section includes preparation of the base and/or subgrade construction of curbs, other work and materials incidental to the construction of curbing.

#### 1.3 OWNER'S STANDARDS AND SPECIFICATIONS

- A. Items preceded by ODOT shall refer to the latest edition of the State of Ohio, Department of Transportation, Construction and Material Specifications.

### PART 2 - PRODUCTS

#### 2.1 CURBING

- A. Materials for curbing shall meet the applicable requirements of ODOT Item 609.

### PART 3 - EXECUTION

#### 3.1 INSTALLATION

- A. All soil subgrade under curbs shall be compacted in accordance with Section 310000.
- B. All construction for curbing shall be in accordance with ODOT Item 609 for the type called for on the Drawings.

END OF SECTION 321613.13

## SECTION 321623 - CONCRETE WALKS

### PART 1 - GENERAL

#### 1.1 RELATED DOCUMENTS

- A. Drawings and general provisions of Contract, including General and Supplementary Conditions and Division-1 Specification sections, apply to work of this section.

#### 1.2 DESCRIPTION OF WORK

- A. Under this section the Contractor shall furnish and construct sidewalks and stairs as shown or scheduled on the Drawings, specified or directed.
- B. This section includes preparation of the base and/or subgrade construction of walks, adjustment of manhole castings and valve boxes to conform to new elevations and other work and materials incidental to the construction of walks and stairs.

#### 1.3 OWNER'S STANDARDS AND SPECIFICATIONS

- A. Items preceded by ODOT shall refer to the latest edition of the State of Ohio, Department of Transportation, Construction and Material Specifications.

### PART 2 - PRODUCTS

#### 2.1 WALKS

- A. Materials for walks shall meet the applicable requirements of ODOT Item 608.

### PART 3 - EXECUTION

#### 3.1 INSTALLATION

- A. All soil subgrade under walks shall be compacted in accordance with Section 312323.14.
- B. All service boxes, manholes and inlet tops shall be set to the required grades.
- C. All construction for walks and stairs shall be in accordance with ODOT Item 608 for the type called for on the Drawings.
- D. Minimum thickness of concrete walks shall be 4 inches.

END OF SECTION 321623

## SECTION 329219 - SEEDING

### PART 1 - GENERAL

#### 1.1 SUMMARY

- A. Installation of seeded areas shall be to the extent disturbed by Contractor and shall include supplying all seed, topsoil, soil conditioning materials, mulching materials and watering, and the incorporation of these materials into the work as specified.
- B. The Contractor shall place topsoil at the depths specified in those areas requiring seeding. Topsoil shall be furnished by the Contractor.

#### 1.2 SUBMITTALS

- A. Product Data: For the following:
  - 1. Provide copies of soils tests for both new topsoil (provided) and onsite topsoil for review and approval. This applies to all areas that require seeding, including reconditioned areas.
  - 2. Provide location of properties from which topsoil is to be obtained, names and addresses of owners, depth to be stripped, and crops grown in the past 2 years.
  - 3. Provide the name of the seed supplier, name and phone number, list of the seed, including varieties of seed, labels, and an analysis of the seed for review, 4 weeks prior to the start of seeding.
  - 4. Provide soil amendments information based on soils test requirements.
  - 5. Hydroseed mixture, mulch and application rates prior to performing the work.

#### 1.3 QUALITY ASSURANCE

- A. Any subcontracted restoration work shall be performed by a qualified firm specializing in landscape work.
- B. The Contractor shall have a soils test done at there expense and analyzed by a state approved testing agency. Soil tests shall be done on both the topsoil stockpiled from the site and new topsoil brought to the site. A minimum of two (2) tests shall be done. The tests shall include percent organic matter, pH, Buffer pH, Phosphorus, Exchangeable Potassium, Calcium, Magnesium, Cation Exchange Capacity and Percent Base Saturation with recommendations for nitrogen, phosphate, potash, magnesium and lime based on plant type and use.
- C. Seed: All seed specified shall meet O.D.O.T. specifications as to the percentage purity, weed seed, and germination. All seed shall be approved by the State of Ohio, Department of Agriculture, Division of Plant Industry, and shall meet the requirements of these specifications.



- D. Packaged Materials: Deliver packaged materials in containers showing weight, analysis, and name of manufacturer. Protect materials from deterioration during delivery, and while stored at site.

#### 1.4 PROJECT CONDITIONS

- A. Utilities: Determine location of underground utilities and perform work in a manner which will avoid possible damage. Hand excavate, as required. Maintain grade stakes set by others until removal is mutually agreed upon by parties concerned.
- B. Excavation: When conditions detrimental to plant growth are encountered, such as rubble fill, adverse drainage conditions, or obstructions, such conditions shall be rectified by the Contractor before planting, with approval from the Owner's Representative.
- C. Soil Stabilization: The Contractor shall provide permanent or temporary soil stabilization to denuded areas within fifteen (15) days after final grade is reached on any portion of the site. Any such area which will not be regraded for longer than fifteen (15) days shall also be stabilized. Soil stabilization includes any measures which protect the soil from the erosive forces of raindrop impact and flowing water. Applications include seeding and/or mulching, or the use of other erosion control measures as directed by the Owner's Representative. If necessary, the Contractor shall coordinate soil stabilization practices with the local Soil and Water Conservation District.
- D. Spring-sown work shall be installed between April 1st and May 30th and Fall-sown work shall be installed between September 1st and October 15th. No permanent seeding shall take place between May 30th and September 1st and between October 15th and April 1st. The dates for seeding may be changed at the discretion of the Owner's Representative.

### PART 2 - PRODUCTS

#### 2.1 TOPSOIL

- A. Topsoil shall be furnished by the Contractor. Stockpiled material, if any, shall be utilized prior to obtaining additional topsoil.
- B. All topsoil shall conform to the U.S. Department of Agriculture soil texturing triangle and shall contain between 3% to 8% organic matter. Topsoil shall be loamy and not consist of more than 38% clay. New topsoil shall be screened to remove clay lumps, brush, weeds, litter, roots, stumps, stones larger than ½" in any dimension and any other extraneous or toxic matter harmful to plant growth.

New topsoil shall be obtained only from naturally well drained sites where topsoil occurs in a depth of not less than 4". Do not obtain from bogs or marshes.

- C. Soil amendments shall be added according to the soils test requirements. Amendments can include, but are not limited to fertilizer, lime, compost, sand, and organic matter. Organic matter shall consist of composted leaves or other approved material.

2.2 SEED

- A. Seed shall be vendor mixed, delivered in original bags and shall be proportioned as follows:

<u>Common Name</u>	<u>Proportion by Weight</u>
Kentucky Bluegrass	40%
Penn Lawn Fescue	40%
Perennial Rye	20%

2.3 MULCH

- A. Mulch shall be clean straw free of seed and weed seed.
  - 1. Anchoring for mulch shall be an ODOT specified SS-1 at 60 gal./ton non-toxic tackifier such as Hydro-stik, or equal, or by securing with a photo degradable netting.
- B. If hydroseeding is used, wood fiber mulching material shall be used and shall consist of virgin wood fibers manufactured expressly from whole wood chips and shall conform to the following specifications.

- Moisture content	10.0% ± 3.0%
- Organic content	99.2% ± 0.8% O.D. Basis
- pH	4.8 ± 0.5
- Water holding capacity, minimum (grams of water per 100 grams of fiber)	1,000

Wood fiber mulching material shall be processed in such a manner as to contain no growth or germination inhibiting factors, and must contain a biodegradable green dye to aid in visual metering during application.

PART 3 - EXECUTION

3.1 PREPARATION - GENERAL

- A. Rough grading to a depth necessary to accept the specified thickness of topsoil must be approved prior to placing topsoil.
- B. Loosen subgrade, remove any stones greater than ½” in any dimension. Remove sticks, roots, rubbish, and other extraneous matter.
- C. Spread topsoil to a minimum depth of 4 inches, to meet lines, grades, and elevations shown on plan, after light rolling and natural settlement. Remove sticks, roots, rubbish, stones greater than 1/2" in any dimension, and other extraneous matter. Topsoil shall be tilled thoroughly by plowing, disking, harrowing, or other approved methods. Add specified soil amendments and mix thoroughly into the topsoil.

- D. Preparation of Unchanged Grades: Where seed is to be planted in areas that have not been altered or disturbed by excavating, grading, or stripping operations, prepare soil for planting as follows: Till to a depth of not less than 6 inches. Apply soil amendments and initial fertilizers as specified. Remove high areas and fill in depressions. Till soil to a homogenous mixture of fine texture, free of lumps, clods, stones, roots and other extraneous matter. Soils test requirements apply here as well.
1. Prior to preparation of unchanged areas, remove existing grass, vegetation and turf. Dispose of such material outside of project limits. Do not turn existing vegetation over into soil being prepared for seed.  
  
If necessary, supply and install topsoil in areas where there is no topsoil left after vegetation has been removed.
  2. Apply specified soil amendments at rates specified in the soils test and thoroughly mix into upper 2 inches of topsoil. Add topsoil if existing grade has less than 4" of topsoil. Delay application of amendments if planting will not follow within two (2) days.
- E. Fine grade areas to smooth, even surface with loose, uniformly fine texture. Roll, rake, and drag lawn areas, remove ridges and fill depressions, as required to meet finish grades. Remove sticks, roots, rubbish, stones greater than 1/2" in any dimension, and other extraneous matter. Limit fine grading to areas which can be planted immediately after grading.
- F. Moisten prepared areas before planting if soil is dry. Water thoroughly and allow surface moisture to dry before planting lawns. Do not create a muddy soil condition.
- G. Restore areas to specified condition, if eroded or otherwise disturbed, after fine grading and prior to planting.

### 3.2 SEEDING

- A. Do not use wet seed or seed that is moldy or otherwise damaged in transit or storage. Seed shall not be sown when the ground is frozen, muddy, or when weather conditions prevent proper soil preparation, interference with sowing and/or proper incorporation of seed into the soil.
- B. Sow seed using a spreader or hydroseeder. Do not seed when wind velocity exceeds 5 miles per hour. Distribute seed evenly over entire area by sowing 3 lbs. per 1000 S.F. at right angles to each other. Total amount to equal a minimum of 6 lbs. per 1000 S.F.
- C. For seed sown with a spreader, mulch shall be spread uniformly to form a continuous blanket at a rate of 100 lbs. per 1,000 S.F. Mulch shall be 1 1/2" loose measurement over seeded areas and shall be anchored.

- D. Contractor has the option to hydroseed large lawn areas, using equipment specifically designed for such application. The rate of application of wood fiber mulching materials is 40 lbs./1,000 S.F. Contractor shall not hydroseed within close proximity to buildings and structures, or when unfavorable wind conditions may blow the hydroseed material onto the structure. Contractor shall clean all areas not to be seeded of overspray.
- E. The seeded area shall be watered, as soon as the seed is applied, at the rate of 120 gallons per 1000 square feet. The water shall be applied by means of a hydroseeder or a water tank under pressure with a nozzle that will produce a spray that will not dislodge the mulching material. Cost of this watering shall be included in the cost of seeding and mulching.

### 3.3 DORMANT SEEDING METHOD

- A. Seeding shall not take place from October 15 through November 20. During this period prepare the seed bed, add the required amounts of lime and fertilizer, and other amendments, then mulch and anchor.
- B. From November 20 through April 1, when soil conditions permit, prepare the seed bed, lime and fertilize, apply the selected seed mixture, mulch, and anchor. Increase the seeding rate by 50 percent.

### 3.4 RECONDITIONING EXISTING LAWNS

- A. A soils test shall be required for existing lawns prior to any reconditioning.
- B. Recondition all existing lawn areas damaged by Contractor's operations including storage of materials and equipment and movement of vehicles. Also recondition existing lawn areas where minor regrading is required.
- C. Provide soil amendments as called for in the soils test.
- D. Provide new topsoil, as required, to fill low spots and meet new finish grades.
- E. Cultivate bare and compacted areas according to the topsoil specifications.
- F. Remove diseased and unsatisfactory lawn areas; do not bury into soil. Remove topsoil containing foreign materials resulting from the Contractor's operations, including oil drippings, stone, gravel, and other loose building materials.
- G. All work shall be the same as for new seeding.
- H. Water newly planted seed areas. Maintenance of reconditioned lawns shall be the same as maintenance of new lawns.

### 3.5 ESTABLISHMENT

- A. Maintain work areas as long as necessary to establish a uniformly close stand of grass over the entire lawn area. A uniformly close stand of grass is defined as the seeded areas having 90%+ coverage of grass at 60 days after seeding. 90%+ coverage is defined as very little or no dirt showing when seeded area is viewed from directly overhead.
  
- B. Maintain lawns by watering, fertilizing, weeding, mowing, trimming, and other operations such as rolling, regrading and replanting as required to establish a smooth acceptable lawn.
  - 1. Mowing
    - a. Mow lawn areas during the period of maintenance to a height of 2 inches whenever the height of the grass becomes 3 inches. A minimum of 3 mowings is required during the period of maintenance.
  - 2. Refertilizing
    - a. Distribute fertilizer on the seeded area between August 15 and October 15, during the period when grass is dry, and in accordance with the manufacturer's recommendations. The fertilizer shall be as specified in the soils test.
  - 3. Reseeding
    - a. Reseed with the seed specified for the original seeding, at the rate of 4 lbs. per 1,000 S.F. in a manner which will cause minimum disturbance to the existing stand of grass and at an angle of not less than 15 degrees from the direction of rows of prior seeding.
  - 4. Watering
    - a. The Contractor shall keep all work areas watered daily to achieve satisfactory growth. Water shall be applied at a rate of 120 gallons per 1,000 square feet. If water is listed as a pay item, it shall be separately paid for based on the actual amount of water used, measured in thousands of gallons.
  - 5. Any mulching which has been displaced shall be repaired immediately. Any seed work which has been disturbed or damaged from the displacement of mulch shall be repaired prior to remulching.

### 3.6 INSPECTION AND ACCEPTANCE

- A. When seeding work is complete and an acceptable stand of growth is attained, the Contractor shall request the Owner's Representative to make an inspection to determine final acceptance.
  
- B. Acceptance shall be based upon achieving a vigorous uniformly stand of the specified grasses. If some areas are satisfactory and some are not, acceptance may be made in blocks, provided they are definable or bounded by readily identified permanent surfaces, structures, or other reference means. Partial acceptance decisions may be made by the Owner's Representative. Excessive fragmentation into accepted and unaccepted areas shall not be allowed. Unaccepted areas shall be maintained by the Contractor until acceptable.

- C. No payment shall be made until areas are accepted.
- D. All seeded areas shall be guaranteed for one full growing season to commence upon final acceptance of the areas.

END OF SECTION 329219

## SECTION 330533.23 - HIGH DENSITY POLYETHYLENE (HDPE) PIPE AND FITTINGS

### PART 1 - GENERAL

#### 1.1 DESCRIPTION OF WORK

- A. The work covered by this Section includes but is not limited to Ductile Iron Pipe Size (DIPS) high-density polyethylene pipe intended for the transportation of potable water.
- B. It is the intent of this Contract that the final installation be complete in all respects and the Contractor shall be responsible for minor or specific details; coordination with trades, equipment manufacturing, installation and manufacturers start-up representatives; and any necessary special construction not specifically included in the Drawings or Specifications.

#### 1.2 RELATED DOCUMENTS

- A. Drawings and general provisions of Contract, including General Supplementary Conditions and Division-1 Specifications sections apply to work of this section.

#### 1.3 QUALITY ASSURANCE

- A. The named equipment in addition to the detailed specifications, establishes the minimum acceptable standards of material and workmanship. In addition to requirements of these Specifications, all work performed shall be in accordance with approved trade practices and manufacturers recommendations. All equipment shall perform as specified and accessories shall be provided as required for satisfactory operation.
- B. The Contractor shall coordinate and verify that the material furnished meets the Specification, intentions and design criteria prior to equipment submittals and shipment from the manufacturer to the project site.
- C. Material References:

<u>Reference</u>	<u>Title</u>
1. AWWA C906	Polyethylene (PE) pressure Pipe & Fittings 4-inch through 63-inch for water dist.
2. ASTM D3261	Butt Heat Fusion PE Fittings for PE Pipe and Tubing
3. ASTM D3350	Standard Specification for PE Pipe & Fittings Materials
4. ASTM D1238	Standard Test Method for Flow Rates of Thermoplastics by Extrusion Plastometer
5. ASTM D1505	Density of Plastics
6. ASTM D2837	Hydrostatic Design Basis
7. NSF Std. #14	Plastic Piping Components &Y Related Materials
8. ASTM F714	Standard Specification for Polyethylene (PE) Plastic Pipe (SDR-PR) Based on Outside Diameter

- |     |             |  |
|-----|-------------|--|
| 9.  | ASTM F905   | Standard Practice for Qualification of Polyethylene Saddle-Fused Joints  |
| 10. | ASTM F 1055 | Standard Specification for Electrofusion Type Polyethylene Fittings for Outside Diameter Controlled Polyethylene Pipe and Tubing |

#### 1.4 SUBMITTALS

- A. Product Data: Submit manufacturer's technical data and application instructions. Include the following:
  - 1. Melt Flow Index ASTM D1238
  - 2. Density ASTM D1505
- B. Shop Drawings: The Contractor shall submit complete shop drawings of all materials furnished for this project.

### PART 2 - PRODUCT

#### 2.1 GENERAL

- A. Manufacturer
  - 1. All HDPE pipe and fittings shall be from a single manufacturer, who is fully experienced, reputable and qualified in the manufacture of the HDPE Pipe to be furnished. The pipe shall be designed, constructed and installed in accordance with the best practices and methods and shall comply with these Specifications.
  - 2. Qualified manufacturers shall be: PLEXCO Division of Chevron Chemical Company, DRISCOPIPE as manufactured by Phillips Products Co., Inc. SCLAIRPIPE as manufactured by Dupont of Canada, or equal as approved by the Engineer.
- B. Quality Control
  - 1. Production staff shall check each length of pipe produced for the items listed below. The results of all measurements shall be recorded on production sheets, which become part of the manufacturer's permanent records.
    - a. Pipe in process shall be checked visually, inside and out for cosmetic defects (grooves, pits, hollows, etc.)
    - b. Pipe outside diameter shall be measured using a suitable periphery tape to ensure conformance with ASTM F714 or ASTM D3035, whichever is applicable.
    - c. Pipe wall thickness shall be measured at 12 equally spaced locations around the circumference at both ends of the pipe to ensure conformance with ASTM F714 or ASSTM D3035, whichever is applicable.
    - d. Pipe length shall be measured.
    - e. Pipe marking shall be examined and checked for accuracy.
    - f. Pipe ends shall be checked to ensure they are cut square and clean.
    - g. Subject inside surface to a "reverse bend test" to ensure the pipe is free of oxidation (brittleness).



- C. Testing
  - 1. The polyethylene pipe manufacturer shall provide certification that stress regression testing has been performed on the specific polyethylene resin being utilized in the manufacture of this product. This stress regression testing shall have been done in accordance with ASTM D2837 and the manufacturer shall provide a product supplying a minimum Hydrostatic Design Basis (HDB) of 1,600 psi as determined in accordance with ASTM D2837.
- D. Compatibility
  - 1. Contractor is responsible for compatibility between pipe materials, fittings and appurtenances.

## 2.2 MATERIALS FOR PIPE SIZES 4-INCH DIAMETER AND LARGER

- A. Materials used for the manufacture of polyethylene pipe and fittings shall be made from a PE 3408 high density polyethylene resin compound meeting cell classification 345434C per ASTM D3350; and meeting Type III, Class C, Category 5, Grade P34 per ASTM D1238.
- B. High Density Polyethylene (HDPE) pipe shall comply with AWWA Specifications C906.
- C. If rework compounds are required, only those generated in the Manufacturer's own plant from resin compounds of the same class and type from the same raw material supplier shall be used.
- D. Dimensions and workmanship shall be as specified by ASTM F714. HDPE fittings and transitions shall meet ASTM D3261. HDPE pipe shall have a minimum density of 9.955 grams per cubic centimeter. All HDPE pipe and fittings shall have a Hydrostatic Design Basis (HDB) of 1,600 psi.
- E. HDPE pipe and accessories shall be 200 psi at 73.4°F meeting the requirements of Dimension Ratio (DR) 11 as MINIMUM STRENGTH.
- F. HDPE pipe used for waterlines shall be black with exterior blue striping.
- G. The pipe Manufacturer must certify compliance with the above requirements.

## 2.3 FITTINGS

- A. All molded fittings and fabricated fittings shall be fully pressure rated to match the pipe SDR pressure rating to which they are made. All fittings shall be molded or fabricated by the manufacturer. No Contractor fabricated fittings shall be used unless approved by the Engineer.
- B. The manufacturer of the HDPE pipe shall supply all HDPE fittings and accessories as well as any adapters and/or specials required to perform the work as shown on the Drawings and specified herein.

- C. All fittings shall be installed using butt-fused fittings, thermo-fused fittings/couplings, or flanged adapters and must be approved by the Engineer. No size on size wet taps shall be permitted.
- D. Electrofusion Fittings shall be made of HDPE material with a minimum material designation code of PE 3608 and with a minimum Cell Classification as noted in 3.2.A. Electrofusion Fittings shall comply with ASTM F1055. Fittings shall have a pressure rating equal to the pipe unless otherwise specified on the plans. All electrofusion fittings shall be suitable for use as pressure conduits, and have nominal burst values of four times the Working Pressure Rating (WPR) of the fitting. Markings shall be according to ASTM F 1055.
- E. Service connections shall be electrofusion saddles with a brass or stainless steel threaded outlet. The size of the outlet shall be as shown on the plans.
- F. All transition from HDPE pipe to PVC shall be made per the approval of the Engineer and per the HDPE pipe manufacturer's recommendations and specifications. A molded flange connector adapter within a back-up ring assembly shall be used for pipe type transitions. Back up rings shall be stainless steel.
  - 1. A harness restraint or concrete anchor is required at all mechanical couplings to prevent pullout.
  - 2. No solid sleeves shall be allowed between such material transitions.
  - 3. Fittings and transitions shall be as manufactured by Phillips Driscopipe, Inc., 1000 Series Pressure Pipe, Chevron Chemical Company Plexco/Spiralite pipe, or equal.
  - 4. The pipe supplier must certify compliance with the above requirements.

## 2.4 PIPE IDENTIFICATION

- A. The following shall be continuously indent printed on the pipe or spaced at intervals not exceeding 5 feet:
  - 1. Name and/or trademark of the pipe manufacturer.
  - 2. Nominal pipe size.
  - 3. Dimension ratio.
  - 4. The letters PE followed by the polyethylene grade in accordance with ASTM D1248 followed by the hydrostatic design basis in 160's of psi, e.g., PE 3408.
  - 5. Manufacturing standard reference, e.g., ASTM F714 or D-3035, as required.
  - 6. A production code from which the date and place of manufacture can be determined.
  - 7. Color identification, either stripped by co-extruding longitudinal identifiable color markings or shall be solid in color and as follows:
    - a. BLUE – Potable Water

## PART 3 - EXECUTION

### 3.1 JOINTING METHOD

- A. The pipe shall be joined with butt, heat fusion joints as outlined in ASTM D2657. All joints shall be made in strict compliance with the manufacturer's recommendations. A factory qualified joining technician as designated by pipe manufacturer or experienced, trained technician shall perform all heat fusion joints in the present of the inspector.
- B. Lengths of pipe shall be assembled into suitable installation lengths by the butt-fusion process. All pipe so joined shall be made from the same class and type of raw material made by the same raw material supplier. Pipe shall be furnished in standard laying lengths not to exceed 50 feet and no shorter than 20 feet.
- C. On days butt fusions are to be made, the first fusion shall be a trial fusion in the presence of an inspector. The following shall apply:
  - 1. Heating plates shall be inspected for cuts and scrapes. The plate temperature shall be measured at various locations to ensure proper heating/melting per manufacturer's recommendations and approval by the inspector.
  - 2. The fusion or test section shall be cut out after cooling completely for inspection.
  - 3. The test section shall be 12' or 30 times (minimum) the wall thickness in length and 1" or 1.5 times the wall thickness in width (minimum).
  - 4. The joint shall be visually inspected as to continuity of "beads" from the melted material, and for assurance of "cold joint" prevention (i.e., -joint shall have visible molded material between walls of pipe). Joint spacing between the walls of the two ends shall be a minimum of 1/16" to a maximum of 3/16".
- D. Saddle fusion: Saddle fusion shall be done in accordance with ASTM F 2620 or TR-41 or the fitting manufacturer's recommendations and PPI TR-41. Saddle fusion joints shall be made by qualified fusion technicians. Qualification of the fusion technician shall be demonstrated by evidence of fusion training within the past year on the equipment to be utilized on this project.
- E. The polyethylene flange adapters at pipe material transitions shall be backed up by stainless steel flanges conforming to ANSI B16.1 and shaped as necessary to suit the outside dimensions of the pipe. The flange adapter assemblies shall be connected with corrosion resisting bolts and nuts of Type 316 Stainless Steel as specified in ASTM A726 and ASTM A307. All bolts shall be tightened to the manufacturer's specified torques. Bolts shall be tightened alternatively and evenly. After installation apply a bitumastic coating to bolts and nuts.

### 3.2 INSTALLATION

- A. High Density Polyethylene (HDPE) Pipe shall be installed in accordance with the manufacturer recommendations. A factory qualified joining technician as designated by the pipe manufacturer shall perform all heat fusion joints.
- B. HDPE shall be installed by Directional Bore Method.

- C. Care shall be taken in loading, transporting and unloading to prevent injury to pipe. Pipe or fitting shall not be dropped. All pipe or fitting shall be examined before installation, and no piece shall be installed which is found to be defective. Any damage to the pipe shall be repaired as directed by the Engineer. If any defective pipe is discovered after it has been installed, it shall be removed and replaced with a sound pipe in a satisfactory manner by the contractor, at his own expense.
- D. Under no circumstances shall the pipe or accessories be dropped into the trench or forced through a directional bore upon "pull-back".
- E. Care shall be taken during transportation of the pipe such that it will not be cut, kinked or otherwise damaged.
- F. Ropes, fabric or rubber protected slings and straps shall be used when handling pipes. Chains, cables or hooks inserted into the pipe ends shall not be used. Two slings spread apart shall be used for lifting each length of pipe.
- G. Pipes shall be stored on level ground, preferably turf or sand, free of sharp objects, which could damage the pipe. Stacking of the polyethylene pipe shall be limited to a height that will not cause excessive deformation of the bottom layers of pipes under anticipated temperature conditions. Where necessary due to ground conditions, the pipe shall be stored on wooden sleepers, spaced suitably and of such width as not to allow deformation of the pipe at the point of contact with the sleeper or between supports.
- H. Pipe shall be stored on clean level ground to prevent undue scratching or gouging. The handling of the pipe shall be in such a manner that the pipe is not damaged by dragging it over sharp and cutting objects. The maximum allowable depth of cuts, scratches or gouges on the exterior of the pipe is 5 percent of wall thickness. The interior pipe surface shall be free of cuts, gouges or scratches.
- I. Pipe shall be laid to lines and grade shown on the Drawings with bedding and backfill as shown on the Drawings.
- J. When laying is not in progress, including lunchtime, the open ends of the pipe shall be closed by fabricated plugs, or by other approved means.
- K. Sections of pipe with cuts, scratches or gouges exceeding 5 percent of the pipe wall thickness shall be removed completely and the ends of the pipeline rejoined.
- L. The pipe shall be joined by the method of thermal butt fusion, as outlined in PART 3 – Execution, Section 3.1 Joining Method. All joints shall be made in strict compliance with the manufacturer's recommendations.
- M. Mechanical connections of the polyethylene pipe to auxiliary equipment such as valves, pumps and tanks shall be through flanged connections which shall consist of the following.
  - 1. A polyethylene flange shall be thermally butt-fused to the stub end of the pipe.
  - 2. A 316 stainless steel back-up ring shall mate with a 316 stainless steel flange.
  - 3. 316 stainless steel bolts and nuts shall be used.

- N. Flange connections shall be provided with a full-face neoprene gasket.
- O. All HDPE pipe must be at the temperature of the surrounding soil at the time of backfilling and compactions.
- P. If a defective pipe is discovered after it has been installed, it shall be removed and replaced with a sound pipe in a satisfactory manner at no additional cost to the Owner. All pipe and fittings shall be thoroughly cleaned before installation, shall be kept clean until they are used in the work and when laid, shall conform to the lines and grades required.

### 3.3 RECORD KEEPING AND RECORD DRAWINGS

- A. The Contractor shall maintain a daily record of the drilling operations and a guidance system log with a copy given to Engineer at completion of boring.
- B. The MGS data shall be recorded during the actual crossing operation. The Contractor shall furnish as-built plan and profile drawing based on these recordings showing the actual location horizontally and vertically of the installation, and all utility facilities found during the installation. The MGS data shall be certified accurate by the Contractor to the capability of the MGS System.
- C. Record drawings shall be completed and reviewed by the Engineer and prepared at the Contractor's expense. The as-built drawings shall be certified by the Contractor for accuracy.

### 3.4 CLEANING

- A. At the conclusion of the work, thoroughly clean all of the new pipe lines to remove all dirt, stones, pieces of wood or other material which may have entered during the construction period by forcing a cleaning swab through all mains 6" or greater. Flushing velocities shall be a minimum of 2.5 feet per second. All flushing shall be coordinated with the inspector. Debris cleaned from the lines shall be removed from the job site.

### 3.5 PIPE TESTING

- A. Following the successful pullback of the pipe, the Contractor shall hydro-test pipe from end to end.

END OF SECTION 330533.23

## SECTION 331113.02 – LEAD SERVICE LINE REPLACEMENTS

### PART 1 – GENERAL

#### 1.1 SUMMARY

- A. Furnishing all labor, materials, tools, equipment, and services for all Lead Service Line Replacements as shown on the Drawings or included in the Schedule at the end of this Specification.
- B. Although such is not specifically indicated, furnish and install all supplementary or miscellaneous items, appurtenances and devices incidental to or necessary for a functional and complete installation.

#### 1.2 RELATED DOCUMENTS AND SECTIONS

- A. Drawings and general provisions of the Contract, including General Conditions, Supplementary Conditions (if included), and Division 1 Specifications Sections, apply to this Section.
- B. Section 013543 – Environmental Protection
- C. Section -011319.01 Field Test Reporting – Aggregate, Soils, Concrete and Asphalt
- D. Section 016600 – Product Handling and Protection
- E. Section 310000 – Earthwork
- F. UTILITY Standard details, Follow Section 011100. If the OWNER does not have standard details, use ODOT Detail BP-7.1 for pavement, sidewalk, ramps, curbing and related restoration.

#### 1.3 PRODUCTS INSTALLED BUT NOT FURNISHED UNDER THIS SECTION

- A. Granular pipe bedding and cover material specified in Section 310000 – Earthwork.
- B. Special backfill material specified in Section 310000 – Earthwork.

#### 1.4 DEFINITIONS

- A. Bedding: Material placed under, beside and directly over pipe for the full width of the trench up to a distance of 12 inches over the top of the pipe barrel prior to subsequent backfill operations.

#### 1.5 SUBMITTALS

- A. Manufacturer's Affidavit: The manufacturer shall furnish an affidavit indicating that all pipe, fittings, valves, and appurtenances have been manufactured and tested in

accordance with the requirements of the applicable referenced Standards. A copy of the affidavit indicating the Project on which the material is to be used, shall be forwarded to ENGINEER prior to construction.

- B. Method of construction with detailed drawings and written descriptions of the entire construction procedure to connect new water services and restoration. Drawings shall show, but are not limited to, excavation locations, access pits, dimensions, shoring, method of dewatering, adjacent utilities, and traffic control.

## 1.6 REFERENCES

- A. AWWA C600 - Installation of Ductile-Iron Mains and Their Appurtenances
- B. AWWA C651 - Disinfecting Water Mains
- C. AWWA C800 - Underground Service Line Valves & Fittings
- D. AWWA C810 – Replacement and Flushing of Lead Service Lines
- E. ASTM A36 - Standard Specification for Carbon Structural Steel
- F. ASTM B62 - Standard Specification for Composition Bronze or Ounce Metal Castings
- G. ASTM B88 - Standard Specification for Seamless Copper Water Tube
- H. ASTM B124 - Standard Specification for Copper and Copper Alloy Forging Rod, Bar, and Shapes
- I. ANSI B16.18 - Cast Copper Alloy Solder Joint Pressure Fittings
- J. ASTM D698 - Standard Test Methods for Laboratory Compaction Characteristics of Soil Using Standard Effort (12 400 ft-lbf/ft<sup>3</sup> (600 kN-m/m<sup>3</sup>))

## 1.7 QUALITY ASSURANCE

- A. Comply with all provisions of Section 014323 – Qualifications of Tradesmen.
- B. Comply with all provisions of Section 014126 – General Regulations and Permits.
- C. Field samples shall comply with Section 013319 – Field Test Reporting and Section 013326 – Product Testing and Certifying.
- D. Before and during installation, the Contractor shall comply with provisions under Section 013119 – Project Meetings.
- E. All pipes, fittings, valves and appurtenances shall be appropriately marked for identification purposes. The materials and methods of manufacture, and completed pipes, fittings, valves, and appurtenances shall be subject to inspection and rejection at all times. OWNER and ENGINEER have the right to make inspections.

## 1.8 PROJECT CONDITIONS

### A. Environmental Requirements

1. Comply with all provisions of Section 013543 – Environmental Protection at all times.

### B. Existing Conditions

1. Verify locations of underground utilities. OWNER will share GIS and/or other mapping information with selected Contractor as available.
2. Existing water mains to be connected into are assumed to be cast iron pipe mainly with the possibility of ductile iron pipe in few locations.
3. Protect existing structures and utilities from damage. Repair if damaged by this work.
4. Do not change pipe sizes without securing written approval of Engineer.
5. Pot-hole to determine existing service line materials and diameters for all properties included in this project. This includes verifying diameter and type of water main materials that will be tapped for this work. Since most water services are assumed to be 1-inch diameter, tapping saddles will not be needed for very many services.
6. Where services are larger than 1-inch diameter, assume that the water main is a 12-inch diameter main. Any different size water main determined by pot-holing will be justification for a change order for material cost difference to either decrease saddle size or to increase saddle size, but labor to install shall not be adjusted based on diameter of main.
7. Services to empty lots shall not be replaced on this project.

### C. Field Measurements

1. If it becomes necessary to change location of service lines due to underground utility interference, secure approval of Engineer.
2. If service line replacement inside the structure is five feet or less, use the soft copper as specified below.
3. If service line replacement inside the structure exceeds five feet, use rigid copper with “Pro-Press” fittings or Approved Equal.

## 1.9 DELIVERY STORAGE AND HANDLING

- A. Deliver products to the site, store and protect under provisions of Section 016600 – Product Handling and Protection.
- B. Comply with all provisions of Section 013543 – Environmental Protection

## 1.10 SEQUENCING AND SCHEDULING

- A. Perform no pipe work in fill areas until embankment or fill has been completed to at least two (2) feet above proposed top of pipe and fill has been properly compacted.
- B. Perform pot-holing for existing service line materials and existing water main size and material prior to performing any additional work. Review with OWNER and finalize list of service lines to complete, either public, private, or both, based on materials found.



## PART 2 – PRODUCTS

### 2.1 SERVICE CONNECTION ASSEMBLY PIPE

- A. Soft Copper Pipe and Fittings:
  - 1. Pipe: ASTM B88, Type K, annealed, seamless copper water tube; 1-inch minimum.
  - 2. Copper Pressure Fittings: ASME B16.18 cast-copper-alloy, ASME B16.22 wrought copper, or AWWA C800 service line fittings.
  - 3. Joints: Flared connections.
- B. Rigid Copper Pipe and Fittings:
  - 1. Pipe: ASTM B88, Type L, water tube, drawn temper; 1-inch minimum.
  - 2. Copper Pressure Fittings: ASME B16.18, cast-copper-alloy or ASME B16.22, wrought-copper, solder-joint or crimped fittings, or AWWA C800 service line fittings.
  - 3. Joints: ASME B16.24, Class 150, with Solder-joint, crimped ends, “Pro-Press” connections or Approved Equal.

### 2.2 SERVICE CONNECTION ASSEMBLIES

- A. Assemblies include a service saddle, corporation stop, and curb stop and box. All service connections shall be rated to 150 psi working water pressure.
- B. Service saddle shall be used for all services greater than 1-inch diameter and less than 3-inch diameter; and, shall be brass and designed for type of pipe to be installed on, and to accept the corporation stop; Mueller Co. #BR2B, or an approved equivalent.
- C. Corporation stop shall be in accordance with AWWA C800, complete with required coupling and accessories for connection to service pipe; subject to an air test at the factory; Mueller Co. H-15000N, H-15020 for 90 degree bend, or as approved.
- D. Curb stop shall be in accordance AWWA C800, complete with required fittings for the type of connection to service pipe; Mueller Co. #H-15204, or as approved.
- E. Curb box shall be made of steel and cast iron; shut-off rod matching type in the system; for less than 1.5-inch curb stop use Mueller Co. #H-1033448, #H-10314, or as approved, for 1.5-inch or 2-inch curb stop use Tyler Pipe, 6500 Series, screw type, or as approved. Curb box – concrete lid for placement in concrete or asphalt sidewalks or pavements shall be Mueller Model #89376.
- F. Provide the Valve Curb Box Lock as supplied by the JRC Supplies LLC to support each service curb box instead of the brick support for 1” curb stops or smaller.

### 2.3 HOME OWNER SHUTOFF VALVES

- A. Ball Valve

1. Ball valve shall be constructed of Bronze with Buna-N rubber seats, and O-ring stem seals
2. Ends shall be appropriate for the connections in the home.
3. Valve shall open at 1.0 psi differential and seal at 0.25 psi differential.
4. Operations shall be that valve requires a 90 degree turn.
5. Ball valve shall be manufactured by; Mueller Industries Inc Model B&K, or as approved equivalent.

## PART 3 – EXECUTION

### 3.1 PREPARATION

- A. All public and private side water services included in the schedule shall be pot-holed to determine existing service line and water main materials and sizes. For private service lines that meet the definition of Lead Service Line as include in Paragraph 3.5.A. notify the homeowner and the Water Utility immediately. Provide appropriate materials and equipment to tie-in the existing service with the new service. All pot-holing must be completed prior to any new services being replaced, either on public or on private side. Payment for pot-holing is included in the Bid Schedule and Prices to Include. In addition all pot-holed service connections shall include replacement of the curb box with a new curb box.
- B. Excavate trench for Work of this Section; follow Section 310000 - Earthwork.
- C. Location of service connections as field marked are approximate. Final locations will be determined in the field by the Contractor during pot-holing. All new services shall be offset from existing service such that it will not be damaged or disturbed before it's connection to the new service.
- D. Utilize jumpers or other grounding techniques to mitigate stray currents from shocking workers during installation and connection of new service line to the existing private side plumbing system.

### 3.2 BEDDING

- A. Place bedding material at trench bottom and shape for accurate placement and proper support of pipe.
- B. Place in 6-inch layers, loose measurement, and compact by hand or mechanical tamping to not less than 95 percent of maximum density as determined in accordance with ASTM D698 (Standard Proctor).
- C. Carefully place and tamp so as not to damage or displace joints or pipe. Do not drop material directly on pipe.
- D. Maintain optimum moisture content of bedding material to attain required compaction density.

### 3.3 SERVICE CONNECTION ASSEMBLIES

- A. Install assemblies as shown or noted; comply with component manufacturer's instructions.
- B. Minimal allowable distance between tap and pipe joint shall be 18 inches. Minimum distance between taps shall be 18 inches.
- C. Where possible do not install curb boxes in pavement, sidewalks, driveways or aprons, Only when water main is located under a walk, install curb stop between right-of-way and sidewalk. If curb box is located in the sidewalk or driveway, then a concrete bell sleeve shall be used in conjunction with the curb stop and box.
- D. Set valves plumb and on solid bearing; center and plumb valve box over valve; set box cover flush with finished grade; provide expansion joint material around portion of box in concrete pavement or sidewalks.
- E. For 1-inch or smaller curb stops and curb box installations simply place the Vadle curb box lock on a properly prepared sub base under the curb stop. Follow manufacturer's installation instructions.
- F. Install meter pits, meter settings and castings as needed and as required to renew each service.
- G. For existing service connections to be abandoned on existing water mains to remain in service, dig up (expose) and turn off the existing corporation stop at the connection to the existing main. Verify that the abandoned service is water tight (no leaks).
- H. Immediately after a lead service line replacement, property owners shall be notified to flush the service line by running water from an available outside tap or from the inside cold water tap closest to where the service line enters the home. Flush the line at full flow for 30 minutes. If the cold water tap has an aerator (or screen), then remove it prior to flushing, and rinse it free of debris prior to replacing it.
- I. After flushing, install a new aerator filter or previous aerator with a new screen and have such aerator remain on tap for at least 90 days after lead service replacement.

### 3.4 SERVICE CONNECTION PIPE

- A. Installation of service pipe shall be installed by jacking, boring, or moling service connections across roadway to a location close enough to the existing curb valve to make the connection to the existing water service to minimize ground disturbance and restoration. No joints permitted within these limits.
- B. For existing service connections, intercept or extend as shown or noted to connect to water mains. Attempted reconnection into private services shall include up to 10 LF of new copper material from the location of the curb valve, same as public side, and shall be paid for as noted in the Bid Schedule.

- C. If existing private service line material cannot be tied into due to condition, with attempted connection noted above, then Contractor shall immediately notify Water Utility who will make the decision of how to reconnect, which may include replacement of service line in a similar manner to private side lead service lines. Payment for replacement of these private service laterals will be at the property owners expense, but shall be at the same unit cost for private lead service line replacements included in the Bid Schedule.

### 3.5 PRIVATE SIDE LEAD SERVICE LINE REPLACEMENT AND OTHER WORK

- A. Definition: Private side lead service line will be defined as any of the following:
  - 1. A water service line, or a portion thereof, constructed of lead pipe material anywhere along the private service lateral from the public right-of-way to inside the house and terminating at the water meter, internal shut off valve, or other location as determined by the Water Utility.
  - 2. A water service line, or a portion thereof, constructed of galvanized pipe material once fed by a public side lead service line, within the limits defined above.
  - 3. Definition as modified from time to time by Ohio EPA, local, regional, state or federal ordinances, statutes, codes, or laws.
  
- B. The work, method of construction and materials for lead service replacements as applicable, comply with AWWA Standards C651 and C810. All service connections pipe shall be as noted in paragraph 2.1.
  - 1. Complete all lead service line replacements in accordance with AWWA Standard C810 Replacement and Flushing of Lead Service Lines. Trenchless replacement is encouraged wherever possible to minimize restoration on private property.
  - 2. No lead service line shall be reconnected to the water main without written approval provided by the Water Utility.
  - 3. Replacement service lines shall be installed in a similar manner as the existing service line (i.e. if through a crawl space floor, then expect to install through the floor, if through the basement wall, then expect to install through the wall). Patch holes through wall or floor in the private building for water line connection with non-shrink grout or other approved water proof material designed for such use.
  - 4. Copper service line inside the building shall be replaced as noted in Article 1.8.C above.
  - 5. If the copper service line entering the building is NOT in the close proximity to the existing service line then it is most probable that the water meter will need to be relocated as required by Water Utility.
    - a. If such relocation is for the convenience of the Contractor as determined by the Water Utility, then Contractor shall provide the “additional” interior copper and move the meter and shut-off valve as required to complete the work at his cost.
    - b. If such relocation is required due to obstructions and other considerations as determined by the Water Utility, then Contractor shall provide the “additional” interior copper and move the meter and shut-off valve as required to complete the work.
  
- D. If a private side lead service line is found proceed with the following steps.
  - 1. The Contractor shall leave a customer notification hanger on all points of entry to the home or business and notify the Water Utility.

2. The Contractor shall offer each customer to replace lead service lines from the curb box or meter pit to the inlet stop, meter or water valve inside the customer's home or business. No portion of lead service lines shall remain.
3. Contractor shall assume for sake of Bidding that no carpentry work will be required to replace the service line. If the replacement is not covered under the bid items, the Contractor shall provide the Water Utility with a change order and cost estimate for the private side lead service line replacement. Upon approval from the Water Utility, the Contractor shall perform the replacement of the private side lead service line.
4. In the event that a customer refuses a private side lead service line replacement, the Water Utility shall supply the Contractor with lead filters and pitchers that the Contractor shall distribute to this customer, including to all units of multi-unit housing buildings. The filters shall be pour-through pitcher type lead filters that are NSF/ANSI-53 certified to remove lead. The pitcher, a 3-month supply of filters and Water Utility supplied use instructions and other applicable materials shall be distributed. Records of residents whom refuse the private side lead service line replacement or filters shall be provided by the Contractor to the Water Utility.
5. At the beginning of the day that a customer is scheduled to be connected to the water main, the Contractor shall distribute the appropriate Water Utility provided customer notification hanger and other applicable materials on all accessible points to the home or business and in a prominent location at all multi-unit housing buildings. The appropriate door notification will be determined by (1) whether a private side lead service line remains in the project area and (2) the type of material of the individual private side service line.

#### SCHEDULE 1 - BACKFILLING

- A. Backfilling shall be accomplished in a two-step procedure as follows: 1) partial backfill before leakage tests, and 2) completion of backfill after tests. Departure from this procedure due to traffic or other conditions shall be approved by the Engineer.

#### SCHEDULE 2 - MAINTENANCE OF EXISTING DITCHES

- A. The Contractor shall use the utmost care in maintaining ditches and other waterways, and, if either bottoms or banks of such ditches are disturbed, they shall be promptly restored and maintained for the life of the guaranty period. Similar care shall be used in preventing damage to existing pavement by caving of trench walls and undermining such pavement. If pavement is damaged, the Contractor shall repair same at their own expense.

#### SCHEDULE 3 - CLEARING SITE AND RESTORING DAMAGED SURFACES

- A. Upon completion of the backfill work, the Contractor shall immediately remove and dispose of all surplus materials including dirt and rubbish.
- B. Unless otherwise called for on the plans, the Contractor shall replace all pavement, sidewalks, sod, or other surfaces disturbed to a condition equal to that existing before the work was started, furnishing all materials, labor, equipment, etc., at no additional cost to the Owner.

#### SCHEDULE 4 - SCHEDULE OF WATER SERVICE ADDRESSES

- A. The following addresses shall be provided with new public side water services and private side water services if they meet the definition of Lead Service Line per Paragraph 3.5. This list includes services that are believed to contain lead and are intended to be replaced with this project. However, Water Utility reserves the right to add to or remove from this list as deemed appropriate. List and quantities in the Bid Schedule are only intended to compare bids and secure prices, but are not guaranteed.
- B. See attached address list Schedule – 12 pages.
- C. See attached map for general street locations.

END OF SECTION 331113.02

Property Parcel #	Address #	E/W	Street Name	Ext.	Description	Utility Account #	Meter Size	Public	Private	At meter
<b>WEST RIVER RD N - 7 Addresses</b>										
0624121000002	427		West River Rd N			107507054-003	5/8"		Copper	Copper
0624121000001	433		West River Rd N			107507058-004	5/8"		Copper	Copper
0624123000017	447		West River Rd N			107507074-001	5/8"		Copper	Plastic
0624123000015	449		West River Rd N			107507078-001	5/8"		Copper	Copper
0624123000008	451		West River Rd N			107507082-006	5/8"		Copper	Copper
	455		West River Rd N							
	529		West River Rd N							
<b>2ND ST - 38 Addresses</b>										
0626053000008	100		2ND	St		217110110-001	3/4"		Copper	Copper
0626062000027	103		2ND	St		217110170-001	1"		Copper	Copper
0626053000007	104		2ND	St		217110124-002	5/8"		Copper	Copper
0626053000007	106		2ND	St		217110124-002	5/8"		Copper	Copper
0626053000006	114		2ND	St		217110130-001	1 1/2"		Copper	
0626053000005	120		2ND	St		217110136-001	5/8"		Copper	
0626053000004	126		2ND	St		217110152-001	5/8"		Copper	Copper
0626060000008	230		2ND	St		218111170-004			Unknown	
0626060000005	246		2ND	St		218110744-001	1 1/2"			
0626059000013	330		2ND	St	ESSIONAL CHURCH, UNITED CHUR	216105120-001	3"		Copper	
0626059000003	356		2ND	St		216105150-001	1"		Copper	
0626058000008	414		2ND	St		216103706-002	5/8"	Copper	Copper	
0626058000007	422		2ND	St		216103708-002	5/8"	Copper	Copper	Copper
0626065000022	423		2ND	St						
0626058000006	424		2ND	St						
0626065000019	433		2ND	St		216103768-001	5/8"		Copper	Copper
0626065000008	435		2ND	St						
0626066000034	505		2ND	St		215101906-001	5/8"		Copper	Copper
0626066000035	507		2ND	St		215101908-005	5/8"		Copper	Galvanized
0626057000016	508		2ND	St		215102014-001	5/8"		Copper	Copper
0626057000015	510		2ND	St		215102016-002	5/8"		Copper	Copper
0626066000027	511		2ND	St						
0626057000014	514		2ND	St		215102020-002	5/8"		Copper	Copper
0626066000026	519		2ND	St		215101914-001	5/8"			
0626066000036	521		2ND	St		215101918-003	5/8"		Copper	Copper
0626057000009	522		2ND	St		215102030-001	5/8"		Copper	Copper
0626057000008	524		2ND	St		215102036-001	5/8"		Copper	Copper
0626066000037	525		2ND	St		215101920-002	5/8"		Copper	Copper
0626057000007	528		2ND	St		215102040-005	5/8"	Copper	Copper	Copper
0626066000023	531		2ND	St		215101930-002	5/8"			
0626057000006	534		2ND	St		215102046-001	5/8"		Copper	Plastic
0626066000022	535		2ND	St		215101934-002	5/8"		Copper	Copper
0626057000036	538		2ND	St		215102050-006	5/8"	Lead	Copper	Copper
0626057000038	540		2ND	St		215102053-003	5/8"		Copper	Plastic
0626066000021	541		2ND	St		215101938-001	5/8"	Lead	Copper	Copper
0626057000008	601		2ND	St		215101946-001	5/8"	Lead	Copper	Copper
0624100000006	612		2ND	St		201602520-001	5/8"		Copper	Copper
0624100000005	618		2ND	St		201602530-001				
<b>4TH ST - 49 Addresses</b>										
0625098102015	100		4TH	St		321253904-004	5/8"		Copper	
0625098102015	108		4TH	St		321253904-007	5/8"			
0625099000010	111		4TH	St		321253958-007	5/8"		Copper	
0625098102005	112		4TH	St		321253920-003	5/8"		Copper	Copper
0625099000009	113		4TH	St		321253962-001	5/8"		Copper	Copper
0625099000009	115		4TH	St		321253962-001	5/8"		Copper	Copper
0625098102004	116		4TH	St		321253926-001	5/8"		Plastic	Copper
0625099000008	117		4TH	St		321253968-001	5/8"		Galvanized	Copper
0625098102003	120		4TH	St		321253930-001	5/8"		Copper	
0625099000007	123		4TH	St		321253972-001	5/8"		Copper	Copper
0625098102002	126		4TH	St		321253936-001	5/8"		Copper	
0625099000006	127		4TH	St		321253978-001	5/8"		Copper	
0625098102001	130		4TH	St		321253942-002	5/8"		Copper	Copper
0625099000005	133		4TH	St		321253540-002	5/8"		Copper	Plastic
0625099000004	135		4TH	St		321253544-002	5/8"		Copper	Copper
0625098101003	138		4TH	St		321253514-010	5/8"	Galvanized	Copper	
0625099000003	139		4TH	St		321253550-001	5/8"		Galvanized	
0625098101002	142		4TH	St		321253520-001	5/8"		Copper	
0625098101008	144		4TH	St		321253524-005	5/8"		Copper	
0626048000021	201		4TH	St		218111758-001	5/8"		Copper	Copper
0626048000023	207		4TH	St		218111760-002	5/8"		Copper	Copper
0626047000009	240		4TH	St		218111738-001	1 1/2"		Copper	
0626048000004	241		4TH	ST	ST. MARY'S SCHOOL	218111790-001	3"		Galvanized	
0626047000007	246		4TH	ST		218111744-002	5/8"		Copper	Copper
0626047000028	250		4TH	ST		218111748-003	5/8"	Copper	Galvanized	Copper
0626047000004	252		4TH	ST		218111752-008	5/8"	Copper	Plastic	Copper
0626046000021	300		4TH	ST		219113906-001	5/8"		Copper	
0626046000019	312		4TH	ST		219114306-001	5/8"		Galvanized	Galvanized
0626049000017	315		4TH	ST		219114356-001	5/8"		Copper	Copper
0626046000018	316		4TH	ST		219114312-001	5/8"		Copper	Copper
0626046000029	318		4TH	ST		219114316-001	5/8"		Copper	Copper
0626046000014	324		4TH	ST		219114324-001	1"		Copper	Copper
0626049000014	327		4TH	ST		219114372-001	5/8"		Copper	Copper
0626046000013	328		4TH	ST		219114332-001	3/4"		Copper	Plastic
0626049000013	329		4TH	ST		219114376-009	5/8"		Copper	Copper
0626049000012	331		4TH	ST		219114382-001	5/8"	Galvanized	Copper	Copper

Property Parcel #	Address #	E/W	Street Name	Ext.	Description	Utility Account #	Meter Size	Public	Private	At meter
0626046000024	332		4TH	ST		219114346-002	1 1/2"		Copper	
0626049000011	333		4TH	ST		219114386-001	5/8"		Copper	Galvanized
0626049000010	337		4TH	ST		219114546-001	5/8"	Lead	Galvanized	
0626049000009	339		4TH	ST		219114554-002	5/8"		Copper	Copper
0626046000009	340		4TH	ST		219114506-001	5/8"		Copper	Copper
0626049000008	343		4TH	ST		219114558-010	5/8"		Copper	Copper
0626046000008	344		4TH	ST		219114512-001	5/8"		Copper	Copper
0626049000006	345		4TH	ST		219114564-002	5/8"		Copper	Copper
0626046000007	346		4TH	ST		219114518-004	5/8"			
0626046000006	350		4TH	ST		219114524-003	3/4"		Copper	Copper
0626046000005	352		4TH	ST		219114530-002	5/8"		Copper	Copper
0626049000003	355		4TH	ST		219114578-001	5/8"		Copper	Copper
0626046000004	356		4TH	ST		219114536-001	5/8"		Copper	Copper
<b>9TH ST - 25 Addresses</b>										
0626022102018	207		9TH	ST		224126432-003	5/8"			
0626022102019	209		9TH	ST		224126434-001	5/8"		Copper	Plastic
0626019101016	210		9TH	ST		224126406-001	5/8"		Copper	Copper
0626019101015	212		9TH	ST		224126408-001	5/8"			
0626022102014	213		9TH	ST		224126438-002	5/8"		Copper	Copper
0626019101014	214		9TH	ST		224126410-002	5/8"		Copper	Copper
0626022102013	217		9TH	ST		224126444-006	5/8"		Copper	Copper
0626019101013	218		9TH	ST		224126414-002	5/8"			
0626022102012	221		9TH	ST		224126450-004	5/8"	Lead	Copper	Copper
0626019101012	222		9TH	ST		224126418-007	5/8"			
0626022102011	225		9TH	ST		223126230-002	5/8"		Copper	Copper
0626019101010	226		9TH	ST		224126422-001	5/8"		Copper	Plastic
0626022102011	227		9TH	ST		223126230-002	5/8"		Copper	Copper
0626019101009	228		9TH	ST		223126206-001	5/8"			
0626022102011	229		9TH	ST		223126230-002	5/8"	Lead	Copper	Copper
0626019101008	230		9TH	ST		223126208-003	5/8"	Lead	Copper	
0626022102010	231		9TH	ST		223126232-002	5/8"		Copper	
0626022102010	231		9TH	ST		223126232-002	5/8"		Copper	
0626019101007	236		9TH	ST		223126212-003	5/8"		Copper	Plastic
0626019101007	238		9TH	ST		223126212-003	5/8"		Copper	Plastic
0626022102008	241		9TH	ST		223126238-001	5/8"		Copper	Copper
0626019101043	244		9TH	ST	GOOD SHEPHERD BAPTIST CHURCH	223126214-001	5/8"		Copper	Copper
0626022102006	247		9TH	ST		223126242-001	5/8"	Lead	Copper	Copper
0626022102005	249		9TH	ST		223126244-002	5/8"		Copper	Copper
0626019101005	250		9TH	ST		223126216-002	5/8"		Copper	Copper
<b>13TH ST - 17 Addresses</b>										
0626006102018	218		13TH	ST		225130004-001	5/8"		Copper	Copper
0626006102017	220		13TH	ST		225130003-002	5/8"	Copper	Copper	Copper
0626006102015	228		13TH	ST		225130006-001	5/8"		Copper	
0626006101011	229		13TH	ST		225130034-001	5/8"		Copper	Copper
0626006102014	230		13TH	ST		225130008-011	5/8"		Copper	Copper
0626006101010	231		13TH	ST		225130036-004	5/8"		Copper	Galvanized
0626006102013	234		13TH	ST		225130010-002				
0626006102012	236		13TH	ST		225130012-004	5/8"		Copper	Copper
0626006101009	237		13TH	ST		225130040-005	5/8"		Copper	Copper
0626006102011	240		13TH	ST		225130016-001	5/8"		Copper	Copper
0626006102010	244		13TH	ST		225130018-001	5/8"		Copper	Copper
0626006102009	246		13TH	ST		225130020-005	5/8"		Copper	Copper
0626006101006	247		13TH	ST		225130050-004	5/8"		Copper	
0626006102008	250		13TH	ST		225130022-001	5/8"		Copper	Copper
0626006101005	251		13TH	ST		225130054-001	5/8"		Copper	Copper
0626006102007	252		13TH	ST		225130024-002	5/8"	Lead	Copper	Copper
0626006101004	253		13TH	ST		225130056-004		Lead	Copper	
<b>WEST AVE - 105 Addresses</b>										
0626074000001	30		WEST	AVE		216104304-001	5/8"	Lead	Copper	
0626065000016	111		WEST	AVE		216104366-002	5/8"			
0626056000013	211/215		WEST	AVE		216104142-001	5/8"	Lead	Copper	Copper
0626056000014	219		WEST	AVE		216104148-001	5/8"	Copper	Copper	Copper
0626023101004	812		WEST	AVE		220117808-005	5/8"		Copper	Plastic
0626024102048	817		WEST	AVE		220117824-001	5/8"		Copper	Copper
0626023102002	820		WEST	AVE		220117816-001	5/8"	Copper	Copper	Copper
0626023102003	824		WEST	AVE		220117818-005	5/8"	Lead	Copper	
0626024102050	825		WEST	AVE		220117830-003	5/8"	Copper	Copper	
0626023102004	826		WEST	AVE		220117820-005	5/8"			
0626024102053	833		WEST	AVE		220117834-001	5/8"		Copper	Copper
0626024102054	835		WEST	AVE		220117836-001	5/8"	Lead	Copper	Copper
0626018101001	902		WEST	AVE		220119002-001	5/8"		Copper	Copper
0626017000050	903		WEST	AVE		220119016-001	5/8"		Galvanized	Copper
0626018101003	908		WEST	AVE		220119004-001	5/8"		Copper	Copper
0626018101004	912		WEST	AVE		220119006-003			Copper	Copper
0626017000052	917		WEST	AVE		220119020-004	5/8"	Lead	Copper	Copper
0626018102001	918		WEST	AVE		220119008-003	5/8"	Lead	Copper	Copper
0626018102002	922		WEST	AVE		220119010-004	5/8"		Copper	Copper
0626017000053	925		WEST	AVE		220119023-001	5/8"		Copper	Copper
0626018102003	926		WEST	AVE		220119012-003	5/8"		Copper	Copper
0626017000054	929		WEST	AVE		220119024-001	5/8"		Copper	Copper
0626018102004	930		WEST	AVE		220119014-002	5/8"	Lead	Copper	Copper
0626017000055	931		WEST	AVE		220119026-001	5/8"		Copper	Copper
0626016101049	1001		WEST	AVE		220118802-002	5/8"	Lead	Copper	
0626015101001	1004		WEST	AVE		222123319-003	5/8"		Copper	Copper
0626016101050	1005		WEST	AVE		221119202-002	5/8"	Lead	Copper	Copper



Property Parcel #	Address #	E/W	Street Name	Ext.	Description	Utility Account #	Meter Size	Public	Private	At meter
0626016101051	1007		WEST	AVE		221119204-001	5/8"		Copper	Copper
0626015101002	1008		WEST	AVE		222123006-005	5/8"		Copper	Copper
0626016101053	1011		WEST	AVE		221119206-002	5/8"		Copper	Copper
0626016101054	1013		WEST	AVE		221119208-001	5/8"		Copper	Copper
0626015101004	1014		WEST	AVE		222123010-005	5/8"		Unknown	Plastic
0626015102001	1018		WEST	AVE		222123014-001	5/8"		Copper	Copper
0626015102001	1018		WEST	AVE		222123014-001	5/8"		Copper	Copper
0626015102002	1020		WEST	AVE		222123016-006	5/8"		Copper	Copper
0626015102003	1024		WEST	AVE		222123018-001	5/8"	Lead	Galvanized	
0626015102004	1028		WEST	AVE		222123020-001	5/8"		Copper	Copper
0626016102044	1101		WEST	AVE		221119212-006	5/8"	Lead	Copper	Copper
0626015103001	1102		WEST	AVE		222122402-001	5/8"		Copper	Copper
0626015103002	1106		WEST	AVE		222122403-001	3/4"	Lead	Copper	Copper
0626015103003	1108		WEST	AVE		222122404-001	5/8"		Copper	Copper
0626016102046	1109		WEST	AVE		221119210-005	5/8"	Lead	Copper	
0626015103004	1112		WEST	AVE		222122406-001	5/8"		Copper	Copper
0626016102047	1113		WEST	AVE		221119218-006	5/8"	Lead	Copper	Copper
0626016102048	1117		WEST	AVE		221119220-001	5/8"	Lead	Copper	Copper
0626010101001	1118		WEST	AVE		222122408-001	5/8"	Lead	Plastic	Plastic
0626016102049	1121		WEST	AVE		221119224-003	5/8"		Copper	Plastic
0626010101002	1122		WEST	AVE		222122410-002	5/8"			
0626010101003	1126		WEST	AVE		222122412-004	5/8"		Copper	Copper
0626010101004	1130		WEST	AVE		222122414-007	5/8"		Copper	Copper
0626009000034	1133		WEST	AVE		221119228-001	5/8"		Copper	
0626009000035	1135		WEST	AVE		221119230-006	5/8"		Copper	Copper
0626009000036	1137		WEST	AVE		221119232-004	5/8"			
0626009000043	1141		WEST	AVE		221119234-002	5/8"	Lead	Plastic	Galvanized
0626009000039	1149		WEST	AVE		221119238-004	5/8"	Galvanized	Copper	Copper
0626009000040	1151		WEST	AVE		221119240-015	5/8"			
0626010102001	1202		WEST	AVE		222121902-003	5/8"			
0626010102002	1206		WEST	AVE		222121903-003	5/8"		Copper	Plastic
0626010102003	1208		WEST	AVE		222121904-012	5/8"		Copper	Copper
0626010102004	1212		WEST	AVE		222121906-014				
0626008102017	1213		WEST	AVE		221120704-004				
0626007102001	1304		WEST	AVE		222121604-001	5/8"		Copper	Copper
0626007102002	1306		WEST	AVE		222121606-004	5/8"	Lead	Copper	Copper
0626008103017	1307		WEST	AVE		221120718-001	5/8"		Copper	Copper
0626007102003	1312		WEST	AVE		222121608-002	5/8"			
0626008103019	1315		WEST	AVE		221120722-004	5/8"		Galvanized	Copper
0626002101001	1320		WEST	AVE		222121612-002				
0626002101003	1412		WEST	AVE		221121338-003		Lead	Copper	
0626002102001	1504		WEST	AVE		221120904-004	5/8"		Copper	
0626001102030	1509		WEST	AVE		221120732-001	5/8"		Copper	Copper
0626001102031	1513		WEST	AVE		221120734-001	5/8"			
0626001102032	1517		WEST	AVE		221120736-004	5/8"	Lead	Copper	Copper
0626001102033	1519		WEST	AVE		226132438-001	5/8"	Lead	Copper	Copper
1000003116001	1600		WEST	AVE						
1000003116002	1602		WEST	AVE						
1000003114004	1605		WEST	AVE		226132826-002	5/8"		Copper	Copper
1000003116003	1606		WEST	AVE		226132810-001	5/8"		Copper	Copper
1000003116004	1610		WEST	AVE		226132812-003	5/8"	Copper	Copper	Plastic
1000003114006	1611		WEST	AVE						
1000003116005	1612		WEST	AVE		226132814-002	5/8"		Copper	Copper
1000003114007	1617		WEST	AVE		226132830-002	5/8"			
1000003114008	1621		WEST	AVE		226132836-001	5/8"		Copper	Copper
1000003117001	1700		WEST	AVE		226134004-002	5/8"	Lead	Copper	Plastic
1000003115001	1703		WEST	AVE		226134030-004	5/8"		Copper	Copper
1000003117002	1704		WEST	AVE		226134008-008	5/8"		Copper	Copper
1000003115002	1705		WEST	AVE		226134031-001	5/8"		Copper	Copper
1000003117003	1706		WEST	AVE		226134006-001	5/8"		Copper	Copper
1000003115003	1707		WEST	AVE		226134032-006	5/8"		Copper	Copper
1000003115004	1711		WEST	AVE		226134034-002	5/8"		Copper	Copper
1000003117005	1712		WEST	AVE		226134014-004	5/8"		Plastic	Plastic
1000003117037	1716		WEST	AVE		226134016-001	5/8"		Copper	Copper
1000003115007	1721		WEST	AVE		226134038-003	5/8"		Copper	Copper
1000003115008	1777		WEST	AVE		226134050-002	5/8"	Copper	Copper	Copper
1000003118038	1800		WEST	AVE		226134604-002	5/8"		Copper	Copper
1000003115010	1809		WEST	AVE		226134632-001	5/8"		Copper	Copper
1000003118004	1810		WEST	AVE		226134608-003	5/8"		Copper	Copper
1000003118005	1816		WEST	AVE		226134612-001	5/8"		Copper	Copper
1000003118007	1826		WEST	AVE		226134618-002	5/8"	Copper	Copper	Copper
1000003115011	1827		WEST	AVE		226134638-001	5/8"		Copper	Copper
1000003115012	1831		WEST	AVE		226134640-004	5/8"		Galvanized	Plastic
1000003115013	1835		WEST	AVE		226134642-001	5/8"		Galvanized	Galvanized
1000003115014	1839		WEST	AVE		226134644-006	5/8"		Copper	Copper
1000003115016	1847		WEST	AVE		226134648-001	5/8"		Copper	Copper
1000003115053	1853		WEST	AVE		226134650-002	5/8"		Copper	Copper
1000003120047	1906		WEST	AVE		226135010-001	5/8"		Copper	Copper
<b>BATH ST - 59 Addresses</b>										
0624056000016	118		BATH	ST		110528304-004	5/8"		Copper	Copper
0624056000015	122		BATH	ST		110528308-011	5/8"		Copper	Copper
0624056000014	128		BATH	ST		110528312-002	5/8"		Copper	Copper
0624056000010	150		BATH	ST		110528326-001	5/8"		Copper	Copper
0624056000009	154		BATH	ST		110528330-004	5/8"	Lead	Copper	Copper
0624056000007	162		BATH	ST		110528338-004	5/8"		Copper	Copper
0624056000006	164		BATH	ST		110528342-002	5/8"		Copper	Copper

Property Parcel #	Address #	E/W	Street Name	Ext.	Description	Utility Account #	Meter Size	Public	Private	At meter
0624056000005	172		BATH	ST		111528504-001	5/8"		Copper	Copper
0624056000001	176		BATH	ST		111528512-002	5/8"		Copper	Copper
0624056000001	184		BATH	ST		111528520-005	5/8"		Copper	Copper
0624063102003	188		BATH	ST		111528524-001	5/8"		Copper	Galvanized
0624063102002	192		BATH	ST		111528528-006	5/8"		Copper	Copper
0624063102001	196		BATH	ST		111528532-003	5/8"		Copper	Copper
0624056000002	182		BATH	ST		111528516-002	5/8"		Copper	Copper
0624055103035	107		BATH	ST		110528352-004				
0624055103034	111		BATH	ST		110528354-001	5/8"		Copper	Copper
0624055103033	115		BATH	ST		110528356-007	5/8"	Lead	Copper	Copper
0624055103032	119		BATH	ST		110528360-001	5/8"		Copper	Copper
0624055103031	121		BATH	ST		110528364-001	5/8"		Copper	Copper
0624055103042	137		BATH	ST		110528372-001	5/8"		Copper	Copper
0624055103024	139		BATH	ST		110528376-003	5/8"	Lead	Copper	Plastic
0624055103023	141		BATH	ST		110528380-002	5/8"			
0624055103022	143		BATH	ST		110528384-001	5/8"		Copper	Galvanized
0624055103021	149		BATH	ST		110528388-002	5/8"	Lead	Copper	Galvanized
0624055102006	167		BATH	ST		111528538-002	5/8"		Copper	Copper
0624055102007	165		BATH	ST		110528392-001	5/8"		Copper	Copper
0624055102004	171		BATH	ST		111528546-001	5/8"		Galvanized	Galvanized
0624055102008	161		BATH	ST		110528390-001	5/8"		Copper	Copper
0624055101004	179		BATH	ST		111528550-001	5/8"		Copper	Copper
0624055101003	181		BATH	ST		111528554-002	5/8"		Copper	Copper
0624055101002	183		BATH	ST		111528558-001	5/8"		Copper	Copper
0624064103001	193		BATH	ST		111528570-005	5/8"		Galvanized	Plastic
0624063101004	244		BATH	ST		109525218-003	5/8"		Copper	Copper
0624063101013	206		BATH	ST		109525308-003	5/8"		Copper	Copper
0624063101012	208		BATH	ST		109525312-001	5/8"		Copper	Copper
0624063101011	210		BATH	ST		109525316-001	5/8"		Galvanized	Galvanized
0624063101010	214		BATH	ST		109525320-002	5/8"		Copper	Copper
0624063101009	218		BATH	ST		109525324-005	5/8"	Lead	Copper	Plastic
0624063101008	222		BATH	ST		109525328-001	5/8"	Lead	Galvanized	
0624063101007	224		BATH	ST		109525332-005	5/8"			
0624063101006	230		BATH	ST		109525204-001	5/8"		Copper	
0624063101005	232		BATH	ST		109525210-002	5/8"		Copper	Plastic
0624063101003	246		BATH	ST		109525224-001	5/8"		Copper	Copper
0624064101022	203		BATH	ST		109525340-005	5/8"		Copper	Copper
0624064101009	245		BATH	ST	ST. AGNES CATHOLIC CHURCH	109525244-001	5/8"		Copper	Copper
0624064101012	237		BATH	ST		109525236-001	5/8"		Copper	Copper
0624064101013	235		BATH	ST				Copper	Copper	
0624064101014	233		BATH	ST		109525228-002	5/8"			
0624064101015	229		BATH	ST		109525226-001	5/8"	Lead	Copper	Copper
0624064101016	225		BATH	ST		109525364-003	5/8"		Copper	Copper
0624064101017	223		BATH	ST		109525360-002	5/8"		Copper	Copper
0624064101018	219		BATH	ST		109525356-001	5/8"		Copper	Copper
0624064101019	213		BATH	ST		109525352-002	5/8"		Copper	Copper
0624064101020	211		BATH	ST		109525348-003	5/8"		Copper	Copper
0624064101021	207		BATH	ST		109525344-002	5/8"			
0624064101011	243		BATH	ST		109525240-001	5/8"		Copper	Copper
0624063101014			BATH	ST				Copper	Galvanized	
0624056000012	136		BATH	ST		110528320-002	5/8"	Lead	Copper	Copper
0624056000011	142		BATH	ST		110528324-002	5/8"		Copper	
<b>BLAKE ST - 16 Addresses</b>										
0624009105003	109		BLAKE	ST		202607034-006	5/8"		Copper	Copper
0624009105002	111		BLAKE	ST		202607038-005	5/8"			
0624009107009	112		BLAKE	ST		202607004-002	5/8"	Lead	Galvanized	
0624009105001	113		BLAKE	ST						
0624009107008	114		BLAKE	ST		202607008-001	5/8"	Copper	Copper	Copper
0624009107007	118		BLAKE	ST		202607012-004	5/8"	Copper	Copper	Copper
0624009104006	121		BLAKE	ST		202607048-003	5/8"		Copper	Copper
0624009107005	124		BLAKE	ST		202607016-001	5/8"		Copper	Galvanized
0624009104005	125		BLAKE	ST		202607050-001	5/8"		Copper	Copper
0624009104004	127		BLAKE	ST		202607054-001	5/8"	Copper	Copper	Copper
0624009107004	128		BLAKE	ST						
0624009107003	130		BLAKE	ST		202607024-002	5/8"		Copper	Copper
0624009104003	131		BLAKE	ST		202607058-002	5/8"		Copper	Copper
0624009104002	135		BLAKE	ST		202607062-001	5/8"	Copper	Copper	Galvanized
0624009107002	136		BLAKE	ST		202607028-001	5/8"		Copper	Copper
0624009104008	139		BLAKE	ST		202607066-001	5/8"		Copper	Copper
<b>MADISON ST - 10 Addresses</b>										
0624067105001	111		MADISON	ST		113536020-001	5/8"	Lead	Plastic	Galvanized
0624068105006	115		MADISON	ST		113536024-001	5/8"		Copper	Plastic
0624068105005	117		MADISON	ST		113536028-001	5/8"		Galvanized	Galvanized
0624068105001	131		MADISON	ST		113536040-001	5/8"		Copper	Copper
0624069105010	135		MADISON	ST		113536044-001	5/8"		Copper	Copper
0624069105009	137		MADISON	ST		113536046-001	5/8"		Copper	
0624069105008	141		MADISON	ST		113536048-002	5/8"		Copper	Copper
0624068105014	127		MADISON	ST		113536036-005	5/8"		Copper	Copper
0624068105004	121		MADISON	ST		113536032-001	5/8"		Copper	Copper
0624069105019	143		MADISON	ST		113536052-002	5/8"		Copper	Copper
<b>LOUISIANA AVE - 80 Addresses</b>										
0624028118012	106		LOUISIANA	AVE		112531604-001	5/8"		Copper	Copper
0624028114018	109		LOUISIANA	AVE		112531630-001	5/8"		Copper	Copper
0624028118006	116		LOUISIANA	AVE		112531608-001	5/8"		Copper	Copper
0624028114016	117		LOUISIANA	AVE		112531634-001	5/8"		Copper	Copper

Property Parcel #	Address #	E/W	Street Name	Ext.	Description	Utility Account #	Meter Size	Public	Private	At meter
0624028118005	120		LOUISIANA	AVE		112531612-004	5/8"		Copper	Copper
0624028114015	121		LOUISIANA	AVE		112531638-001	5/8"		Copper	Copper
0624028118008	124		LOUISIANA	AVE		112531614-003	5/8"		Copper	Copper
0624028114014	125		LOUISIANA	AVE		112531642-013	5/8"		Copper	Copper
0624028118010	128		LOUISIANA	AVE		112531616-006	5/8"		Copper	Copper
0624028114013	129		LOUISIANA	AVE		112531646-001	5/8"		Copper	Copper
0624028118002	134		LOUISIANA	AVE		112531620-001	5/8"		Copper	Galvanized
0624028114012	135		LOUISIANA	AVE		112531650-005	5/8"		Copper	
0624028118001	138		LOUISIANA	AVE		112531624-001	5/8"		Copper	Copper
0624028114011	143		LOUISIANA	AVE		112531654-001	5/8"		Copper	Copper
0624028117012	202		LOUISIANA	AVE		112531804-004	5/8"	Copper	Copper	Copper
0624028113022	203		LOUISIANA	AVE		112531844-004	5/8"		Copper	Galvanized
0624028117011	206		LOUISIANA	AVE						
0624028113021	207		LOUISIANA	AVE		112531848-004	5/8"		Copper	Copper
0624028117010	210		LOUISIANA	AVE		112531810-006	5/8"	Copper	Copper	Copper
0624028113020	211		LOUISIANA	AVE		112531852-001	5/8"		Copper	Copper
0624028117009	214		LOUISIANA	AVE		112531812-001	5/8"		Copper	Copper
0624028113019	215		LOUISIANA	AVE		112531858-001	5/8"		Copper	Copper
0624028117008	220		LOUISIANA	AVE		112531816-001	5/8"		Copper	Copper
0624028113018	221		LOUISIANA	AVE		112531862-001	5/8"		Copper	Copper
0624028117013	224		LOUISIANA	AVE		112531820-002	5/8"		Copper	Copper
0624028113017	225		LOUISIANA	AVE		112531866-004	5/8"	Copper	Copper	Galvanized
0624028113016	229		LOUISIANA	AVE		112531870-002	5/8"		Copper	Copper
0624028117005	232		LOUISIANA	AVE		112531824-001	5/8"		Copper	Copper
0624028113015	235		LOUISIANA	AVE		112531874-001	5/8"	Copper	Copper	Copper
0624028117004	236		LOUISIANA	AVE		112531828-001	5/8"		Copper	Copper
0624028113014	239		LOUISIANA	AVE		112531878-001	5/8"		Copper	Copper
0624028117003	242		LOUISIANA	AVE		112531832-003	5/8"		Copper	Copper
0624028113013	245		LOUISIANA	AVE		112531882-001	5/8"		Copper	Copper
0624028117002	246		LOUISIANA	AVE		112531836-002	5/8"		Copper	Copper
0624028113012	251		LOUISIANA	AVE		112531886-008	5/8"		Copper	Copper
0624028117001	252		LOUISIANA	AVE		112531840-001	5/8"		Copper	Copper
0624028112026	301		LOUISIANA	AVE		112532034-002	5/8"		Copper	Copper
0624028112025	305		LOUISIANA	AVE		112532036-001	5/8"		Plastic	Copper
0624028116013	306		LOUISIANA	AVE		112532004-003	5/8"	Copper	Copper	Copper
0624028116012	308		LOUISIANA	AVE		112532008-001	5/8"		Copper	Copper
0624028116011	310		LOUISIANA	AVE		112532012-001	5/8"		Copper	Copper
0624028112024	311		LOUISIANA	AVE		112532040-001	5/8"	Lead	Galvanized	Galvanized
0624028116010	314		LOUISIANA	AVE		112532016-001	5/8"		Copper	Copper
0624028112023	315		LOUISIANA	AVE		112532044-004	5/8"		Copper	Copper
0624028112022	319		LOUISIANA	AVE		112532048-001	5/8"	Lead	Copper	Copper
0624028116009	320		LOUISIANA	AVE		112532020-001	5/8"		Copper	Copper
0624028112021	323		LOUISIANA	AVE		112532052-001	5/8"			
0624028116008	324		LOUISIANA	AVE		112532024-001	5/8"			
0624028116007	328		LOUISIANA	AVE		112532028-001	5/8"		Copper	
0624028112020	329		LOUISIANA	AVE		112532056-004	5/8"	Lead	Copper	Plastic
0624028116006	332		LOUISIANA	AVE		112532204-001	5/8"		Copper	Copper
0624028112019	333		LOUISIANA	AVE		112532228-001	5/8"		Copper	Copper
0624028116005	336		LOUISIANA	AVE		112532208-003	5/8"		Copper	Copper
0624028112018	339		LOUISIANA	AVE		112532232-001	5/8"	Copper	Copper	Copper
0624028116004	342		LOUISIANA	AVE		112532212-002	5/8"		Copper	Copper
0624028112017	343		LOUISIANA	AVE		112532236-001	5/8"		Copper	Copper
0624028116003	346		LOUISIANA	AVE		112532216-002	5/8"			
0624028112016	347		LOUISIANA	AVE		112532240-002	5/8"		Copper	Copper
0624028116002	350		LOUISIANA	AVE		112532220-001	5/8"		Copper	Copper
0624028112015	351		LOUISIANA	AVE		112532244-001	5/8"			
0624028112014	355		LOUISIANA	AVE		112532248-004	5/8"		Copper	Copper
0624028116001	356		LOUISIANA	AVE		112532224-002	5/8"		Copper	Copper
0624028111034	401		LOUISIANA	AVE		112532448-001	5/8"		Copper	Copper
0624028115010	404		LOUISIANA	AVE		112532408-001	5/8"		Copper	Copper
0624028111033	405		LOUISIANA	AVE		112532452-001	5/8"		Copper	Copper
0624028115009	410		LOUISIANA	AVE		112532412-001	5/8"		Copper	Copper
0624028111032	411		LOUISIANA	AVE		112532456-001	5/8"		Copper	Copper
0624028111031	417		LOUISIANA	AVE		112532460-001	5/8"		Copper	Copper
0624028115007	418		LOUISIANA	AVE		112532416-001	5/8"			
0624028111030	419		LOUISIANA	AVE		112532464-001	5/8"		Copper	Galvanized
0624028115006	420		LOUISIANA	AVE		112532420-001	5/8"		Copper	Copper
0624028111029	423		LOUISIANA	AVE		112532468-001	5/8"		Copper	Copper
0624028111028	427		LOUISIANA	AVE		112532470-002	5/8"		Copper	Copper
0624028115005	428		LOUISIANA	AVE		112532426-003	5/8"	Copper	Copper	Copper
0624028115004	432		LOUISIANA	AVE		112532430-001	5/8"		Galvanized	
0624028111027	433		LOUISIANA	AVE		112532472-001	5/8"		Copper	Galvanized
0624028111026	437		LOUISIANA	AVE		112532476-002	5/8"		Copper	Galvanized
0624028115003	438		LOUISIANA	AVE		112532434-001	5/8"		Copper	Copper
0624028111025	443		LOUISIANA	AVE		112532480-001	5/8"		Copper	Copper
0624070106001	446		LOUISIANA	AVE		112532442-003	5/8"	Copper	Copper	Copper
<b>LINCOLN CT - 14 Addresses</b>										
0625104000012	108		LINCOLN	CT		321252710-006	5/8"		Copper	
0625105000010	109		LINCOLN	CT		321252810-001	5/8"		Galvanized	Copper
0625105000009	113		LINCOLN	CT		321252816-001	5/8"		Copper	
0625104000011	114		LINCOLN	CT		321252716-010	5/8"	Lead	Copper	Copper
0625104000010	116		LINCOLN	CT		321252720-001	5/8"		Copper	
0625104000009	118		LINCOLN	CT		321252726-003	5/8"	Copper	Copper	
0625105000008	121		LINCOLN	CT		321252820-001	5/8"		Copper	Copper
0625104000008	124		LINCOLN	CT		321252730-002	5/8"	Lead	Copper	Copper
0625105000007	125		LINCOLN	CT		321252826-001	5/8"	Copper	Copper	Copper

Property Parcel #	Address #	E/W	Street Name	Ext.	Description	Utility Account #	Meter Size	Public	Private	At meter
0625104000007	126		LINCOLN	CT		321252736-004	5/8"	Lead	Copper	Copper
0625105000006	129		LINCOLN	CT		321252830-001	5/8"		Copper	
0625104000006	130		LINCOLN	CT		321252740-001	5/8"		Copper	
0625105000005	133		LINCOLN	CT		321252834-004	5/8"		Copper	Copper
0625105000004	137		LINCOLN	CT		321252840-005	5/8"		Copper	Copper
<b>EUCLID ST - 11 Addresses</b>										
0624049105038	100		EUCLID	ST		112531204-005	5/8"		Copper	Copper
0624049105037	102		EUCLID	ST		112531206-003	5/8"		Copper	Copper
0624049105036	106		EUCLID	ST		112531208-005	5/8"		Copper	Copper
0624049105035	110		EUCLID	ST		112531212-008	5/8"		Copper	Plastic
0624049105034	114		EUCLID	ST		112531216-001	5/8"		Copper	Copper
0624049105033	116		EUCLID	ST		112531218-004	5/8"		Copper	Copper
0624049105032	118		EUCLID	ST		112531220-005			Copper	
0624049106002	121		EUCLID	ST		112531124-002	3/4"	Copper	Copper	Copper
0624049105031	122		EUCLID	ST		112531224-002	5/8"		Copper	Copper
0624049106001	125		EUCLID	ST		112531128-001	3/4"	Copper	Copper	Copper
0624049105030	126		EUCLID	ST		112531228-003	5/8"	Copper	Copper	
<b>WINCKLES - 64 Addresses</b>										
0625016103019	128		WINCKLES	ST		405310616-003	5/8"		Copper	
0625016103006	130		WINCKLES	ST		405310620-003	5/8"		Copper	
0625016102018	133		WINCKLES	ST						
0625016103007	134		WINCKLES	ST		405310624-002	5/8"		Copper	
0625016103008	136		WINCKLES	ST		405310628-002	5/8"			
0625016102019	137		WINCKLES	ST		405310654-002	5/8"		Copper	
0625016102021	147		WINCKLES	ST		405310664-001	5/8"			
0625016103017	148		WINCKLES	ST		405310634-001	3/4"		Copper	
0625016106001	200		WINCKLES	ST		303210404-001	5/8"		Copper	Copper
0625016106005	214		WINCKLES	ST		303210414-003	5/8"		Copper	
0625016105027	215		WINCKLES	ST		303210020-001	5/8"		Copper	
0625016105028	217		WINCKLES	ST						
0625016106006	218		WINCKLES	ST		303210418-001	5/8"	Copper	Copper	Copper
0625016106007	220		WINCKLES	ST		303210422-002	5/8"		Copper	
0625016106008	224		WINCKLES	ST		303210426-001	5/8"		Copper	Copper
0625016106009	226		WINCKLES	ST		303210430-005	5/8"	Lead	Copper	
0625016106010	230		WINCKLES	ST		303210434-001	5/8"		Copper	
0625016105034	235		WINCKLES	ST		303210044-002	5/8"		Copper	
0625016106012	236		WINCKLES	ST		303210440-003	5/8"	Copper	Copper	
0625016105035	237		WINCKLES	ST		303210048-007	5/8"		Galvanized	
0625016106014	240		WINCKLES	ST		303210444-001	5/8"		Copper	Copper
0625016106015	242		WINCKLES	ST		303210450-003	5/8"		Copper	Plastic
0625016106016	248		WINCKLES	ST		303210454-002	5/8"		Copper	
0625016106017	250		WINCKLES	ST		303210458-001	1"			
0625016106019	254		WINCKLES	ST		303210464-010	5/8"	Lead	Copper	Copper
0625016106021	264		WINCKLES	ST		303210474-002	5/8"		Galvanized	Copper
0625016106022	268		WINCKLES	ST		303210478-001	5/8"		Copper	
0625016106023	270		WINCKLES	ST		303210484-001	5/8"	Lead	Copper	Copper
0625016106024	274		WINCKLES	ST		303210490-002	5/8"	Copper	Copper	Copper
0625016106025	280		WINCKLES	ST		303210492-002	1"			
0625016109019	300		WINCKLES	ST		303209604-001	5/8"		Copper	
0625016109003	308		WINCKLES	ST		303209610-003	5/8"		Copper	Copper
0625016108021	311		WINCKLES	ST		303209650-001	5/8"		Copper	Copper
0625016109004	312		WINCKLES	ST		303209614-002	5/8"			
0625016108022	315		WINCKLES	ST		303209654-004	5/8"		Copper	Copper
0625016109005	316		WINCKLES	ST		303209618-002	5/8"		Copper	
0625016109006	318		WINCKLES	ST		303209620-005	5/8"	Lead	Galvanized	Copper
0625016108023	319		WINCKLES	ST		303209660-002	5/8"		Copper	
0625016109007	320		WINCKLES	ST		303209624-001	5/8"	Lead	Copper	Copper
0625016108024	321		WINCKLES	ST		303209664-001	5/8"		Copper	
0625016109008	324		WINCKLES	ST		303209628-004	5/8"		Copper	Copper
0625016108025	325		WINCKLES	ST		303209670-005				
0625016108026	327		WINCKLES	ST		303209676-008	5/8"	Lead	Copper	
0625016109009	328		WINCKLES	ST		303209204-005	5/8"			
0625016109010	330		WINCKLES	ST		303209208-001	5/8"		Copper	Copper
0625016108028	331		WINCKLES	ST		303209250-001	5/8"	Copper	Copper	Copper
0625016109011	334		WINCKLES	ST		303209212-002	5/8"		Galvanized	
0625016108029	335		WINCKLES	ST		303209254-001	5/8"		Copper	Copper
0625016109012	336		WINCKLES	ST		303209216-001	5/8"		Copper	Copper
0625016108030	337		WINCKLES	ST		303209258-008	5/8"	Lead	Copper	
0625016108031	339		WINCKLES	ST		303209262-001	5/8"		Copper	
0625016109013	340		WINCKLES	ST		303209220-001	5/8"		Copper	
0625016109014	342		WINCKLES	ST		303209224-005	5/8"		Copper	Copper
0625016108032	343		WINCKLES	ST		303209266-001	5/8"		Copper	
0625016109015	344		WINCKLES	ST		303209228-001	5/8"	Copper	Copper	
0625016109016	346		WINCKLES	ST		303209232-001	5/8"		Copper	Copper
0625016114004	416		WINCKLES	ST		311241420-003	5/8"		Copper	
0625016113012	417		WINCKLES	ST		311241470-001	5/8"		Copper	
0625016114005	418		WINCKLES	ST		311241424-003	5/8"		Copper	Copper
0625016114006	422		WINCKLES	ST		311241430-001	5/8"		Copper	Copper
0625016113013	423		WINCKLES	ST		311241474-002	5/8"		Galvanized	
0625016114007	426		WINCKLES	ST		311241434-003	5/8"		Copper	
0625006101004	429		WINCKLES	ST		311241480-004	5/8"		Copper	Copper
0625006102001	430		WINCKLES	ST		311241440-001	5/8"		Copper	
<b>EADY - 23 Addresses</b>										
0625012102009	112		EADY	CT		405311804-001	5/8"		Copper	
0625012102010	114		EADY	CT		405311806-001	5/8"		Copper	Copper

Property Parcel #	Address #	E/W	Street Name	Ext.	Description	Utility Account #	Meter Size	Public	Private	At meter
0625012102052	116		EADY	CT						
	120		EADY	CT		405311814-001	5/8"		Copper	
	121		EADY	CT						
	124		EADY	CT						
	126		EADY	CT						
0625012101008	129		EADY	CT		405311866-001	5/8"		Copper	
	132		EADY	CT						
0625012101009	133		EADY	CT		405311868-005	5/8"		Copper	
	134		EADY	CT						
0625012101010	137		EADY	CT		405311872-002	5/8"		Copper	
0625012101011	141		EADY	CT		405311874-001	5/8"		Copper	
0625012102019	144		EADY	CT		405311834-001	5/8"	Copper	Copper	
0625012101012	145		EADY	CT		405311876-001	5/8"		Copper	
	146		EADY	CT						
0625012101013	147		EADY	CT		405311878-001	5/8"	Copper	Copper	
0625012102022	154		EADY	CT		405311844-003	5/8"		Copper	
0625012102024	158		EADY	CT		405311849-002	5/8"	Copper	Copper	
0625012102025	160		EADY	CT		405311850-002	5/8"	Copper	Copper	
	169		EADY	CT						
0625012102054	170		EADY	CT		405311854-001	5/8"	Copper	Copper	
0625012101021	175		EADY	CT		405311889-001	5/8"		Copper	
<b>3RD ST - 11 Addresses</b>										
0626051000019	230		3RD	ST		995800547-001	1"	Copper	Copper	Copper
0626051000007	244		3RD	ST	ST. MARY'S SCHOOL	218111360-001	2"		Copper	
0626050000012	312		3RD	ST	IRST METHODIST CHURCH OF ELYRI	216105508-001	2"		Iron	
0626050000007	340		3RD	ST		216105532-001	2"		Galvanized	
0626050000005	354		3RD	ST		216105559-002	5/8"		Copper	
0626050000005	354		3RD	ST		216105559-002	5/8"		Copper	
0626050000001	356		3RD	ST		219114706-001	5/8"		Copper	Copper
0626050000001	363		3RD	ST		216105590-002	3"		Copper	
0626041000005	416		3RD	ST		216103908-001	3/4"		Copper	Copper
0626056000010	419		3RD	ST		216103950-003	5/8"		Copper	Copper
0626041000028	420		3RD	ST		216103912-001	5/8"		Copper	Copper
<b>RIVERSIDE CT - 9 Addresses</b>										
0625106000004	108		RIVERSIDE	CT		321252910-001	5/8"		Copper	Copper
0625106000001	112		RIVERSIDE	CT		321252914-001	5/8"	Copper	Copper	
0625107000006	118		RIVERSIDE	CT		321252920-003	1 1/2"		Copper	
0625107000006	120		RIVERSIDE	CT		321252920-003	1 1/2"		Copper	
0625108000004	123		RIVERSIDE	CT						
0625108000002	124		RIVERSIDE	CT		321252922-003	5/8"	Lead	Copper	Copper
0625108000001	126		RIVERSIDE	CT		321252926-006	5/8"	Lead	Copper	
0625109000004	130		RIVERSIDE	CT		321252930-009	5/8"		Copper	Copper
0625109000008	131		RIVERSIDE	CT		321252974-008	5/8"	Lead	Copper	Copper
<b>RIVERSIDE DR - 21 Addresses</b>										
0626024102003	810		RIVERSIDE	DR		220118402-001	5/8"		Copper	Copper
0626024102006	820		RIVERSIDE	DR		220118404-002	5/8"	Copper	Copper	Copper
0626017000001	902		RIVERSIDE	DR		220118406-002	5/8"		Galvanized	Copper
0626017000002	906		RIVERSIDE	DR		220118408-001	5/8"		Copper	Copper
0626017000003	910		RIVERSIDE	DR		220118410-001	5/8"		Copper	Copper
0626017000004	914		RIVERSIDE	DR						
0626017000005	918		RIVERSIDE	DR		220118414-001	5/8"		Copper	Copper
0626016101001	1002		RIVERSIDE	DR		221119802-001	5/8"		Copper	Copper
0626016101002	1006		RIVERSIDE	DR		221119804-001	5/8"		Copper	Copper
0626016101003	1010		RIVERSIDE	DR		221119806-005	5/8"		Copper	Copper
0626016101004	1014		RIVERSIDE	DR		221119808-001	5/8"		Copper	Copper
0626016101005	1018		RIVERSIDE	DR		221119810-001	5/8"		Copper	Copper
0626016102001	1102		RIVERSIDE	DR		221119814-001	5/8"		Copper	Copper
0626016102002	1106		RIVERSIDE	DR		221119816-001	5/8"		Copper	Copper
0626016102003	1110		RIVERSIDE	DR		221119818-001	5/8"		Copper	Copper
0626016102004	1116		RIVERSIDE	DR		221119820-002	5/8"		Copper	Copper
0626016102005	1120		RIVERSIDE	DR		221119822-001	5/8"		Copper	Copper
0626009000001	1132		RIVERSIDE	DR		221119828-001	5/8"		Copper	Copper
0626009000018	1140		RIVERSIDE	DR						
0626009000019	1146		RIVERSIDE	DR		221119834-001	5/8"		Copper	Copper
0626009000020	1152		RIVERSIDE	DR		221119836-002	5/8"		Copper	Copper
<b>8TH ST - 33 Addresses</b>										
0626022101013	208		8TH	ST		223124806-006	5/8"		Copper	Copper
0626027000035	209		8TH	ST		223124840-001	5/8"		Copper	Copper
0626027000030	211		8TH	ST		223124844-002	5/8"		Copper	Copper
0626022101012	214		8TH	ST		223124810-001	5/8"		Copper	Galvanized
0626026000034	309		8TH	ST		223124306-005	5/8"	Lead	Copper	
0626023102016	314		8TH	PL		223124140-001	5/8"		Galvanized	Copper
0626026000033	315		8TH	ST		223124312-004	5/8"	Lead	Galvanized	Galvanized
0626023102015	316		8TH	PL		223124142-003	5/8"	Copper	Copper	Copper
0626023101017	318		8TH	ST		223124216-003	5/8"	Lead	Copper	
0626026000031	319		8TH	ST		223124314-005	5/8"		Copper	Copper
0626023101016	320		8TH	ST		223124218-001	5/8"		Copper	Copper
0626026000030	321		8TH	ST				Lead		
0626023101015	322		8TH	ST		223124220-002	5/8"			
0626023101014	324		8TH	ST		223124222-009	5/8"		Copper	Copper
0626026000029	325		8TH	ST		223124320-007	5/8"	Lead	Copper	Copper
0626026000028	327		8TH	ST		223124322-004	5/8"		Copper	Plastic
0626023102026	329		8TH	ST						
0626023102026	329		8TH	ST						
0626026000026	331		8TH	ST		223124324-004	5/8"		Copper	Copper

Property Parcel #	Address #	E/W	Street Name	Ext.	Description	Utility Account #	Meter Size	Public	Private	At meter
0626023101013	332		8TH	ST		223124224-002	5/8"	Lead	Copper	Copper
0626026000025	333		8TH	ST		223124326-001	5/8"		Galvanized	
0626026000024	335		8TH	ST		223124328-001	5/8"	Lead	Copper	Copper
0626026000023	337		8TH	ST		223124330-002	5/8"		Copper	Copper
0626023101011	340		8TH	ST		223124230-001	5/8"		Copper	Copper
0626023101010	342		8TH	ST		223124232-004	5/8"	Lead	Copper	Copper
0626026000022	343		8TH	ST		223124334-014	5/8"	Lead	Copper	Copper
0626026000021	345		8TH	ST						
0626023101009	346		8TH	ST		223124234-001	5/8"		Copper	Copper
0626026000020	349		8TH	ST		223124338-001	5/8"	Copper	Copper	Copper
0626023101008	352		8TH	ST		223124236-004	5/8"	Copper	Copper	Copper
0626026000019	353		8TH	ST		223124340-003	5/8"		Copper	Copper
0626023101007	355		8TH	ST		220117810-011			Unknown	
0626026000018	357		8TH	ST		223124342-002	5/8"			
<b>15TH ST - 24 Addresses</b>										
0626003102032	200		15TH	ST		225131004-001	5/8"		Copper	Copper
0626003101016	201		15TH	ST		225131036-007	5/8"		Copper	Copper
0626003101015	203		15TH	ST		225131038-001	5/8"		Copper	Copper
0626003102016	204		15TH	ST		225131006-001	5/8"		Copper	Copper
0626003101014	205		15TH	ST		225131040-001	5/8"	Copper	Copper	Copper
0626003102015	206		15TH	ST		225131008-011	5/8"		Copper	Copper
0626003101013	207		15TH	ST		225131042-001	5/8"		Copper	Copper
0626003102014	208		15TH	ST		225131010-004	5/8"		Copper	Plastic
0626003101012	209		15TH	ST		225131044-002	5/8"		Copper	Copper
0626003102013	210		15TH	ST		225131012-001	5/8"		Copper	Copper
0626003101011	211		15TH	ST		225131046-001	5/8"		Copper	Galvanized
0626003101010	213		15TH	ST		225131048-001	5/8"		Copper	Copper
0626003102011	214		15TH	ST		225131016-001	5/8"		Copper	Copper
0626003101009	215		15TH	ST		225131050-002	5/8"		Copper	Copper
0626003102010	216		15TH	ST		225131018-003	5/8"	Lead	Copper	Copper
0626003101008	217		15TH	ST		225131052-005	5/8"			
0626003102009	218		15TH	ST		225131020-003	5/8"		Copper	Copper
0626003101007	219		15TH	ST		225131054-001	5/8"		Copper	Copper
0626003102008	220		15TH	ST		225131022-001	5/8"		Copper	Copper
0626003101006	221		15TH	ST		225131056-003	5/8"		Copper	Copper
0626003101005	223		15TH	ST		225131058-002	5/8"		Copper	Copper
0626003102006	224		15TH	ST		225131024-001	5/8"		Copper	Copper
0626003101004	225		15TH	ST		225131060-005	5/8"	Copper	Copper	Copper
0626003102005	226		15TH	ST		225131026-002	5/8"		Copper	Copper
<b>16TH ST - 14 Addresses</b>										
0626003102026	267		16TH	ST		225131660-008	5/8"	Copper	Copper	Copper
0626003102024	269		16TH	ST		225131664-001	5/8"		Copper	Copper
1000004101060	270		16TH	ST		225131620-001	5/8"		Copper	Copper
0626003102023	271		16TH	ST		225131670-001	5/8"		Copper	Copper
0626003102022	273		16TH	ST		225131674-002	5/8"	Copper	Copper	Copper
0626003102020	277		16TH	ST		225131677-002	5/8"		Copper	Copper
0626003102018	279		16TH	ST				Copper	Copper	
1000004101006	290		16TH	ST		225131630-001	5/8"		Copper	Copper
1000004101004	292		16TH	ST		225131634-001	5/8"	Lead	Copper	Copper
1000004101002	294		16TH	ST		225131636-001	5/8"		Copper	Copper
062600102035	427		16TH	ST	SECOND BAPTIST CHURCH	226132460-001	5/8"		Copper	Copper
1000003107025	510		16TH	ST		203617010-001	5/8"			
1000003107023	514		16TH	ST						
1000003107001	524		16TH	ST		203617050-009	5/8"	Copper	Copper	
<b>FRANKLIN - 45 Addresses</b>										
0624055101001	110		FRANKLIN	AVE		111528706-002	5/8"		Copper	Copper
0624055102001	113		FRANKLIN	AVE		111528740-001	5/8"		Copper	Copper
0624054102005	115		FRANKLIN	AVE		111528744-001	5/8"		Copper	Galvanized
0624054102004	117		FRANKLIN	AVE		111528748-002	5/8"		Copper	Copper
0624054101003	118		FRANKLIN	AVE		111528712-004	5/8"			
0624054101002	120		FRANKLIN	AVE		111528716-005	5/8"	Copper	Copper	Copper
0624054102003	121		FRANKLIN	AVE		111528752-002	5/8"		Copper	Copper
0624054102002	123		FRANKLIN	AVE		111528756-006	5/8"		Copper	Copper
0624054101001	126		FRANKLIN	AVE		111528720-002	5/8"		Copper	Copper
0624054102001	127		FRANKLIN	AVE		111528760-002	5/8"	Copper	Copper	Copper
0624053101004	128		FRANKLIN	AVE		111528724-002	5/8"		Copper	Copper
0624053102006	129		FRANKLIN	AVE		111528764-003	5/8"		Copper	Copper
0624053101002	134		FRANKLIN	AVE		111528730-001	5/8"		Copper	Copper
0624052101002	209		FRANKLIN	AVE		113535448-001	5/8"		Copper	Copper
0624067106007	210		FRANKLIN	AVE		113535404-003	5/8"	Copper	Copper	Plastic
0624052101001	213		FRANKLIN	AVE		113535450-001	5/8"		Copper	Copper
0624068106010	214		FRANKLIN	AVE		113535408-001	5/8"	Copper	Copper	Copper
0624051101006	217		FRANKLIN	AVE		113535454-002	5/8"	Copper	Copper	Copper
0624068106009	218		FRANKLIN	AVE						
0624051101005	221		FRANKLIN	AVE		113535458-003	5/8"		Copper	Copper
0624051101004	223		FRANKLIN	AVE		113535460-003	5/8"		Copper	Copper
0624068106011	224		FRANKLIN	AVE		113535418-001	5/8"		Copper	Copper
0624051101003	225		FRANKLIN	AVE		113535462-001	5/8"		Copper	Copper
0624068106006	228		FRANKLIN	AVE		113535422-001	5/8"		Copper	Copper
0624051101002	229		FRANKLIN	AVE		113535466-001	5/8"	Copper	Copper	Galvanized
0624068106005	230		FRANKLIN	AVE		113535424-006	5/8"		Copper	Copper
0624051101001	231		FRANKLIN	AVE		113535468-001	5/8"	Copper	Copper	Copper
0624069106008	234		FRANKLIN	AVE		113535428-002	5/8"		Copper	Copper
0624050101009	235		FRANKLIN	AVE		113535472-006	5/8"		Copper	Copper
0624050101008	237		FRANKLIN	AVE		113535474-003	5/8"		Copper	Copper

Property Parcel #	Address #	E/W	Street Name	Ext.	Description	Utility Account #	Meter Size	Public	Private	At meter
0624069106007	238		FRANKLIN	AVE		113535432-001	5/8"		Copper	Copper
0624069106006	240		FRANKLIN	AVE		113535434-001	5/8"		Copper	Copper
0624050101007	241		FRANKLIN	AVE		113535478-009	5/8"		Copper	Copper
0624050101006	243		FRANKLIN	AVE		113535480-001	5/8"		Copper	Copper
0624069106004	246		FRANKLIN	AVE		113535440-001	5/8"		Copper	Copper
0624069106003	250		FRANKLIN	AVE		113535442-001	5/8"		Copper	Copper
0624069106002	252		FRANKLIN	AVE		113535444-001	5/8"		Copper	Copper
0624070106009	308		FRANKLIN	AVE		112533804-002	5/8"		Copper	Copper
0624049101006	309		FRANKLIN	AVE		112533840-001	5/8"	Copper	Copper	Copper
0624070106008	310		FRANKLIN	AVE		112533808-001	5/8"			
0624049101005	311		FRANKLIN	AVE		112533810-001	5/8"		Copper	Plastic
0624049101003	317		FRANKLIN	AVE		112533842-002	5/8"		Copper	
0624049101002	319		FRANKLIN	AVE		112533844-002	5/8"		Copper	Copper
0624070106004	320		FRANKLIN	AVE		112533826-001	5/8"		Copper	Copper
0624049101001	327		FRANKLIN	AVE		112533850-001	5/8"		Copper	Copper
<b>HAYES AVE - 36 Addresses</b>										
0624055102002	110		HAYES	AVE		111528910-002	5/8"		Copper	
0624054102009	116		HAYES	AVE		111528914-001	5/8"		Copper	Copper
0624054102008	120		HAYES	AVE		111528918-005	5/8"		Copper	Copper
0624054102007	122		HAYES	AVE		111528922-008	5/8"	Copper	Copper	Copper
0624054102006	126		HAYES	AVE		111528924-004	5/8"		Copper	Copper
0624052101004	208		HAYES	AVE		113535004-001	5/8"		Copper	Copper
0624052101003	212		HAYES	AVE		113535008-003	5/8"		Copper	Copper
0624052102001	213		HAYES	AVE		113535046-001	5/8"		Copper	Copper
0624051102006	215		HAYES	AVE		113535050-001	5/8"		Copper	Copper
0624051101012	216		HAYES	AVE		113535012-001	5/8"		Copper	Copper
0624051101011	218		HAYES	AVE		113535016-007	5/8"	Copper	Copper	Copper
0624051102005	219		HAYES	AVE		113535054-002	5/8"	Copper	Copper	Copper
0624051102004	221		HAYES	AVE		113535058-003	5/8"	Copper	Copper	Copper
0624051101010	222		HAYES	AVE		113535020-008	5/8"		Copper	Copper
0624051101009	224		HAYES	AVE		113535024-003	5/8"		Copper	Copper
0624051102003	225		HAYES	AVE						
0624051102002	227		HAYES	AVE		113535066-001	5/8"	Lead	Copper	Copper
0624051101008	228		HAYES	AVE		113535028-013	5/8"		Plastic	Plastic
0624051101007	230		HAYES	AVE		113535032-004	5/8"		Copper	Copper
0624051102001	231		HAYES	AVE		113535070-003	5/8"		Copper	
0624050101013	234		HAYES	AVE		113535036-001	5/8"		Copper	Copper
0624050102010	235		HAYES	AVE		113535074-001	5/8"		Copper	Copper
0624050102009	237		HAYES	AVE		113535078-003	5/8"		Copper	Copper
0624050101012	238		HAYES	AVE		113535040-002	5/8"			
0624050101014	240		HAYES	AVE		113535042-005	5/8"		Copper	Copper
0624050102008	241		HAYES	AVE		113535082-001	5/8"		Copper	Copper
0624050102007	243		HAYES	AVE		113535086-006	5/8"			
0624050101015	244		HAYES	AVE		113535044-001	5/8"		Copper	Copper
0624049102006	311		HAYES	AVE		112533624-002	5/8"		Copper	Copper
0624049101011	314		HAYES	AVE		112533604-002	5/8"		Copper	Copper
0624049101010	318		HAYES	AVE		112533608-003	5/8"		Copper	Copper
0624049102004	319		HAYES	AVE		112533630-010	5/8"	Copper	Copper	Plastic
0624049101009	320		HAYES	AVE		112533610-001	5/8"		Copper	Copper
0624049101008	324		HAYES	AVE		112533612-001	5/8"		Copper	Copper
0624049102002	325		HAYES	AVE		112533636-002	5/8"		Copper	Copper
0624049102001	327		HAYES	AVE		112533640-001	5/8"		Copper	Copper
<b>WARREN AVE - 68 Addresses</b>										
0625015106030	113		WARREN	AVE		303212220-001	5/8"		Galvanized	
0625015107005	114		WARREN	AVE		303212420-002	5/8"		Copper	Plastic
0625015106031	115		WARREN	AVE		303212222-001	5/8"		Copper	
0625015107006	116		WARREN	AVE		303212423-001	5/8"		Copper	
0625015107007	120		WARREN	AVE		303212426-009	5/8"		Copper	Copper
0625015106032	121		WARREN	AVE		303212228-007	5/8"		Copper	
0625015106033	123		WARREN	AVE		303212230-001	5/8"		Plastic	Copper
0625015107008	124		WARREN	AVE		303212430-001	5/8"	Copper	Copper	
0625015106034	127		WARREN	AVE		303212232-004	5/8"		Copper	Copper
0625015107009	128		WARREN	AVE		303212434-001	5/8"		Copper	Copper
0625015107011	134		WARREN	AVE		303212440-001	5/8"		Galvanized	
0625015106035	135		WARREN	AVE		303212238-001	5/8"	Copper	Copper	
0625015107012	138		WARREN	AVE		303212444-004	5/8"		Galvanized	Copper
0625015106037	141		WARREN	AVE		303212244-003	5/8"		Copper	Copper
0625015107014	142		WARREN	AVE		303212448-004	5/8"		Copper	
0625015107015	146		WARREN	AVE		303212452-001	5/8"		Copper	
0625015106038	147		WARREN	AVE		303212248-001	5/8"		Copper	
0625015107016	148		WARREN	AVE		303212454-001	5/8"		Copper	
0625015106039	149		WARREN	AVE		303212250-002	5/8"		Copper	
0625015107017	152		WARREN	AVE		303212456-008	5/8"		Copper	
0625015106040	153		WARREN	AVE		303212254-001	5/8"		Copper	
0625015106041	155		WARREN	AVE		303212256-001	5/8"		Copper	
0625015107018	156		WARREN	AVE		303212460-001	5/8"		Copper	
0625015106042	157		WARREN	AVE		303212260-001	5/8"	Copper	Copper	
0625015106043	161		WARREN	AVE		303212264-002	5/8"		Copper	
0625015107020	162		WARREN	AVE		303212466-001	5/8"		Copper	Galvanized
0625015106044	165		WARREN	AVE		303212268-005	5/8"		Copper	Copper
0625015107022	166		WARREN	AVE		303212470-001	5/8"		Copper	
0625015107024	168		WARREN	AVE		303212474-001	5/8"		Copper	
0625015106045	169		WARREN	AVE		303212272-003	5/8"	Copper	Copper	Copper
0625015106046	173		WARREN	AVE		303212274-001	5/8"		Copper	
0625015106047	175		WARREN	AVE		303212276-003	5/8"	Lead	Copper	Plastic
0625015107025	176		WARREN	AVE		303212480-003	5/8"	Lead	Copper	Copper

Property Parcel #	Address #	E/W	Street Name	Ext.	Description	Utility Account #	Meter Size	Public	Private	At meter
0625015106048	177		WARREN	AVE		303212280-001	5/8"		Copper	
0625015106049	179		WARREN	AVE		303212286-001	5/8"		Copper	
0625015107026	180		WARREN	AVE		303212483-001	5/8"		Copper	
0625015107027	182		WARREN	AVE		303212486-004	5/8"		Copper	Copper
0625015110001	200		WARREN	AVE		303212003-002	5/8"		Copper	Copper
0625015109026	201		WARREN	AVE		303211808-001	5/8"		Copper	
0625015109027	203		WARREN	AVE		303211812-001	5/8"		Copper	
0625015110002	204		WARREN	AVE		303212006-001	5/8"		Copper	Copper
0625015109028	207		WARREN	AVE						
0625015110004	210		WARREN	AVE		303212010-001	5/8"		Copper	Copper
0625015109029	211		WARREN	AVE		303211824-002	5/8"		Copper	Copper
0625015110005	214		WARREN	AVE		303212014-001	5/8"		Copper	
0625015109030	215		WARREN	AVE		303211830-003	5/8"		Copper	Copper
0625015109031	217		WARREN	AVE		303211832-007	5/8"			
0625015110022	218		WARREN	AVE		303212018-001	5/8"		Copper	
0625015109032	221		WARREN	AVE		303211836-001	5/8"		Copper	
0625015109033	223		WARREN	AVE		303211840-001	5/8"		Copper	
0625015110009	224		WARREN	AVE		303212024-001	5/8"		Copper	Copper
0625015109034	227		WARREN	AVE		303211844-001	5/8"		Copper	
0625015110010	228		WARREN	AVE		303212028-001	5/8"			
0625015109035	231		WARREN	AVE		303211850-001	5/8"		Copper	
0625015110011	232		WARREN	AVE		303212032-001	5/8"		Copper	
0625015109036	233		WARREN	AVE		303211854-001	5/8"		Copper	Copper
0625015110012	234		WARREN	AVE		303212036-003	5/8"		Copper	Copper
0625015109037	237		WARREN	AVE		303211860-007	5/8"		Copper	
0625015110013	238		WARREN	AVE		303212042-001	5/8"	Copper	Copper	Copper
0625015109038	239		WARREN	AVE		303211862-001	5/8"	Copper	Copper	
0625015110014	242		WARREN	AVE		303212046-011	5/8"		Copper	Copper
0625015109039	243		WARREN	AVE		303211866-001	5/8"		Copper	
0625015110015	246		WARREN	AVE						
0625015109041	247		WARREN	AVE		303211870-001	5/8"		Galvanized	
0625015110016	250		WARREN	AVE		303212056-001	5/8"		Copper	Copper
0625015110017	254		WARREN	AVE		303212062-009	5/8"	Copper	Copper	Copper
0625015109043	255		WARREN	AVE		303211878-005	5/8"	Lead	Copper	
0625015110018	258		WARREN	AVE		303212066-001	5/8"		Copper	
<b>EAST RIVER ST - 29 Addresses</b>										
0625116000004	407		EAST RIVER	ST		301200456-003	5/8"		Copper	Plastic
0625081000001	412		EAST RIVER	ST	MEDICLINIC PHYSICIANS & URGEN	301200806-001	1"		Copper	
0625116000019	417		EAST RIVER	ST		301200464-001	5/8"		Copper	Copper
0625080000018	424		EAST RIVER	ST		301200425-001	1"		Copper	
0625079000001	436		EAST RIVER	ST		301200440-001	3/4"		Copper	
0625115000004	507		EAST RIVER	ST		301201260-001	5/8"		Copper	Copper
0625114000001	521		EAST RIVER	ST	IORIAL HOSPITAL REGIONAL MEDI	301201286-001	5/8"	Copper	Copper	Copper
0625110000006	635		EAST RIVER	ST	IORIAL HOSPITAL REGIONAL MEDI	320252644-001	2"		Copper	
0625108000010	661		EAST RIVER	ST		320252672-001	5/8"		Copper	Copper
0625107000004	673		EAST RIVER	ST		995803563-001			Unknown	
0625106000005	677		EAST RIVER	ST		320252680-001	5/8"		Copper	
0625105000011	685		EAST RIVER	ST		320252684-002	5/8"		Copper	Copper
0625074101002	700		EAST RIVER	ST		320252410-001	5/8"		Copper	
0625104000013	701		EAST RIVER	ST		320254006-001	5/8"		Copper	
0625074101003	702		EAST RIVER	ST		320252416-001	5/8"		Copper	
0625104000014	703		EAST RIVER	ST		320254010-007	5/8"		Copper	Copper
0625104000015	705		EAST RIVER	RD		320254014-004	5/8"		Copper	
0625074101004	706		EAST RIVER	ST		320252420-001	5/8"		Copper	
0625103000013	709		EAST RIVER	ST		320254020-008	5/8"		Copper	Copper
0625103000014	711		EAST RIVER	ST		320254024-001	5/8"	Lead	Copper	Copper
0625102000016	715		EAST RIVER	ST		320254030-001	5/8"		Copper	
0625102000023	717		EAST RIVER	ST		320254036-005	5/8"		Copper	Plastic
0625101000013	719		EAST RIVER	ST		320254040-001	5/8"		Plastic	Copper
0625073103001	720		EAST RIVER	ST	EW LIFE BAPTIST CHURCH OF ELYRIA					
0625101000014	725		EAST RIVER	ST		320254046-001	5/8"		Copper	Galvanized
0625100000014	801		EAST RIVER	ST		320254250-001	5/8"	Copper	Copper	
0625100000015	809		EAST RIVER	ST				Lead	Galvanized	
0625099000011	813		EAST RIVER	ST		320254260-006	5/8"	Lead	Copper	
0625099000012	821		EAST RIVER	ST		320254270-001	5/8"	Copper	Copper	Copper
<b>WATER ST - 15 Addresses</b>										
0626069000013	5		WATER	ST		215101436-001	5/8"		Copper	Copper
0626069000014	7		WATER	ST		215101440-009	5/8"		Galvanized	Copper
0626069000015	9		WATER	ST		215101442-001	5/8"		Copper	Copper
0626066000001	102		WATER	ST		215101412-003	5/8"		Copper	Copper
0626067000001	103		WATER	ST		215101450-002	5/8"		Copper	Copper
0626066000002	106		WATER	ST		215101416-002	5/8"		Plastic	Copper
0626067000003	109		WATER	ST		215101456-001	5/8"		Copper	Copper
0626066000003	110		WATER	ST		215101418-001	5/8"		Copper	Copper
0626066000004	112		WATER	ST		215101420-001	5/8"		Copper	Copper
0626067000004	113		WATER	ST		215101460-004	5/8"	Lead	Galvanized	Plastic
0626067000005	115		WATER	ST						
0626066000017	116		WATER	ST		215101424-002	5/8"	Lead	Galvanized	Galvanized
0626066000017	118		WATER	ST		215101424-002	5/8"		Galvanized	Galvanized
0626066000020	120		WATER	ST		215101429-003	5/8"		Copper	Copper
0626067000007	121		WATER	ST		215101470-001	5/8"		Copper	Galvanized
<b>TAFT AVE - 29 Addresses</b>										
0624054103017	111		TAFT	AVE		111529236-010	5/8"		Copper	Galvanized
0624055103018	116		TAFT	AVE		111529210-007	5/8"		Galvanized	Galvanized
0624055103016	118		TAFT	AVE						



Property Parcel #	Address #	E/W	Street Name	Ext.	Description	Utility Account #	Meter Size	Public	Private	At meter
0624054103015	119		TAFT	AVE		111529242-005	5/8"	Copper	Copper	Copper
0624055103015	120		TAFT	AVE		111529218-001	5/8"		Copper	Copper
0624054103014	121		TAFT	AVE		111529246-005	5/8"		Copper	Copper
0624055103014	122		TAFT	AVE		111529222-001	5/8"		Copper	Galvanized
0624054103013	123		TAFT	AVE		111529250-006	5/8"		Copper	Copper
0624055103013	126		TAFT	AVE		111529226-005	5/8"		Copper	Copper
0624054103012	127		TAFT	AVE		111529254-002	5/8"	Copper	Copper	Copper
0624055103012	130		TAFT	AVE		111529230-006	5/8"	Copper	Copper	
0624054103011	131		TAFT	AVE		111529258-003	5/8"			
0624055103011	134		TAFT	AVE		111529264-001	3/4"	Copper	Copper	
0624055103009	140		TAFT	AVE		111529104-002	5/8"	Copper	Copper	Copper
0624054103008	141		TAFT	AVE		111529134-001	5/8"		Copper	Copper
0624054103007	143		TAFT	AVE		111529138-002	5/8"		Copper	Copper
0624055103041	144		TAFT	AVE		111529108-001	5/8"		Copper	
0624054103006	147		TAFT	AVE		111529142-001	5/8"		Copper	Copper
0624055103006	148		TAFT	AVE		111529113-002	5/8"		Copper	Copper
0624055103005	150		TAFT	AVE						
0624054103005	151		TAFT	AVE		111529146-001	5/8"		Copper	Copper
0624055103004	152		TAFT	AVE	LORAIN METROPOLITAN HOUSING	111529118-001	5/8"		Copper	Copper
0624054103004	153		TAFT	AVE		111529150-001	5/8"			
0624055103003	156		TAFT	AVE	LORAIN METROPOLITAN HOUSING	111529120-001	5/8"		Copper	Copper
0624054103003	157		TAFT	AVE		111529154-006	5/8"		Copper	
0624054103002	159		TAFT	AVE		111529158-001	5/8"		Copper	Copper
0624055103002	160		TAFT	AVE						
0624054103001	163		TAFT	AVE		111529162-002	5/8"		Copper	Copper
0624055103001	164		TAFT	AVE		111529124-007	5/8"	Copper	Copper	Plastic

**FURNACE ST - 65 Addresses**

0624054103018	404		FURNACE	ST		111529404-008	5/8"	Lead	Galvanized	Copper
0624053103018	406		FURNACE	ST		111529408-009	5/8"		Copper	Plastic
0624053103016	414		FURNACE	ST		111529416-001	5/8"		Copper	Copper
0624053103015	418		FURNACE	ST		111529420-004	5/8"	Copper	Copper	Copper
0624052104011	500		FURNACE	ST				Lead	Galvanized	
0624052105005	501		FURNACE	ST		111529842-002	5/8"		Copper	Copper
0624052104010	504		FURNACE	ST		111529808-001	5/8"		Copper	Copper
0624052104009	508		FURNACE	ST		111529812-001	5/8"		Copper	Galvanized
0624052105003	509		FURNACE	ST		111529848-001	5/8"		Copper	Copper
0624052104008	510		FURNACE	ST		111529816-001	5/8"		Copper	Copper
0624052105002	513		FURNACE	ST		111529852-001	5/8"		Copper	Copper
0624052104007	514		FURNACE	ST		111529820-003	5/8"		Copper	Copper
0624051104012	516		FURNACE	ST		111529824-002	5/8"		Copper	Copper
0624051105006	519		FURNACE	ST		111529856-004	5/8"		Copper	Copper
0624051104011	520		FURNACE	ST		111529828-001	5/8"		Copper	Copper
0624051104010	522		FURNACE	ST		111529832-001	5/8"		Galvanized	Galvanized
0624051105005	523		FURNACE	ST		111529860-001	5/8"		Galvanized	Galvanized
0624051105004	525		FURNACE	ST		111529862-001	5/8"		Copper	Copper
0624051104009	526		FURNACE	ST						
0624051105003	527		FURNACE	ST		111529864-001	5/8"		Copper	Copper
0624051104008	528		FURNACE	ST						
0624051105002	531		FURNACE	ST						
0624051104007	532		FURNACE	ST		111530008-001	5/8"		Lead	Galvanized
0624051105001	533		FURNACE	ST		111530038-003	5/8"		Copper	Galvanized
0624050104011	536		FURNACE	ST		111530012-001	5/8"	Copper	Copper	Galvanized
0624050105005	539		FURNACE	ST		111530044-001	5/8"		Copper	Copper
0624050104010	540		FURNACE	ST						
0624050104009	544		FURNACE	ST		111530020-001	5/8"		Copper	Copper
0624050105004	545		FURNACE	ST		111530048-001	5/8"		Copper	Copper
0624050104008	546		FURNACE	ST				Lead	Galvanized	
0624050105002	549		FURNACE	ST		111530052-003	5/8"		Copper	Copper
0624050104006	552		FURNACE	ST		111530028-001	5/8"		Copper	Copper
0624050105001	553		FURNACE	ST		111530056-001	5/8"		Copper	Copper
0624049105006	601		FURNACE	ST		112533042-001	5/8"		Copper	Copper
0624049104016	604		FURNACE	ST		112533004-008	5/8"	Copper	Copper	Copper
0624049104015	606		FURNACE	ST		112533008-001	5/8"		Copper	Copper
0624049105005	609		FURNACE	ST		112533046-001	5/8"		Copper	Copper
0624049104018	610		FURNACE	ST		112533012-001	5/8"	Copper	Copper	Copper
0624049105003	615		FURNACE	ST		112533054-002	5/8"		Copper	Copper
0624049104012	616		FURNACE	ST		112533016-006	5/8"		Copper	Copper
0624049104011	620		FURNACE	ST		112533024-001	5/8"		Copper	Copper
0624049104010	622		FURNACE	ST		112533028-001	5/8"		Copper	Copper
0624049104009	626		FURNACE	ST		112533032-002	5/8"		Copper	Copper
0624049105001	627		FURNACE	ST		112533064-002	5/8"		Copper	Copper
0624028108043	705		FURNACE	ST		124590250-001	5/8"		Copper	Copper
0624028108042	709		FURNACE	ST		124590254-001	5/8"		Copper	Copper
0624028105038	712		FURNACE	ST		124590210-001	5/8"		Copper	Galvanized
0624028108010	713		FURNACE	ST		124590258-001	5/8"		Copper	Copper
0624028105037	716		FURNACE	ST		124590214-006	5/8"		Copper	Copper
0624028108009	717		FURNACE	ST		124590262-001	5/8"		Copper	Copper
0624028105036	720		FURNACE	ST		124590216-001	5/8"		Copper	Copper
0624028108008	721		FURNACE	ST		124590266-001	5/8"		Copper	Copper
0624028105035	726		FURNACE	ST		124590220-002	5/8"		Copper	Copper
0624028108007	727		FURNACE	ST		124590270-003	5/8"		Copper	Copper
0624028105034	730		FURNACE	ST		124590224-001	5/8"		Copper	Copper
0624028108006	731		FURNACE	ST		124590274-005	5/8"		Copper	Copper
0624028105033	734		FURNACE	ST		124590228-001	5/8"		Copper	Copper
0624028108005	735		FURNACE	ST		124590278-001	5/8"		Copper	Copper
0624028105032	738		FURNACE	ST		124590232-001	5/8"		Copper	Copper

Property Parcel #	Address #	E/W	Street Name	Ext.	Description	Utility Account #	Meter Size	Public	Private	At meter
0624028108004	739		FURNACE	ST		124590282-001	5/8"		Copper	Copper
0624028105031	742		FURNACE	ST		124590234-001	5/8"		Copper	Copper
0624028108003	743		FURNACE	ST		124590288-001	5/8"		Copper	Copper
0624028105030	746		FURNACE	ST		124590238-001	5/8"		Copper	Copper
0624028108002	747		FURNACE	ST		124590292-001	5/8"		Copper	Copper
0624028105029	750		FURNACE	ST		124590240-001	5/8"		Copper	Copper

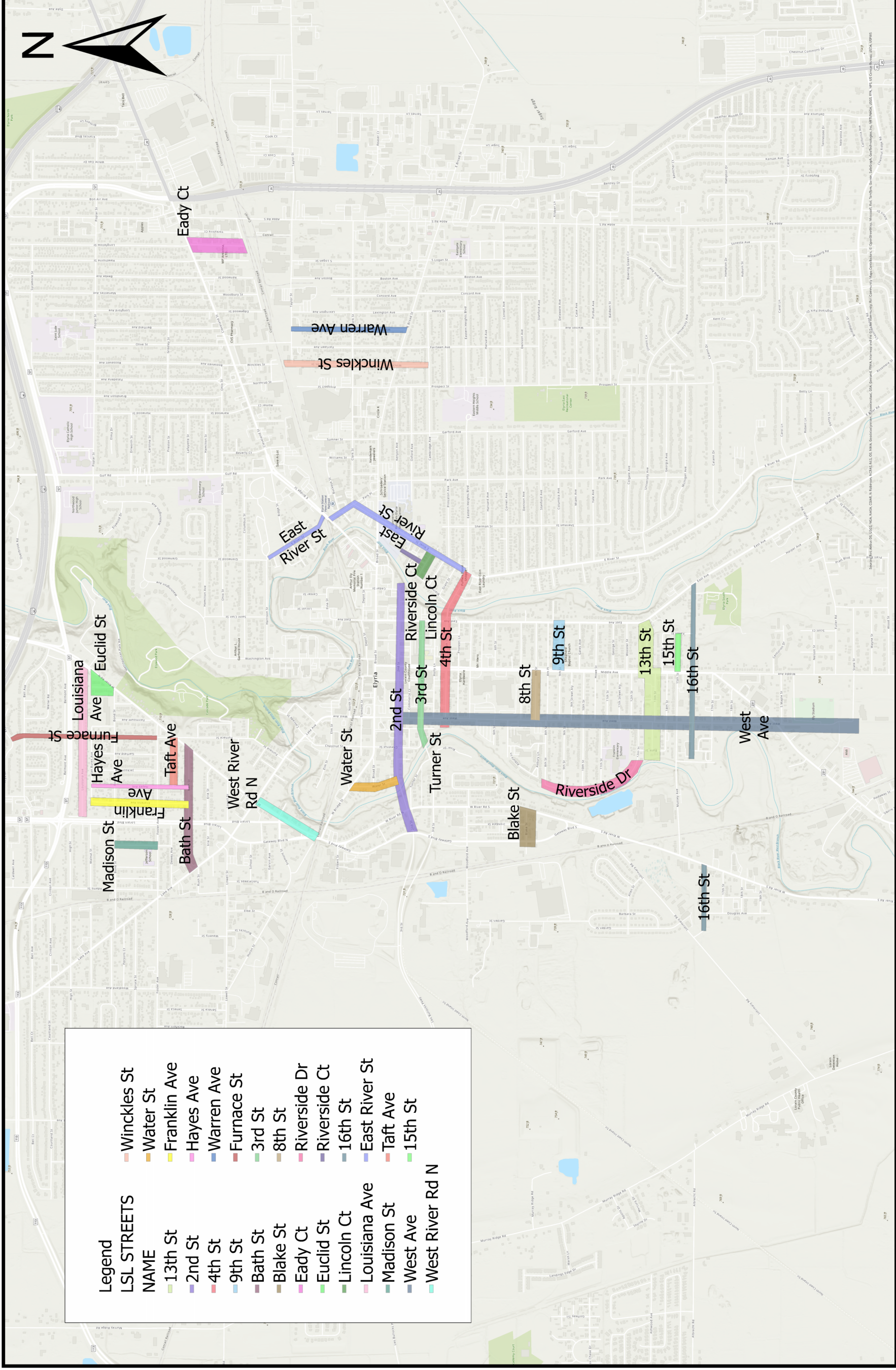

# LSL REPLACEMENT STREETS PHASE 4

TO BE USED FOR UTILITY COORDINATION. UTILIZE PHASE 4 ADDRESS LIST FOR SPECIFIC ADDRESS INFORMATION



## Contract Document Provisions

The following contract requirements and forms are to be included in the construction contract documents. Completed copies of the forms are to be submitted to Ohio EPA within one week after bids are received, or sooner dependent on your individual project schedule. Bid packages for WPCLF projects should be submitted to DEFA in the central office while bid packages for WSRLA projects should be submitted to the appropriate DDAGW district office.

### Equal Employment Opportunity (EEO) Requirements

The Contractor's EEO Certification Form must be (1) included in the contract documents and (2) referenced in the Instructions to Bidders, informing bidders that the form must be completed and submitted with their bid.

NOTE: If the loan applicant has its own EEO requirements, local procedures and forms may be substituted for the EPA form.

### Debarment

The Certification Regarding Debarment, Suspension, and Other Responsibility Matters must be (1) included in the contract documents and (2) referenced in the Instructions to Bidders, informing bidders that the form must be completed and submitted with their bid.

### Disadvantaged Business Enterprises (DBE) Utilization

The DBE Specification language and instructions to the bidders and Forms 6100-3, 6100-4 and 6100-2 must be (1) included in the contract documents and (2) referenced in the Instructions to Bidders, informing bidders that the forms must be completed and submitted with their bid.

NOTE: If the loan applicant has its own DBE requirements or if other funding programs with potentially competing DBE requirements are participating in the project funding, please contact Ohio EPA – DEFA for specific instructions regarding the DBE requirements.

### Davis-Bacon wage rate requirements

The contract documents must include language that requires contractors and subcontractors to pay wages at rates not less than those prevailing on similar projects within the area as determined by the US Secretary of Labor. In addition, the loan recipient will be required to conduct wage interviews and monitor payroll for compliance.

### Build America, Buy America (Lead Service Line, Emerging Contaminant, Equivalency Projects)

Build America Buy America Act (BABA) requirements apply to Lead Service Line, Emerging Contaminants and equivalency projects funded by a WPCLF assistance agreement and/or a WSRLA assistance agreement. Equivalency projects are those receiving funding from federal capitalization grants that support the WPCLF and WSRLA programs. The acknowledgement form must be included in the contract documents. The acknowledgement form should be signed by the contractor and submitted with the final bid package. It is recommended that the BABA guidance document and questions and answers document be included in the contract documents.

### *American Iron and Steel*

All treatment works projects funded by a WPCLF assistance agreement and all public water system projects funded by a WSRLA assistance agreement are required to comply with American Iron and Steel (AIS) requirements. The acknowledgement form must be included in the contract documents. The acknowledgement form should be signed by the contractor and submitted with the final bid package. It is recommended that the AIS guidance document and questions and answers document be included in the contract documents.

### *Bipartisan Infrastructure Law Signage Requirements*

The Bipartisan Infrastructure Law (BIL) mandates that recipients of BIL funding must install a sign in compliance with the design specifications provided by the United States Environmental Protection Agency (USEPA). These signs should be placed either on the construction site or in a location that is easily visible and directly relevant to the respective construction project. BIL-specific signage is applicable to all construction projects that receive funding under BIL, including those related to Lead Service Line, Emerging Contaminants, and equivalency projects.

Equivalency projects include projects that receive funding through federal capitalization grants supporting the Water Pollution Control Loan Fund (WPCLF) and the Water Supply Revolving Loan Account (WSRLA) programs. For all BIL-funded and equivalency projects, recipients are responsible for ensuring that a sign is prominently displayed at the construction site. This sign should feature the official “Investing in America” emblem and clearly identify the project as “funded by President Biden’s Bipartisan Infrastructure Law.”

These signs must be placed in locations that are easily visible, directly associated with the ongoing work, and they should be maintained in good condition throughout the entire construction period. Signage guidelines and design specifications provided by EPA for using the official Investing in America emblem are available at: <https://www.epa.gov/invest/investing-america-signage>.

The following contract requirements are to be included in the construction contract documents but are not required to be submitted to Ohio EPA for contract endorsement.

### *Violating Facilities Clause*

Language prohibiting this use of equipment or services from anyone on the EPA List of Violating Facilities must be included in the contract documents.

### *Small Businesses in Rural Areas (SBRA)*

Language encouraging the participation of small businesses in rural areas should be included in the contract documents.

### *Prohibition on Telecommunications and Video Surveillance*

Restrictions to loan recipients and subrecipients on certain telecommunications and video surveillance services or equipment due to Public Law 115-232.

[Insurance Provisions](#)

Section 3.5 of the WPCLF/WSRLA Loan Agreement contains specific requirements regarding insurance for all contractors and all subcontractors for the life of the contract. These insurance requirements must be reflected in the contract documents. Adjust the language as needed to meet the specifics of the construction project while still meeting the provisions of the Loan Agreement.

[Materials Testing](#)

In addition to the details included with specific equipment testing in the specifications, there should be an overall statement regarding testing for the project. Adjust the language as needed to meet the specifics of the construction project.

[Continuous Treatment Provisions](#)

It is important that construction activities not result in any temporary violations of Drinking Water or NPDES permit requirements (for permitted facilities). Construction activities should interrupt wastewater service to the individual resident as little as possible. For drinking water projects, it is important that construction activities not result in any disruption of service. The example language is intended for construction work occurring at an existing drinking water plant or a WWTP and must be adjusted to meet the specifics of the construction project.

[WPCLF/WSRLA Change Order Form](#)

All change orders for the construction project must be executed on the WPCLF/WSRLA change order form. The form must be (1) included in the contract documents and (2) the instructions referenced in the Contract Documents.

The following contract requirements are provided in Ohio Revised Code (ORC). Some loan applicants have local requirements that supersede ORC provisions for competitive bidding, and these local requirements can be applied instead of ORC, except for those requirements specified in the WPCLF/WSRLA loan agreements.

#### *Bid Guarantee*

The requirements for a bid guarantee (which can be a bond or a certified check, cashier's check, or letter of credit) are covered in ORC 153.54.

#### *Payment and Performance Bonds*

The requirements for a Payment and Performance Bond are covered in ORC 153.54 and Section 3.4 of the WPCLF/WSRLA Loan Agreements.

#### *Payment Retention*

The requirement for payment retainage is provided in ORC 153.12. Details on how the escrow account that holds the retainage are provided in ORC 153.13. Further details on how and when to pay for materials delivered and installed are provided in ORC 153.14.

#### *Completion Time*

The contract documents must state the length of the contract time per ORC 153.19. The dates for Initiation of Operation and Project Completion are specified in the WPCLF/WSRLA Loan Agreements and need to coincide with the specified contract time.

The following are contract provisions to consider but are not required. The language provided for each are samples only and must be adjusted to reflect the specifics of the project and local needs.

#### [Local Protest Procedure](#)

Some statement as to when a valid protest must be filed, in what form it must be filed and who it must be filed with should be included. ORC 153.12 has some default procedures for handling disputes. If the owner wants more control than provided in ORC, a procedure needs to be spelled out in the Contract Documents.

#### [Basis and Method for Award](#)

The contract documents should include some language that clearly states what the Owner will consider when determining the successful bidder and to provide a clear basis for the Owner when they have a need to reject the low bidder and go with a different bidder.

#### [Payment Methods](#)

To minimize uncertainty and arguments that can slow down the progress of construction it is useful to provide language stating how and when the Contractor will get paid. In addition to ORC and other local requirements, the involvement of public funding Agencies such as the WPCLF, WSRLA, Ohio Public Works Commission and Community Development Block Grant impact the process and timing for payments.

### **Contract Documents Review**

Whenever possible, all the provisions listed above must be included in the contract documents for the project prior to advertisement for bids. Ohio EPA's review for these contract provisions will occur as part of our normal detail plans and specifications review. The bidding documents are to be submitted to Ohio EPA for review regardless of whether a Permit to Install or a Plan Approval is required for the project.

#### *After bidding has started:*

In those cases when WPCLF or WSRLA funding is being requested after advertisement for bids has started, add all missing contract provisions, forms, and requirements via addendum.

#### *After bids have been opened but before contracts have been signed:*

If the bid advertisement period is over and bids have been opened, but the construction contract have not been signed yet, provide a draft contract change order which would be used to incorporate all missing contract provisions, forms, and requirements into the contract. This should be done in consultation with local legal counsel to address any potential bid protest concerns.

#### *Construction contracts have already been signed:*

If the construction contract has already been signed, a contract change order must be executed incorporating all missing contract provisions, forms, and requirements into the contract.

A [Contract Documents Review checklist](#) is provided here to help ensure that all requirements are included and to help expedite Ohio EPA's review of your documents.

### **Bid Package Submittals**

Certain documents must be submitted to Ohio EPA within one week after bids are received, or sooner dependent on your individual project schedule. Please [look here for a complete list](#) of the required submittals.

**NOTE: THE CONTRACT LANGUAGE SAMPLES PROVIDED HEREIN ARE EXAMPLES OF WHAT COULD BE INCLUDED IN ALL CONTRACTS THAT USE WPCLF OR WSRLA FUNDS. OHIO EPA MAKES NO CLAIMS REGARDING THE LEGALITY OF THESE CLAUSES WITH RESPECT TO STATE OR LOCAL LAW. IT IS IMPERATIVE THAT ANY PARTY INSERTING THESE CLAUSES INTO A CONTRACT VERIFY THAT THEY ARE LEGAL AND ENFORCEABLE ACCORDING TO STATE AND LOCAL LAWS, REGULATIONS, AND ORDINANCES.**



## Disadvantaged Business Enterprises (DBE) Utilization

USEPA has a program to encourage the participation of disadvantaged businesses in the construction activities funded by the Clean Water and Drinking Water SRF's. "DBE" is an all inclusive term that includes Minority Business Enterprises (MBE), Women Business Enterprises (WBE), Small Business Enterprises (SBE), Small Business in Rural Areas (SBRA), HUBZone Small Business, Labor Surplus Area Firms (LSAF), and other entities defined as socially and/or economically disadvantaged. While the WPCLF and WSRLA strongly encourage participation by all disadvantaged groups, specific participation goals are negotiated with USEPA only for Minority Business Enterprises and Women's Business Enterprises.

### Goals

As a condition of receiving capitalization grants from U.S. EPA for the Water Pollution Control Loan Fund (WPCLF) and the Water Supply Revolving Loan Account (WSRLA), the Ohio EPA negotiates "fair share" Disadvantaged Business Enterprises (DBE) objectives with U.S. EPA. The current negotiated goals for construction related activities are **1.3% of all contracts to MBEs and 1.0% of all contracts to WBEs.**

### DBE Certification

Under the DBE program, qualified DBE's are those that have been certified as an MBE or WBE. Certifications can be obtained from a federal agency such as the Small Business Administration or the Department of Transportation or by an approved State agency. The Unified Certification Program (UCP) administered by the Ohio Department of Transportation (ODOT) can provide the necessary DBE certifications. Information on the UCP can be found at <http://www.ohioucp.org> as well as the ODOT website [www.dot.state.oh.us/divisions/equalopportunity/pages/dbe.aspx](http://www.dot.state.oh.us/divisions/equalopportunity/pages/dbe.aspx).

### DBE Qualifications

To qualify for MBE certification, businesses must be 51 percent owned and controlled by a U.S. citizen and Ohio resident belonging to an African American, Native American, Hispanic, or Asian American ethnic group. In addition, the business must be in operation for at least one year prior to submitting an application. For DBE status, a business must be at least 51 percent owned by a socially and economically disadvantaged person who participates in the daily operations of the business. This person must be a woman or of African-American, Hispanic, Native American, Asian American ethnicity.

### Program Requirements

**To comply with DBE program requirements the WPCLF/WSRLA loan recipient must do the following:**

1. Create and maintain a bidder's list (see description below)

2. Include contract conditions applicable to the DBE program in all procurement contracts entered into by the Borrower for all WPCLF and WSRLA projects. These conditions are listed below.
3. Follow, document, and maintain documentation of good faith efforts on the part of prime contractors to ensure that Disadvantaged Business Enterprises (DBEs) have the opportunity to participate in the project.
4. Review the Form 6100-3 and 6100-4 submittals provided by bidders on the project for completeness and obtain any additional information necessary to verify the certification status of all proposed subcontractors.
5. Obtain documentation of the good faith efforts of the prime contractor if the prime contractor does not meet the MBE or WBE goal.
6. Obtain a written confirmation from any prime contractor states that they will not meet the MBE and WBE goals because they will not be entering into any agreements for goods or services with any company, firm, joint venture, or individual.
7. Submit the following to the Ohio EPA/DEFA as part of the bid package upon which the WPCLF/WSRLA loan amount is determined:
  - Form 6100-3 from each subcontractor
  - Form 6100-4 from each prime contractor
  - a copy of the Good Faith Efforts documentation from any prime contractors that will not meet the MBE and WBE goals,
  - if any of the prime contractors will not meet the MBE and WBE goals because they will not be entering into any agreements for goods or services with any company, firm, joint venture, or individual, a copy of the written confirmation from that prime contractor
8. Report MBE/WBE accomplishments on Form 5700-52A annually (within 15 days after October 1<sup>st</sup>).

**NOTE:** It is up to the WPCLF/WSRLA loan recipient whether or not to require completion and submission of Forms 6100-3 and 6100-4 from all bidders with the bid proposal or to accept completion and submission from the successful bidder(s) only at some time after bids are received. Regardless of whether the forms are completed and submitted with the bids or at some later time once the successful bidders are identified, completed forms are to be submitted to Ohio EPA with the bid package.

**To comply with DBE program requirements all prime contractors must do the following:**

1. Follow, document, and maintain documentation of their good faith efforts.
2. Complete and submit **Form 6100-4 DBE Subcontractor Utilization Summary** as part of the bid proposal package to the loan recipient.
3. Have its Disadvantaged Business Enterprise subcontractors complete **Form 6100-3 DBE Subcontractor Proposed Performance Form** and submit those as part of the bid proposal package to the loan recipient.
4. Provide **Form 6100-2 DBE Subcontractor Actual Participation Form** to all of its Disadvantaged Business Enterprise subcontractors for completion at the end of the work.
5. During construction, provide the data necessary so that the loan recipient can report MBE/WBE accomplishments on Form 5700-52A annually (within 15 days after October 1<sup>st</sup>).

## **Bidders List**

The Borrower must create, maintain, and use a bidders list for purposes of soliciting both MBE/WBEs and non-MBE/WBEs during procurement of construction, equipment, supplies, and services. This list shall include:

1. Entity's name with point of contact;
2. Entity's mailing address, telephone number, and e-mail address;
3. The procurement on which the entity bid or quoted, and when; and
4. Entity's status as an MBE/WBE or non-MBE/WBE.

Borrowers that receive less than \$250,000 or less in any one fiscal year can be exempt from maintaining a Bidders List.

The Bidders List shall be maintained until the project period has expired and the Borrower is no longer receiving EPA funding. The Bidders List must include all firms that bid on the prime contracts, or bid or gave a quote on subcontracts, including both MBE/WBEs and non-MBE/WBEs.

## **Required Contract Conditions**

The DBE Specification language and instructions to the bidders and Forms 6100-2, 6100-3 and 6100-4 must be included in the contract documents and referenced in the Instructions to Bidders, informing bidders that the forms must be completed and submitted with their bid for all WPCLF and WSRLA projects:

1. The prime contractor must pay its subcontractor for satisfactory performance no more than 30 days from the prime contractor's receipt of payment from the owner.
2. The prime contractor must notify the owner in writing prior to the termination of any Disadvantage Business Enterprise subcontractor for convenience by the prime contractor.
3. If a Disadvantage Business Enterprise contractor fails to complete work under the subcontract for any reason, the prime contractor must employ the six Good Faith Efforts (listed below) if soliciting a replacement contractor.
4. The prime contractor must employ the six Good Faith Efforts even if the prime contractor has achieved its fair share objectives.
5. An owner must ensure that each procurement contract it awards contains the following terms and conditions:

The contractor shall not discriminate on the basis of race, color, national origin or sex in the performance of this contract. The contractor shall carry out applicable requirements of 40 CFR Part 33 in the award and administration of contracts awarded under EPA financial assistance agreements. Failure by the contractor to carry out these requirements is a material breach of this contract which may result in the termination of this contract or other legally available remedies.

## **Good Faith Efforts**

Borrowers and their prime contractors must follow, document, and maintain documentation of their good faith efforts as listed below to ensure that Disadvantaged Business Enterprises (DBEs) have the opportunity to participate in the project by increasing DBE awareness of procurement efforts and outreach.

1. Ensure DBEs are made aware of contracting opportunities to the fullest extent practicable through outreach and recruitment activities; including DBEs on solicitation lists and soliciting them whenever they are potential sources.
2. Make information on forthcoming opportunities available to DBEs and arrange time frames for contracts and establish delivery schedules, where the requirements permit, in a way that encourages and facilitates participation by DBEs in the competitive process. This includes, whenever possible, posting solicitation for bids or proposals for a minimum of 30 calendar days before the bid or proposal closing date.
3. Consider in the contracting process whether firms competing for large contracts could be subcontracted with DBEs. This will include dividing total requirements when economically feasible into smaller tasks or quantities to permit participation by DBEs in the competitive process.
4. Encourage contracting with a consortium of DBEs when a contract is too large for one of these firms to handle individually.
5. Use the services and assistance of the Small Business Administration and the Minority Business Development Agency of the U.S. Department of Commerce.
6. If the prime contractor awards subcontracts, require the prime contractor to take the steps in numbers 1 through 5 above.

## **DBE Forms**

Form 6100-3 – Each prime contractor must have its DBE subcontractors complete **Form 6100-3 DBE Subcontractor Proposed Performance Form**. This form gives the DBE subcontractor the opportunity to report the scope and cost of the subcontract and it should be forwarded to the Prime Contractor along with the DBE's quote. Each subcontractor completes one Form 6100-3. The Borrower must submit all Form 6100-3 forms to the Ohio EPA/DEFA as part of the bid package upon which the WPCLF/WSRLA loan amount is determined.

Form 6100-4 – Each prime contractor must complete and submit **Form 6100-4 DBE Subcontractor Utilization Summary** as part of the prime contractor's bid proposal package to the Borrower. This form summarizes the Prime Contractor's intended use of identified DBE(s) and the estimated dollar amount of each subcontract. Only one Form 6100-4 form is required from each Prime Contractor. The Borrower must submit this form to the Ohio EPA/DEFA as part of the bid package upon which the WPCLF/WSRLA loan amount is determined.

Form 6100-2 - The prime contractor must provide **Form 6100-2 DBE Subcontractor Actual Participation Form** to all of its Disadvantaged Business Enterprise subcontractors.

This form gives the DBE subcontractor the opportunity to describe the work the DBE received from the Prime Contractor, how much the DBE was paid and any other concerns the DBE might have. Disadvantaged Business Enterprise subcontractors must send completed Form 6100-2 directly to the Region 5 DBE Coordinator after the work by the subcontractor is done and is NOT submitted with the bid package to Ohio EPA.

Region 5 MBE/WBE Coordinator  
USEPA, Acquisition and Assistance Branch  
77 West Jackson Boulevard (MC-10J)  
Chicago, IL 60604

## Reporting During Construction – Form 5700-52A

The purpose of MBE/WBE reporting is to monitor the grant recipient's accomplishments in utilizing MBEs and WBEs; and adherence to the good faith efforts (i.e., outreach to MBEs, WBEs, and other DBEs); and progress in achieving MBE and WBE Goals. During the progress of the construction project, the loan recipient must complete & submit Form 5700-52A annually (**within 15 days after October 1<sup>st</sup>**). If there were no MBEs or WBEs utilized, or no procurement expenditures of any kind were made during the reporting period, a "negative report" is still required.

Reports are to be sent to:

Florel Fraser, Ohio EPA – DEFA  
P.O. Box 1049  
Columbus, OH 43216-1049  
E-mail address: [Florel.Fraser@epa.ohio.gov](mailto:Florel.Fraser@epa.ohio.gov)  
Phone: (614) 644-3636

**Disadvantaged Business Enterprise (DBE) Program  
DBE Subcontractor Participation Form**

An EPA Financial Assistance Agreement Recipient must require its prime contractors to provide this form to its DBE subcontractors. This form gives a DBE<sup>1</sup> subcontractor<sup>2</sup> the opportunity to describe work received and/or report any concerns regarding the EPA-funded project (e.g., in areas such as termination by prime contractor, late payments, etc.). The DBE subcontractor can, as an option, complete and submit this form to the EPA DBE Coordinator at any time during the project period of performance.

Subcontractor Name		Project Name	
Bid/ Proposal No.	Assistance Agreement ID No. (if known)	Point of Contact	
Address			
Telephone No.		Email Address	
Prime Contractor Name		Issuing/Funding Entity:	

Contract Item Number	Description of Work Received from the Prime Contractor Involving Construction, Services , Equipment or Supplies	Amount Received by Prime Contractor

<sup>1</sup> A DBE is a Disadvantaged, Minority, or Woman Business Enterprise that has been certified by an entity from which EPA accepts certifications as described in 40 CFR 33.204-33.205 or certified by EPA. EPA accepts certifications from entities that meet or exceed EPA certification standards as described in 40 CFR 33.202.

<sup>2</sup> Subcontractor is defined as a company, firm, joint venture, or individual who enters into an agreement with a contractor to provide services pursuant to an EPA award of financial assistance.

**Disadvantaged Business Enterprise (DBE) Program  
DBE Subcontractor Participation Form**

Please use the space below to report any concerns regarding the above EPA-funded project:

---

---

---

---

---

---

---

---

---

---

---

---

---

---

---

---

---

<b>Subcontractor Signature</b>	<b>Print Name</b>
<b>Title</b>	<b>Date</b>

## ALERT

“Total Procurement” fields and “MBE/WBE Combined Procurement” fields located in section 4B of this form should include Federal funds provided under the assistance agreement, recipient matching funds, and funds from other sources that are included in the assistance agreement.

Due to process time of Paperwork Reduction Act procedures, EPA is not able to update the [EPA Form 5700-52A](#) immediately to reflect this clarification.

**If EPA grant recipients have questions about [EPA Form 5700-52A](#), please work with your respective Grants Specialist or [DBE Coordinator](#).**





## U.S. ENVIRONMENTAL PROTECTION AGENCY MBE/WBE UTILIZATION UNDER FEDERAL GRANTS AND COOPERATIVE AGREEMENTS

This collection of information is approved by OMB under the Paperwork Reduction Act, 44 U.S.C. 3501 et seq. (OMB Control No. 2030-0020). Responses to this collection of information are required to obtain an assistance agreement (40 CFR Part 30, 40 CFR Part 31, and 40 CFR Part 33 for awards made prior to December 26, 2014, and 2 CFR 200, 2 CFR 1500, and 40 CFR Part 33 for awards made after December 26, 2014). An agency may not conduct or sponsor, and a person is not required to respond to, a collection of information unless it displays a currently valid OMB control number. The public reporting and recordkeeping burden for this collection of information is estimated to be 1 hour per response. Send comments on the Agency's need for this information, the accuracy of the provided burden estimates and any suggested methods for minimizing respondent burden to the Regulatory Support Division Director, U.S. Environmental Protection Agency (2821T), 1200 Pennsylvania Ave., NW, Washington, D.C. 20460. Include the OMB control number in any correspondence. Do not send the completed form to this address.

<b>1A. REPORTING PERIOD</b> October 1, _____ – September 30, _____		<b>1B. REPORT TYPE</b> <input type="checkbox"/> Annual <input type="checkbox"/> Final Report (Project completed)													
<b>1C: Revision of a Prior Year Report?</b> <input type="radio"/> No <input type="radio"/> Yes If yes, what reporting period is being revised and briefly describe the changes made. <b>Note:</b> The revised report will replace the associated original report in its entirety.															
<b>2A. RECIPIENT UNIQUE ENTITY IDENTIFIER</b>  															
<b>2B. RECIPIENT REPORTING CONTACT</b> Name: Email: Phone:															
<b>3. FEDERAL AWARD IDENTIFICATION NUMBER (FAIN)</b> (For SRF state recipients, please include all numbers for all open assistance agreements being reported on this form.)															
<b>4A. If NO procurements were made this reporting period (by the recipient, sub-recipient(s), loan recipient(s), and prime contractor(s)), CHECK and SKIP to Block No. 6.</b> (Procurements are all expenditures through contract, order, purchase, lease or barter of supplies, equipment, construction, or services needed to complete Federal assistance programs.) <input type="checkbox"/>															
<b>4B. Total Procurements &amp; MBE/WBE Accomplishments This Reporting Period (in dollars)</b> <table style="width: 100%; border-collapse: collapse; margin-top: 10px;"> <thead> <tr> <th style="width: 60%;"></th> <th style="width: 20%; text-align: center;">Construction</th> <th style="width: 20%; text-align: center;">Non-Construction</th> <th style="width: 10%; text-align: center;">Total</th> </tr> </thead> <tbody> <tr> <td>Total Procurement:</td> <td style="text-align: center;">\$ _____</td> <td style="text-align: center;">\$ _____</td> <td style="text-align: center;">\$ _____</td> </tr> <tr> <td>MBE/WBE Combined Procurement:</td> <td style="text-align: center;">\$ _____</td> <td style="text-align: center;">\$ _____</td> <td style="text-align: center;">\$ _____</td> </tr> </tbody> </table>					Construction	Non-Construction	Total	Total Procurement:	\$ _____	\$ _____	\$ _____	MBE/WBE Combined Procurement:	\$ _____	\$ _____	\$ _____
	Construction	Non-Construction	Total												
Total Procurement:	\$ _____	\$ _____	\$ _____												
MBE/WBE Combined Procurement:	\$ _____	\$ _____	\$ _____												
<b>5A. Good Faith Efforts:</b> If procurements were made, indicate whether your organization has followed the six Good Faith efforts found in 40 CFR Part 33, Subpart C, 40 CFR 33.501 and 2 CFR 200.321.  <input type="checkbox"/> Yes, my organization has implemented and documented each of the six Good Faith Efforts on the procurements made during this reporting period.  <input type="checkbox"/> No, my organization has not implemented and documented each of the six Good Faith Efforts on the procurements made during this reporting period.		<b>5B. If procurements were made, but no MBE/WBE procurements are being reported, then check the applicable box(es) for the reason(s) why no MBE/WBE procurements were made.</b>  <input type="checkbox"/> No MBE/WBE(s) applied <input type="checkbox"/> No MBE/WBE(s) were qualified  <input type="checkbox"/> Other:													
<b>6. NAME OF RECIPIENT'S AUTHORIZED REPRESENTATIVE</b>		<b>TITLE</b>													
<b>7. SIGNATURE OF RECIPIENT'S AUTHORIZED REPRESENTATIVE</b>		<b>DATE</b>													

## **Instructions:**

### **A. General Instructions:**

MBE/WBE utilization is based on 40 CFR Part 33 and 2 CFR Parts 200 and 1500. The reporting requirement reflects the change in the reporting threshold described in Recipient/ Applicant Information Notice-2018-G04 issued by EPA's Office of Grants and Debarment on September 7, 2018 (<https://www.epa.gov/grants/rain-2018-g04>). EPA Form 5700-52A must be completed annually by recipients of financial assistance agreements where the combined total of funds budgeted for procuring supplies, equipment, construction and services exceeds the current Simplified Acquisition Threshold as set by the Federal Acquisition Regulation at 48 CFR Subpart 2.1. This reporting requirement applies to all new and existing awards and voids all previous reporting requirements.

In determining whether the threshold is exceeded for a particular assistance agreement, the analysis must focus on funds budgeted for procurement under the supplies, equipment, construction, services or "other" categories, and include funds budgeted for procurement under sub- awards or loans.

Reporting will also be required in cases where the details of the budgets of sub-awards/loans are not clear at the time of the grant awards and the combined total of the procurement and sub-awards and/or loans exceeds the Simplified Acquisition Threshold.

For example, if the Simplified Acquisition Threshold is \$250,000, then if a recipient has \$300,000 budgeted under procurement, then completion of this report is required.

When reporting is required, all procurement actions are reportable, not just the portion which exceeds the Simplified Acquisition Threshold.

If at the time of award the budgeted funds exceed the Simplified Acquisition Threshold but actual expenditures fall below, a report is still required.

If at the time of award, the combined total of funds budgeted for procurements in any category is less than or equal to the Simplified Acquisition Threshold and is

maintained below the threshold, no DBE report is required to be submitted.

Recipients are required to report 30 days after the end of each federal fiscal year (i.e. October 30th), per the terms and conditions of the financial assistance agreement.

Final reports are due October 30<sup>th</sup> or 120 days after the end of the project period, whichever comes first.

MBE/WBE program requirements, including reporting, are material terms and conditions of the financial assistance agreement. Failure to comply may lead to termination of the financial assistance agreement which is then reported to the OMB-designated integrity and performance system accessible through SAM (currently FAPIIS) pursuant to 2 CFR 200.339(b).

### **B. Submission:**

Recipients must submit completed forms to the point of contact associated with the awarding office for the applicable assistance agreement.

Information on specific points of contact for EPA's Headquarters and ten Regional Offices is located at:

<https://www.epa.gov/grants/frequently-asked-questions-disadvantaged-business-enterprises>

Questions regarding the completion of this form should be directed to the DBE Coordinator associated with the awarding office for the applicable assistance agreement. A list of the DBE Coordinators for each awarding office can be located here:

<https://www.epa.gov/grants/epa-dbe-program-coordinators>

### **c. Instructions:**

1A. Specify Federal fiscal year this report covers. The Federal fiscal year runs from October 1st through September 30th (**e.g. November 29, 2020 falls within Federal fiscal year 2021**)

1B. Specify report type. Check the annual reporting box if this is an annual report. If it is a final report, check the final report box to indicate if the project is completed.

1C. Indicate if this is a revision to a previous year and provide a brief description of the revision you are making including what reporting period is being revised. The revised report will replace the associated original report in its entirety.

2A. Provide your organization's Unique Entity Identifier. More information about Unique Entity Identifier, including its meaning, can be found in 2 CFR Part 25.

2B. Identify the name and contact information for the person located within the recipient organization that can be contacted if questions arise from this report.

3. Provide the Federal Award Identification Number (FAIN) assigned by EPA. A separate report must be submitted for each Assistance Agreement.

**\*For SRF recipients:** In box 3 list numbers for ALL OPEN Assistance Agreements being reported on this form.

4A. Self-explanatory. **Note:** Procurement means expenditures under the supplies, equipment, construction, services or "other" categories, and include funds expended for procurement under sub-awards or loans.

4B. Provide the total dollar amount (in dollars) of **ALL** procurements awarded this reporting period by construction, non-construction, and grand total by the recipient, sub-recipients, and SRF loan recipients, **including** MBE/WBE expenditures, not just the portion which exceeds the threshold. For example: Actual dollars for procurement from the procuring office; actual contracts let from the contracts office; actual goods, services, supplies, etc., from other sources including the central purchasing/ procurement centers).

Provide the total dollar amount (in dollars) of MBE/WBE procurements **ONLY** awarded this reporting period by construction, non-construction, and grand total by the recipient, sub-recipients, SRF loan recipients, and prime contractors not just the portion which exceeds the threshold.

**\*For SRF recipients only:** In 4B, please enter the total annual procurement amount under all of your SRF Assistance Agreements. The figure reported in this section is **not** directly tied to an individual Assistance Agreement identification number. **(SRF state recipients report state procurements in this section)**

5A. Self-explanatory.

5B. If procurements were made during this reporting period, but no procurements with MBE(s) or WBE(s) are being reported, then select the reason why. If "Other" is chosen, please fill in with the reason.

6. Self-explanatory.

7. Self-explanatory.

\*\*This data is requested to comply with provisions mandated by: statute or regulations (40 CFR Part 33 and/or 2 CFR Parts 200 and 1500); OMB Circulars; or added by EPA to ensure sound and effective assistance management. Accurate, complete data are required to obtain funding, while no pledge of confidentiality is provided.

## **Material Suppliers**

In October 2009, OEPA/DEFA made a clarification to their DBE Policy. If a Contractor subcontracts work and cannot meet the Goals with MBE/WBE Subcontractors, the Goals may be met by supplying equipment from MBE/WBE Suppliers.

Also, Contractors that do not subcontract work do not have to comply with the MBE/WBE requirements although all Contractors are strongly encouraged to break the work into subcontracts whenever feasible.

## **Violating Facilities Clause**

### **Violating Facilities:**

The Contractor agrees to comply with all applicable standards, orders or requirements under Section 306 of the Clean Air Act, 42 USC 1857 (h), Section 508 of the Clean Water Act, 33 USC 1368, Executive Order 11738, and EPA regulations, 40 CFR Part 32, which prohibits the use under non-exempt Federal contracts, grants, or loans of facilities included on the EPA List of Violating Facilities.

## **Requirement For Utilization Of Small Businesses In Rural Areas (SBRA)**

This procurement is subject to the EPA policy of encouraging the participation of small businesses in rural areas. It is EPA policy that recipients of EPA financial assistance awards utilize the services of small businesses in rural areas (SBRAs), to the maximum extent practicable. The objective is to assure that such small business entities are afforded the maximum practicable opportunity to participate as subcontractors, suppliers and otherwise in EPA-awarded financial assistance programs. This policy applies to all contracts and subcontracts for supplies, construction, and services under EPA grants or cooperative agreements. Small purchases are also subject to this policy.

This procurement is subject to the EPA policy of encouraging the participation of small business in rural areas (SBRAs).

## WPCLF Local Protest Procedure

### Protests

A protest based upon an alleged violation of the procurement requirement may be filed against the OWNER's procurement action by a party with an adversely affected direct financial interest. The protest shall be filed with the Mayor. The OWNER shall determine the protest. The OWNER may request additional information or a hearing in order to resolve the protest.

A protest shall be filed as early as possible during the procurement process, but must be received by the OWNER no later than one week after the basis of the protest is known or should have been known, whichever is earlier. If the protest is mailed, the protester bears the risk of nondelivery with in the required time period.

A protest must clearly present the procurement requirement being protested, the facts which support the protest, and any other information necessary to support the protest.

## **Continuous Treatment Provisions**

It is important that construction activities not result in any temporary violations of NPDES permit requirements (for permitted facilities) and construction activities should interrupt wastewater service to the individual resident as little as possible. For drinking water projects, it is important that construction activities not result in any disruption of service. Any disruption of service must be immediately reported to the Ohio EPA, Drinking Water Section of the appropriate district office.

### **Continuous Treatment (wastewater projects)**

Federal regulations prohibit by-passing of any sewage during construction operations. The Contractor will be responsible for providing any required temporary pumping facilities piping, etc., necessary to complete the project without any plant by-passing and continuous treatment must be provided at the same level during construction as existed prior to construction.

Unless otherwise previously or subsequently specified, the Contractor shall procure and pay for all permits, licenses, and approvals necessary for the execution of his Contract.

The Contractor shall comply with all laws, ordinances, rules, orders, and regulations relating to the performance of the work required to complete their Contract.

The following example language is a sample of what might be appropriate for construction work occurring at an existing drinking water treatment plant. The language actually incorporated into the contract documents must be adjusted to meet the specifics of the construction project.

### **Continuous Treatment (drinking water projects)**

The Contractor will be responsible for obtaining approval from Ohio EPA for use of temporary pumping facilities, piping and other items in order to complete the project without any plant by-passing. Continuous treatment must be provided at the same level during construction as existed prior to construction.

Unless otherwise previously or subsequently specified, the Contractor shall procure and pay for all permits, licenses, and approvals necessary for the execution of his Contract.

The Contractor shall comply with all laws, ordinances, rules, orders, and regulations relating to the performance of the work required to complete their Contract.



## **WPCLF/WSRLA Payments**

This project is funded in whole or in part by funds from the Water Pollution Control Loan Fund (WPCLF) or the Water Supply Revolving Loan Account (WSRLA) as administered by the Ohio EPA-DEFA and the Ohio Water Development Authority (OWDA). The Contractor shall comply with all requirements of these programs. The Owner shall be responsible for the progress payments to the Contractor if the Owner becomes ineligible for further payments due to circumstances which are of no fault of the Contractor. The monthly payments to vendors may be made through the Owner, the OWDA, or both as deemed by the Owner.

The time frame for payment of pay estimates by the Owner and/or Special Funding Agency(s) may be up to 60 calendar days from date of receipt of pay estimate from Engineer to Owner. Ohio EPA/DEFA must approve all change orders before the change order may be submitted for payment on a pay estimate.

State of Ohio  
 WATER POLLUTION CONTROL LOAN FUND (WPCLF) /  
 WATER SUPPLY REVOLVING LOAN ACCOUNT (WSRLA)

**CONTRACT CHANGE ORDER**

RECIPIENT \_\_\_\_\_ CHANGE ORDER NBR \_\_\_\_\_

LOAN NUMBER \_\_\_\_\_ CONTRACT \_\_\_\_\_

OWDA PROJECT No. \_\_\_\_\_ DATE \_\_\_\_\_

Description of Change:

The time provided for completion in the contract for the above items is (increased/decreased) by \_\_\_\_ calendar days.

RECOMMENDED BY: \_\_\_\_\_ DATE: \_\_\_\_\_  
 (Engineer)

APPROVED BY: \_\_\_\_\_ DATE: \_\_\_\_\_  
 (Recipient)

ACCEPTED BY: \_\_\_\_\_ DATE: \_\_\_\_\_  
 (Contractor)

\_\_\_\_\_  
 (Company)

Original Contract Amt	_____
Previous Changes (+ / --)	_____
This Change (+ / --)	_____
Adjusted Contract Amt	_____

**OWDA APPROVAL**  
 The above proposal is hereby accepted and I recommend that it be approved and made a part of the contract noted above. The approval does not constitute an increase in the total loan amount, but represents approval for the work.

Ohio EPA Acceptance	Chief Engineer
Date	Date

## **CHANGE ORDER INSTRUCTIONS:**

All Change Orders for this work, regardless of costs and whether Water Pollution Control Loan Fund (WPCLF) or Water Supply Revolving Loan Account (WSRLA) funding will be used to finance the changes, must be submitted to Ohio EPA for review.

### *Changes Requiring Prior Approval*

Any change which substantially modifies the Project Facilities as specified in the Ohio EPA approved Facilities Plan and Final Permit to Install or Final Plan Approval (when applicable) or alters the direct or indirect impact of the Project Facilities upon the environment must be incorporated into a Change Order. One copy of the Change Order prior to execution is to be submitted to Ohio EPA for review and prior approval of the acceptability of the change. "Prior to execution" means before the Change Order is signed by the Owner.

Ohio EPA will review the Change Order and inform the Owner of the technical, environmental and operational acceptability of the change, and give the Owner permission to proceed with the proposed work.

### *All Other Changes*

Change Orders not requiring prior approval as described above must be submitted to Ohio EPA within one (1) month of the time at which they are approved by the Owner. All change orders must be submitted electronically to dedicated change order email addresses for WPCLF and WSRLA projects.

### *Change Order Approval Process*

After the Change Order is executed, one (1) copy of the Change Order, including the supporting documentation, is to be sent electronically to Ohio EPA for final review.

The dedicated e-mail address for the electronic submittal of WPCLF Change Orders is [EPAWPCLFCO@epa.ohio.gov](mailto:EPAWPCLFCO@epa.ohio.gov).

The dedicated e-mail address for the electronic submittal of WSRLA Change Orders is [EPAWSRLACO@epa.ohio.gov](mailto:EPAWSRLACO@epa.ohio.gov).

After the Change Order is accepted and eligible costs determined, Ohio EPA will issue a letter informing the Owner and authorizing OWDA to disburse funds from Project Contingency for the work. The OEPA letter will be sent electronically along with a PDF of the WPCLF/WSRLA Change Order form which will be signed by all parties including Ohio EPA and OWDA.

### *Payments for Change Order Work*

The Owner is precluded from submitting to the OWDA payment requests for Eligible Project Costs associated with the Change Orders until such time as the Ohio EPA's approval of the Change Orders has been obtained.



November 3, 2022

**MEMORANDUM**

**SUBJECT:** Build America, Buy America Act Implementation Procedures for EPA Office of Water Federal Financial Assistance Programs

**FROM:** Radhika Fox  
Assistant Administrator

A handwritten signature in black ink, appearing to be "R. Fox", written over a horizontal line.

**TO:** EPA Regional Water Division Directors, Regions I – X  
EPA Office of Water Office Directors

**OVERVIEW**

The Biden-Harris Administration recognized the Nation’s critical need for infrastructure investment, championing the Bipartisan Infrastructure Law (BIL), which Congress passed on November 15, 2021 (also known as the Infrastructure Investment and Jobs Act (IIJA)). The BIL will provide an unprecedented level of federal investment in water and wastewater infrastructure in communities across America.

In Title IX of the IIJA, Congress passed the Build America, Buy America (BABA) Act, which establishes strong and permanent domestic sourcing requirements across all Federal financial assistance programs for infrastructure. The U.S. Environmental Protection Agency (EPA) Office of Water is honored to help lead the implementation of these provisions and is proud of its near decade of successful implementation of the American Iron and Steel (AIS) provisions for its flagship water infrastructure programs.

This is a transformational opportunity to build a resilient supply chain and manufacturing base for critical products here in the United States that will spur investment in good-paying American manufacturing jobs and businesses. EPA’s efforts to implement BABA will help cultivate the domestic manufacturing base for a wide range of products commonly used across the water sector but not currently made domestically. This will take time, and flexibility will be important to ensure that EPA can leverage critical water investments on time and on budget to protect public health and improve water quality.

## **IMPLEMENTATION**

Recognizing the opportunity and need for BABA implementation guidance, the Made in America Office (MIAO) of the Office of Management and Budget (OMB) published [Initial Implementation Guidance on Application of Buy America Preference in Federal Financial Assistance Programs for Infrastructure](#) (OMB Guidance M-22-11) on April 18, 2022. The guidance provides government-wide implementation direction for all Federal financial assistance programs for infrastructure. Despite the extensive guidance developed by MIAO, EPA's Office of Water infrastructure investment programs have received many questions that were not addressed in OMB Guidance M-22-11 or that require further clarification for EPA water infrastructure programs. The following questions and answers serve to supplement OMB Guidance M-22-11 with implementation procedures specific to EPA's relevant water infrastructure programs.

Section 70914(a) of the IIJA states when a Buy America preference under BABA applies: "Not later than... [May 14, 2022], the head of each Federal agency shall ensure that none of the funds made available for a Federal financial assistance program for infrastructure... may be obligated for a project unless all of the iron, steel, manufactured products, and construction materials used in the project are produced in the United States." Therefore, Federal financial infrastructure investments obligated on or after May 14, 2022, must comply with the BABA requirements. Absent a waiver, all iron, steel, manufactured products, and construction materials permanently incorporated into an infrastructure project subject to the BABA requirements must be produced in the United States. For many of EPA's Office of Water infrastructure investment programs, the vast majority of products permanently incorporated into construction, maintenance, or repair projects must comply with the BABA requirements, with the exception of select construction materials (cement and cementitious materials; aggregates such as stone, sand, or gravel; or aggregate binding agents or additives), which are specifically excepted by the BABA statute.

EPA's Office of Water implements many infrastructure investment programs subject to BABA requirements, including the following:

- Alaska Native Villages and Rural Communities Water Grant Program (ANV) (and any associated Interagency Agreements with the Indian Health Service)
- Clean Water and Drinking Water State Revolving Fund Programs (CW and DWSRF)
- Clean Water and Drinking Water Grants to U.S. Territories and the District of Columbia
- Clean Water Indian and Drinking Water Tribal Infrastructure Grant Set-aside (and any associated Interagency Agreements with the Indian Health Service)
- Coastal Wetlands Planning, Protection and Restoration Act, (CWPPRA) Programs
- Congressionally Directed Spending/Community Project Funding (also known as Community Grants)
- Geographic Programs<sup>1</sup>
- Gulf Hypoxia Program
- National Estuaries Program (CWA Section 320)

---

<sup>1</sup> Geographic Programs include: Great Lakes Restoration Initiative, Chesapeake Bay, San Francisco Bay, Puget Sound, Long Island Sound, Gulf of Mexico, South Florida, Lake Champlain, Lake Pontchartrain, Southern New England Estuaries, Columbia River Basin, Pacific Northwest

- 319 Nonpoint Source Management Program Implementation
- Reducing Lead in Drinking Water Grant Program (SDWA §1459B)
- Assistance for Small and Disadvantaged Communities Grants: Small, Underserved, and Disadvantaged Community Grant Program (SUDC), Emerging Contaminants in Small or Disadvantaged Communities (EC-SDC) and Drinking Water Infrastructure Resilience & Sustainability (SDWA §1459A)
- Sewer Overflow and Stormwater Reuse Municipal Grants (OSG)
- USMCA Implementing Legislation (Section 821 and Title IX, USMCA Supplemental Appropriations, 2020)
- U.S.-Mexico Border Water Infrastructure Program
- Voluntary School and Child Care Program Lead Testing and Remediation Grant Program (SDWA 1464(d))
- Water Infrastructure Finance and Innovation Act (WIFIA)

The questions and answers in this document apply to the implementation of BABA requirements for the Office of Water infrastructure programs listed above unless superseded by regulation, statute, or other applicable guidance. For many of the programs listed above which did not have domestic preference requirements prior to BABA, additional implementation details are pending or may be developed after the issuance of these procedures. In addition, EPA notes that more direction will be helpful to inform the determination and definition of domestic content in manufactured goods. Supplemental guidance on these and other issues, from either OMB or EPA, may be forthcoming. These implementation procedures may also apply to additional, unlisted EPA programs which may be required to apply BABA subsequent to publication of this memorandum (e.g., future funding programs which have been authorized, but not yet appropriated).

For more information on the BABA requirements, visit the EPA Office of Water’s dedicated website – <https://www.epa.gov/cwsrf/build-america-buy-america-baba> – or contact your funding authority (such as your grants officer, portfolio manager, or state contact). For information on approved waivers, visit <https://www.epa.gov/cwsrf/build-america-buy-america-baba-approved-waivers>. You may also email questions to [BABA-OW@epa.gov](mailto:BABA-OW@epa.gov).

This Implementation Procedures document is organized to provide responses to questions in the following topic areas:

• Section 1: General .....	4
• Section 2: Product Coverage .....	5
• Section 3: Co-funding .....	9
• Section 4: Waivers.....	10
• Section 5: Documenting Compliance .....	12
• Section 6: Programs with American Iron and Steel Requirements.....	16
• Section 7: Program-Specific Issues.....	17
• Appendix 1: Example Build America, Buy America (BABA) Act Construction Contract Language .....	22
• Appendix 2: Example Build America, Buy America (BABA) Act Assistance Agreement Language .....	23

# **QUESTIONS AND ANSWERS**

## **SECTION 1: GENERAL**

- Q1.1: Will EPA provide documentation for BABA for bid solicitations and suggested contract language? Will EPA provide suggested language for Assistance Agreements?
  - A1.1: See Appendix 1, which includes suggested language for construction contracts which addresses the BABA requirements. In addition to the language suggested in Appendix 1, EPA also recommends that assistance recipients prepare contract bid solicitation documents with a statement for the consulting engineers and construction firms as follows: “By signing payment application and recommending payment, Contractor certifies they have reviewed documentation for all products and materials submitted for payment, and the certifications are sufficient to demonstrate compliance with Build America, Buy America Act requirements.” In most cases, the assistance recipient’s representatives assume the responsibility for their clients to conduct due diligence on compliance with applicable domestic preference requirements.

All Federal Financial infrastructure assistance agreements subject to BABA must have a clause requiring compliance with the requirements. See Appendix 2 for example assistance agreement language.

- Q1.2: Would federally-financed infrastructure projects outside of the United States need to comply with the BABA requirements?
  - A1.2: No. According to the OMB Guidance (M-22-11), a “project” is defined as “...any activity related to the construction, alteration, maintenance, or repair of infrastructure in the United States.” Therefore, the BABA requirements are not implicated for infrastructure projects occurring outside of the United States, such as projects funded through the United States-Mexico-Canada Agreement with infrastructure activities occurring in Mexico or Canada (that is, outside the United States).
  -
- Q1.3: If most of the project is BABA compliant, and a small portion is not, can an assistance recipient self-fund (i.e., paying with non-federal dollars) the non-compliant products?
  - A1.3: Any project that is funded in whole or in part with federal assistance must comply with the BABA requirements, unless the requirements are otherwise waived. All iron, steel, manufactured products, and construction materials used in a project must meet the BABA requirements unless waived. Absent a waiver, there is no “small portion” or product that does not need to satisfy the BABA requirements unless the requirements are waived (or specifically excluded as is the case for cement and cementitious materials; aggregates such as stone, sand, or gravel; aggregate binding agents or additives; or non-permanent products). An assistance recipient may request a waiver or inquire as to whether a broad waiver, such as a *de minimis* waiver, might apply.

- Q1.4: How do international trade agreements affect the implementation of the BABA requirements?
  - A1.4: The BABA requirements apply in a manner consistent with United States obligations under international trade agreements. Typically, these obligations only apply to direct procurement by the entities that are signatories to these trade agreements. In general, assistance recipients are not signatories to such agreements, so these trade agreements have no impact on BABA implementation. In the few instances where such an agreement applies to a municipality, that municipality is responsible for determining its applicability and requirements and communicating with the funding authority (such as EPA and/or a state) on the actions taken to comply with BABA.

SECTION 2: PRODUCT COVERAGE

- Q2.1: For products made of iron and steel, what is the difference between predominantly and primarily iron and steel?
  - A2.1: EPA considers the terms “predominantly” and “primarily” to be interchangeable, such that a product is considered predominantly (or primarily) iron and steel if it contains greater than 50 percent iron and steel by material cost.
- Q2.2: What is the definition of construction materials (with examples)?
  - A2.2: From OMB Guidance M-22-11: “construction materials” include an article, material, or supply (other than an item of primarily iron or steel; a manufactured product; cement and cementitious materials; aggregates such as stone, sand, or gravel; aggregate binding agents or additives; or non-permanent products) that is or consists primarily of:
    - non-ferrous metals,
    - plastic and polymer-based products (including polyvinylchloride, composite building materials, and polymers used in fiber optic cables), (including optic glass),
    - lumber, and
    - drywall.

For example, a plate of glass would be a construction material under BABA, but a framed window that incorporates the glass into a frame would be a manufactured product. Another common construction material for water infrastructure projects would be polyvinyl chloride (PVC) pipe and fittings. However, if PVC components are incorporated into a more complex product such as instrumentation and control equipment or a water treatment unit, those items would be manufactured products.

- Q2.3: What are manufactured products (with examples)?
  - A2.3: From OMB Guidance M-22-11: “...all manufactured products used in the project are produced in the United States—this means the manufactured product was manufactured in the United States; and the cost of the components of the manufactured product that are mined, produced, or manufactured in the United States is greater than 55 percent of



the total cost of all components of the manufactured product, unless another standard for determining the minimum amount of domestic content of the manufactured product has been established under applicable law or regulation...”

The manufactured products category would cover the majority of potential water infrastructure products, including complex products made up of a variety of material types and components. For water infrastructure projects, common manufactured products would include, but not be limited to, pumps, motors, blowers, aerators, generators, instrumentation and control systems, gauges, meters, measurement equipment, treatment equipment, dewatering equipment, actuators, and many other mechanical and electrical items.

- Q2.4: Which category will valves fall under for BABA? Will it differ from the American Iron and Steel (AIS) requirements?
  - A2.4: For programs that are subject to BABA and AIS (SRF, WIFIA, and Community Project Funding), projects using valves should classify them as iron and steel products under BABA as long as their material cost is made up of more than 50 percent iron and/or steel. Valves with 50 percent or less iron and/or steel by material cost would be considered manufactured products under the BABA requirements.

In accordance with OMB Guidance M-22-11, an article, material, or supply should be classified into only one of the three categories: iron and steel, manufactured products, or construction materials. Under the AIS requirements, all valves made primarily of iron and steel (that is, those with iron and/or steel material cost greater than 50 percent) must comply with the AIS requirements. For BABA, EPA interprets Section IV of OMB Guidance M-22-11 to mean that iron and steel products are those items that are primarily iron and steel, the same as for the AIS requirements.

- Q2.5: Does EPA have a list of products to be classified as “Iron and Steel” under BABA?
  - A2.5: Although this list is not comprehensive, the following products were classified as AIS products if made primarily (more than 50 percent) of iron and/or steel by materials cost (for programs subject to both AIS and BABA, this list would be equivalent for “iron and steel” items or products under either requirement):

Products likely made “primarily” of iron and steel to be classified as <u>Iron and Steel</u> under BABA		
Lined and Unlined Pipe	Lined and Unlined Fittings	Tanks
Flanges	Pipe Clamps and Restraints	Structural Steel
Valves	Hydrants	Pre-Cast, Iron/Steel Reinforced Concrete (of all types, regardless of iron/steel content percentage)
Manhole Covers and other Municipal Castings	Access Hatches	Ballast Screens
Iron or Steel Benches	Bollards	Cast Bases
Cast Iron Hinged Hatches	Cast Iron Riser Rings	Catch Basin Inlets

Cleanout/Monument Boxes	Construction Covers and Frames	Curb and Corner Guards
-------------------------	--------------------------------	------------------------

Products likely made “primarily” of iron and steel to be classified as <u>Iron and Steel</u> under BABA		
Curb Boxes	Curb Openings	Curb Stops
Detectable Warning Plates	Downspout Shoes	Drainage Grates
Drainage Grate Frames and Curb Inlets	Inlets	Junction Boxes
Lampposts	Manhole Rings and Frames	Manhole Risers
Meter Boxes	Service Boxes	Steel Hinged Hatches
Steel Riser Rings	Trash Receptacles	Tree Grates
Tree Guards	Trench Grates	Valve Boxes
Valve Box Covers and Risers	Access Ramps	Aeration Pipes and Fittings (separate from aeration/blowers)
Angles	Backflow Preventers/Double Check Valves	Baffle Curtains
Iron or Steel Bar	Bathroom Stalls	Beam Clamps
Cable Hanging Systems	Clarifier Tanks	Coiled Steel
Column Piping	Concrete Reinforcing Bar, Wire, and Fibers	Condensate Sediment Traps
Corrugated Pipe	Couplings	Decking
Digester Covers	Dome Structures	Door Hardware
Doors	Ductwork	Expansion Joints
Expansion Tanks (diaphragm, surge, and hydropneumatics)	Fasteners	Fencing and Fence Tubing
Fire Escapes	Flanged Pipe	Flap Gates
Framing	Gate Valves	Generic Hanging Brackets
Grating	Ground Testing Boxes	Ground Test Wells
Guardrails	HVAC Registers, Diffusers, and Grilles	Joists
Knife Gates	Ladders	Lifting Hooks, J-bar, Connectors within, and Anchors for Concrete
Lockers	Man Baskets and Material Platforms	Manhole Steps
Mud Valves	Municipal Casting Junctions	Non-mechanical (aka stationary) Louvers and Dampers
Overhead Rolling Doors/ Uplifting Doors (manual open, no motor)	Pipe Connectors	Pipe Hangers
Pipe Piling (any type of steel piling)	Pipe Spool (pipe, flanges, connectors, etc.)	Pipe Supports
Pitless Adaptors	Pre-fab Steel Buildings/Sheds (simple structure, unfurnished)	Pre-stressed Concrete Cylinder Pipe (PCCP)
Railings	Reduced Pressure Zone (RPZ) Valves	Roofing
Service Saddles	Sheet Piling	Sinks (not part of eyewash systems)
Solenoid Valves	Stairs	Static Mixers
Stationary Screens	Surface Drains	Tapping Sleeves
Telescoping Valves	Tipping Buckets	Trusses
Tubing	Valve Stem Extensions	Valve Stems (excluding handwheels and actuators)

Wall Panels	Wall Sleeves/Floor Sleeves	Welding Rods
Well Casing	Well Screens	Wire
Wire Cloth	Wire Rod	Wire Rope and Cables

Q2.6: Does EPA have a list of products that could be made “primarily” of iron and steel but would be classified as “manufactured products” under BABA?

A2.6: Although this list is not comprehensive, the following products would be considered “manufactured products” under the BABA requirements, even if the item might be composed primarily of iron and steel by materials cost (Note: These items are not subject to the AIS requirements.):

Products likely made “primarily” of iron and steel to be classified as <u>Manufactured Products</u> under BABA		
Actuator Superstructures/ Support Structures	Aeration Nozzles and Injectors	Aerators
Analytical Instrumentation	Analyzers (e.g., ozone, oxygen)	Automated Water Fill Stations
Blowers/Aeration Equipment	Boilers, Boiler Systems	Chemical Feed Systems (e.g., polymer, coagulant, treatment chemicals)
Chemical Injection Quills	Chemical Injectors	Clarifier Mechanisms/Arms
Compressors	Controls and Switches	Conveyors
Cranes	Desiccant Air Dryer Tanks	Dewatering Equipment
Dewatering Roll-offs	Disinfection Systems	Drives (e.g., variable frequency drives)
Electric/Pneumatic/Manual Accessories Used to Operate Valves (such as electric valve actuators)	Electrical Cabinetry and Housings (such as electrical boxes/enclosures)	Electrical Conduit
Electrical Junction Boxes	Electronic Door Locks	Elevator Systems (hydraulic, etc.,)
Emergency Life Systems (including eyewash stations, emergency safety showers, fire extinguishers, fire suppression systems including sprinklers /piping/valves, first aid, etc.)	Exhaust Fans	Fall Protection Anchor Points
Fiberglass Tank w/Appurtenances	Filters (and appurtenances, including underdrains, backwash systems)	Flocculators
Fluidized Bed Incinerators	Galvanized Anodes/Cathodic Protection	Gear Reducers
Generators	Geothermal Systems	Grinders
Heat Exchangers	HVAC (excluding ductwork)	HVAC Dampers (if appurtenances to aerators/blowers)
HVAC Louvers (mechanical)	Intake and Exhaust Grates (if appurtenances to aerators/blowers)	Instrumentation
Laboratory Equipment	Ladder Fall Prevention Systems	Ladder Safety Posts
Lighting Fixtures	Lightning and Grounding Rods	Mechanical or Actuated Louvers/Dampers
Membrane Bioreactor Systems	Membrane Filtration Systems	Metal Office Furniture (fixed)

Meters (including flow, wholesale, water, and service connection)	Motorized Doors (unit)	Motorized Mixers
Motorized Screens (such as traveling screens)	Motors	Pelton Wheels
Pipeline Flash Reactors (similar to injectors)	Plate Settlers	Precast Concrete without Iron/Steel Reinforcement

Products likely made “primarily” of iron and steel to be classified as <u>Manufactured Products</u> under BABA		
Furnished Pre-fab Buildings (such as furnished with pumps, mechanics inside)	Presses (including belt presses)	Pressure Gauges
Pump Cans/Barrels and Strainers	Pumps	Mechanical Rakes
Safety Climb Cable	Sampling Stations (unless also act as hydrant)	Scrubbers
Sensors	Sequencing Batch Reactors (SBR)	Steel Shelving (fixed)
Slide and Sluice Gates	Spray Header Units	Steel Cabinets (fixed interior/furniture)
Supervisory Control and Data Acquisition (SCADA) Systems	Tracer Wire	Valve Manual Gears, Actuators, Handles
Voltage Transformer	Water Electrostatic Precipitators (WESP)	Water Heaters
Weir Gates		

- Q2.7: Is asphalt paving a covered product under BABA?
  - A2.7: No. EPA interprets Section 70917(c) of the IIJA to exclude asphalt from BABA requirements. Asphalt paving is a type of concrete composed of an aggregate material mixed with a binder (bitumen). EPA considers asphalt concrete to be excluded by section 70917(c) due to its similarities with cement and cementitious materials.

**SECTION 3: CO-FUNDING**

- Q3.1: If projects are co-funded with funding mechanisms that don’t require BABA, must the entire project comply with BABA?
  - A3.1: Yes. Any project that is funded in whole or in part with federal assistance must comply with the BABA requirements, unless the requirements are otherwise waived. A “project” consists of all construction necessary to complete the building or work regardless of the number of contracts or assistance agreements involved so long as all the contracts and assistance agreements awarded are closely related in purpose, time, and place. This precludes the intentional splitting of projects into separate and smaller contracts or assistance agreements to avoid BABA’s applicability on some portions of a larger project, particularly where the activities are integrally and proximately related to the whole. However, there are many situations in which major construction activities are clearly undertaken in separate phases that are distinct in purpose, time, or place, in which case, separate contracts or assistance agreements would carry separate requirements.

- Q3.2: How will project requirements be determined for co-funded projects subject to potentially different general applicability/programmatic waiver conditions (such as different adjustment period waivers)?
  - A3.2: OMB Guidance M-22-11 addresses cases with project co-funding from separate programs. EPA would apply the guidance’s “cognizant” program determination to projects that are co-funded with different general applicability/programmatic waivers. For instance, if a project were co-funded between WIFIA and SRF and the majority of the Federal funding for the project is from WIFIA, then WIFIA would be the “cognizant” program for application and determination of waivers. In that case, any conditions from an applicable WIFIA waiver would apply.

#### SECTION 4: WAIVERS

- Q4.1: Who may apply for a waiver and how do you apply?
  - A4.1: Assistance recipients and their authorized representatives may apply for a project-specific waiver. EPA does not accept waiver requests from suppliers, distributors, or manufacturers unless the assistance recipient endorses and submits the request on its own behalf to the funding authority. In the case where multiple programs are providing federal funds to the project, the assistance recipient should submit the waiver request to the cognizant program, the one providing the greatest amount of federal funds for the project. For information on applying for cost waivers, see questions 4.4 and 4.5. For information on the SRF program roles and responsibilities, see question 7.6.

Project-specific waiver requests should generally include: (1) a brief summary of the project, (2) a description and explanation of the need for the waiver for the product(s) in question, (3) a brief summary of the due diligence conducted in search of domestic alternatives (which could include correspondence between assistance recipient and supplier/distributors), (4) the quantity and materials of the product(s) in question, (5) all engineering specifications and project design considerations relevant to the product(s) in question, (6) the approximate unit cost of items (both foreign and domestic) in addition to an estimated cost of the materials and overall project, (7) the date any products will be needed on site in order to avoid significant project schedule disruptions, and (8) any other pertinent information relevant to EPA’s consideration of the waiver (e.g., if relevant for SRF projects: whether the project is designated as an equivalency project, the date the plans and specifications were submitted to the state, the date of construction initiation, expected date of project completion, any special considerations such as local zoning and building ordinances, seismic requirements, or noise or odor control requirements).

In the case of indirect federal assistance, such as the SRF programs, the state authority reviews and conveys the waiver request to EPA. States should submit waiver requests to the appropriate program waiver request inbox. For SRF projects, please use [CWSRFWaiver@epa.gov](mailto:CWSRFWaiver@epa.gov) or [DWSRFWaiver@epa.gov](mailto:DWSRFWaiver@epa.gov).

- Q4.2: Can an assistance recipient request a waiver based on a specification written for a specific brand or model of product (that is, a specification that names a branded item or model)?
  - A4.2: In most cases, performance-based specifications are expected and required for the majority of infrastructure projects funded by EPA’s financial assistance programs. In rare cases where “branded” or product-specific sourcing may be included in project specifications, it is suggested that the specifications include the item in question (that is, not simply a catalog page, but also materials of construction, sizing, quantities, and applicable engineering performance design characteristics for the project, etc.) in addition to the standard phrase “or equal.” For the purposes of product alternative market research, EPA will evaluate the BABA requirements based on performance-based engineering specifications for the product(s) in question. If the project’s specifications do not include performance-based specifications, or at least an “or equal” designation, EPA will base its research on an “or equal” designation using best professional judgment to the extent practicable.
  
- Q4.3: If a manufactured product is not readily available domestically, will EPA provide short-term “limited availability” product waivers?
  - A4.3: EPA will address the unavailability of domestic products through the waiver process, including potential national short-term waivers for specific products, if appropriate. To the extent practicable and with the intent to maximize domestic market and supply chain development, EPA intends to address issues of broad product unavailability with targeted, time-limited, and conditional waivers, as prescribed in OMB Guidance M-22-11. EPA will follow its robust and thorough product research processes (those put into place for the AIS requirements for the SRF and WIFIA programs and expanded for the new BABA requirements) to identify and determine those products for which proposed national/general applicability waivers may be appropriate.
  
- Q4.4: What information is needed when applying for a cost waiver under BABA?
  - A4.4: As part of the cost waiver request, the assistance recipient must demonstrate that implementation of the BABA requirements will increase the overall project cost more than 25 percent. Depending on the circumstances of the overall project cost increases, documentation to justify the cost waiver can vary but may include itemized cost estimates or bid tabulations comparing project costs with and without BABA implementation. Assistance recipients should begin assessing the potential cost impacts of the BABA requirements during the design phase of a project.
  
- Q4.5: Can administrative costs associated with tracking and verification of certifications be considered when determining if the cost of a project increases by 25 percent or more?
  - A4.5: Yes. Section 70914(b)(3) of the IIJA states that a waiver may be provided if the overall

cost of the project increases by more than 25 percent due to the “inclusion of iron, steel, manufactured products, or construction materials produced in the United States.” EPA interprets this to mean that the “inclusion” of the BABA-covered products could encompass reasonable administrative costs associated with complying with the BABA requirements, such as staff, contractor, and technological resources to collect and track BABA compliance documentation.

- Q4.6: How can assistance recipients and construction contractors address product delivery delays?
  - A4.6: Assistance recipients should reasonably plan for material procurement to account for known potential supply chain issues or extended lead times and shall notify the funding authority well in advance of the issues so that prompt attention can be given to explore options. Where extended lead times for compliant products are impacting project schedules and may significantly impact construction progress, timely communication with the funding agency is important. For products that are unavailable within a reasonable timeframe to meet the objectives and schedule of a project, EPA may consider a non-availability waiver with adequate justification. An assistance recipient would need to apply for the waiver and contact its funding authority (such as EPA and/or a state) to initiate the waiver process.

#### SECTION 5: DOCUMENTING COMPLIANCE

- Q5.1: Who will be responsible for BABA enforcement?
  - A5.1: Responsibility for BABA implementation applies at all levels, from manufacturers to suppliers and distributors, construction contractors, assistance recipients, and funding authorities.

The manufacturers have responsibility to provide adequate and accurate documentation of the products manufactured. If suppliers and distributors are involved, they are responsible for passing along compliance documentation for products supplied to projects that are subject to the BABA requirements.

The assistance recipient and their representatives are primarily responsible for ensuring the documentation collected for products used on the project is sufficient to document compliance with the BABA requirements.

The funding authority is responsible for providing oversight and guidance as needed to ensure the proper implementation of the requirements. The Uniform Grants Guidance (UGG) (Title 2 of the Code of Federal Regulations (CFR) Part 200) applies to many Federal financial assistance agreements that will include BABA requirements. The general provisions of 2 CFR Part 200 determine the responsible party for the grant funding authority.

For information on SRF program roles and responsibilities, see question 7.6. At all levels, where fraud, waste, abuse, or any violation of the law is suspected, the Office of Inspector General (OIG) should be contacted immediately. The OIG can be reached at 1-888- 546-8740

or [OIG\\_Hotline@epa.gov](mailto:OIG_Hotline@epa.gov). More information can be found at this website:  
<http://www.epa.gov/oig/hotline.htm>.

- Q5.2: When will the BABA requirements be assessed for compliance? Do assistance recipients need to have waivers for potential non-domestic products before assistance agreements are in place, at the time products are procured or products are incorporated into the project (i.e., used)?
  - A5.2: Compliance is assessed where the domestic product is used (or installed) at the project site. Proper compliance documentation, whether it is a BABA certification letter or a waiver, should accompany a product prior to its “use”, in accordance with Section 70914(a) of IIJA. This may occur prior to assistance agreements being in place but is not necessary. Additionally, communication of BABA requirements through appropriate Terms and Conditions in financial assistance agreements and in project solicitation and contract documents is key in ensuring all parties involved are informed of the requirements for the project before construction is underway.
  
- Q5.3: How can product compliance with the BABA requirements be demonstrated?
  - A5.3: Assistance recipients and their representatives should ensure that the products delivered to the construction site are accompanied by proper documentation that demonstrate compliance with the law and be made available to the funding authority upon request. The documentation may be received and maintained in hard copy, electronically, or could be embedded in construction management software. The use of a signed certification letter for the project is the most direct and effective form of compliance documentation for ensuring products used on site are BABA-compliant prior to their installation; however, other forms of documentation are also acceptable as long as collectively, the following can be demonstrated:
    - (1) Documentation linked to the project. For example, this can be in the form of the project name, project location, contract number, or project number.
    - (2) Documentation linked to the product used on the project. For example, description of product(s) (simple explanation sufficient to identify the product(s)), or an attached (or electronic link to) purchase order, invoice, or bill of lading.
    - (3) Documentation includes statement attesting that the products supplied to the assistance recipient are compliant with BABA requirement. Reference to the Infrastructure Investment and Jobs Act (“IIJA”) or the Bipartisan Infrastructure Law (BIL) are also acceptable. For iron and steel items under BABA, references to the American Iron and Steel (AIS) requirements are also acceptable and reciprocal with BABA for such items.
    - (4) Documentation that manufacturing occurred in the United States, which could include, for example, the location(s) of manufacturing for each manufacturing step that is being certified. It is acceptable for manufactured products to note a single point of manufacturing, documenting that the final point of manufacturing is in the United States. Note that each BABA category may require different determinations for



compliance.

- (5) Signature of company representative (on company letterhead and signature can be electronic). The signatory of the certifying statement affirms their knowledge of the manufacturing processes for the referenced product(s) and attests that the product meets the BABA requirements.

In addition to compliance documentation, assistance recipients or their representatives should also conduct a visual inspection of the product when it arrives to the project site, especially for iron and steel products which are often stamped with the country of origin. (Note: A country of origin stamp alone is not sufficient verification of compliance with BABA and assistance receipts should not rely on it to ensure compliance.)

EPA may develop alternative procedures for demonstrating compliance. Additional project- or program-specific instructions may be developed on a case-by-case basis in order to meet individual circumstances.

- Q5.4: Will EPA provide a form or template for tracking and documenting compliance?
- A5.4: EPA does not require a specified format for tracking or documenting compliance. Assistance recipients are free to develop any system (from simple to complex software) for tracking items used on the project and the accompanying compliance documentation, e.g., certification letters, applicable waivers, if it helps with implementation and compliance. Elements that may help with keeping track of compliance may include: product description, quantity required/used, product category (i.e., iron and steel, manufactured product, or construction material), status of obtaining certification letter, product cost, and whether the item might qualify as *de minimis*, or qualify under another applicable waiver.
- Q5.5: If a manufacturer claims to comply with the Buy American Act, does it also comply with BABA?
  - A5.5: No. With the exception of the AIS requirements – which EPA interprets to be equivalent to the “iron and steel” requirements under BABA – EPA does not have an interpretation about the comparability of other domestic preference requirements relative to BABA. Any products that are to be certified as compliant with BABA should include a specific reference to the BABA requirements and appropriate attestation from a responsible manufacturing company official. See Question 5.3 for EPA’s recommendations for BABA certification letters.
- Q5.6: How will assistance recipients manage certification letters for hundreds, possibly thousands of products?

A5.6: EPA recognizes that the new BABA requirements will cover most products used in typical water and wastewater infrastructure projects, and that the number of items which may require certification at large and/or complex projects may reach several hundred. EPA is concerned about the potential administrative burden that this would place on assistance recipients. EPA recommends that projects with a high number of potentially covered

products meet with their funding authority about potential compliance strategies to minimize burden and streamline compliance activity. Assistance recipients should prepare contract bid solicitation documents with a statement for the consulting engineers and construction firms as follows: “By signing payment application and recommending payment, Contractor certifies they have reviewed documentation for all products and materials submitted for payment, and the documentation is sufficient to demonstrate compliance with Build America, Buy America Act requirements.” In most cases, the assistance recipient’s representatives may assume the responsibility for their clients to conduct due diligence on compliance with applicable domestic preference requirements.

- Q5.7: Who is responsible for documenting the 55 percent content requirement for manufactured products under BABA? What if the final manufacturer cannot trace or verify domestic origin for all components?
  - A5.7: The manufacturer who signs a certification letter is responsible for documenting compliance with any of the three categories of products (iron and steel, manufactured products, or construction materials). For manufactured products, BABA requires that greater than 55 percent of the total cost of all components of the manufactured product be from domestic sources. EPA recommends that the certification letter for manufactured products document whether the item passes the content test in the final product along with a statement attesting to compliance with the BABA requirements for manufactured products.
- Q5.8: How do final product fabricators document compliance when the final step of manufacturing may be simply assembling components?
  - A5.8: It is acceptable, in many cases, especially for highly complex manufactured products that utilize many sub-components, for the final point of assembly to certify without using a “step certification” process. Multiple certifications (i.e., step certifications) or a singular certification can be used for a product, as long as the certifying official is willing to attest to the product’s compliance with BABA requirements at all stages of manufacturing.
- Q5.9: Will Material Test Reports be acceptable in lieu of a BABA certification for iron and steel?
  - A5.9: Material Test Reports (MTRs, commonly referred to as “Mill Certifications” or “Mill Certs”) provide the chemical composition of steel and iron from a mill or foundry. If an MTR accompanies the delivery of steel or iron to a project site with an invoice or bill of lading, EPA will consider it sufficient to demonstrate compliance (equivalent to a certification letter) as long as the MTR includes a manufacturer representative’s signature in addition to the location (city and state) of the mill/foundry. It is common for MTRs to be the first letter in a “step certification” if the product is further fabricated or painted, etc., by another manufacturer.
- Q5.10: Can a manufacturer use a fillable certification letter for products?

- A5.10: EPA recommends that certifications be signed by representatives of the manufacturing entity. EPA does not oppose manufacturers using forms to internally develop letters within their company, thereby providing signed, non-manipulable certification letters to suppliers, distributors, and/or assistance recipients. A fillable form that can be changed by someone outside of the manufacturer after signature does not demonstrate compliance and may create compliance concerns for the manufacturer or assistance recipient.
- Q5.11: Are product certifications from suppliers and distributors allowed?
  - A5.11: EPA recommends that representatives of product manufacturers certify compliance and discourages suppliers and distributors from creating certification letters. EPA does not rule out the possibility that a third-party certification process, such as a certification by a distributor, may be viable. However, EPA is currently not aware of a system or proposed system that meets the EPA’s recommendations for documentation of product certification.
- Q5.12: How long should assistance recipients keep compliance documentation?
  - A5.12: Assistance recipients should apply recordkeeping requirements for the project according to the procedures dictated by the funding authority. For most EPA grant programs, this is prescribed in the UGG at 2 CFR 200.334-200.338; e.g., the SRF programs require a minimum of three years. Other funding programs may require longer documentation retention periods.

**SECTION 6: PROGRAMS WITH AMERICAN IRON AND STEEL REQUIREMENTS**

- Q6.1: Does BABA supersede the American Iron and Steel (AIS) Requirements?
  - A6.1: The BABA requirements for items considered “iron and steel” are equivalent to those for covered iron and steel products under the AIS requirements in the Clean Water Act and the Safe Drinking Water Act. These requirements apply to the CWSRF, DWSRF, WIFIA, and Water infrastructure Community Grants. BABA includes a “Savings Provision” (Section 70917(b)) that states that BABA does not affect existing domestic content procurement preferences for infrastructure projects funded by Federal financial assistance programs that meet the requirements of section 70914. EPA views the AIS requirements as meeting the “iron and steel” product requirements of BABA Section 70914, as they both include the key requirement that items made of iron and steel be wholly manufactured in the United States from the point of melting and/or pouring the iron or steel components through final manufacturing step. Because of the “Savings Provision” of Section 70917, the AIS requirements satisfy the “iron and steel” requirements of BABA. For the programs that have AIS requirements, EPA intends to implement BABA requirements the same way for iron and steel items as it has done for AIS products.

- Q6.2: For iron and steel products, does a manufacturer need to demonstrate compliance from initial melting through the finished product?
  - A6.2: For iron and steel products, the BABA requirements are the same as the existing AIS requirements, in that all of the iron and steel in a covered product (that is, the product is comprised of more than 50 percent iron and steel by material cost) must be melted and poured in the United States and all subsequent manufacturing processes (such as grinding, rolling, bending, reheating, and casting) must occur in the United States.

Q6.3: Will EPA apply the same manufacturing standards for BABA iron and steel products as for the American Iron and Steel (AIS) requirements?

- A6.3: Yes. For AIS, EPA did not require raw materials used in the production of steel or iron to be domestically sourced. For BABA, EPA interprets the requirements to be the same. Hence, like AIS, raw materials in the production of iron and steel subject to BABA requirements would not need to be domestically sourced. The key step for both AIS and BABA domestic iron and/or steel production is the melting/pouring (that is, the location of the furnace), which must be in the United States.
- Q6.4: Will the certification process be similar to the process established for the American Iron and Steel requirements?
  - A6.4: EPA expects the certification process for the BABA requirements to be very similar to that established for the AIS requirements. For iron and steel products, the process should remain the same for AIS and BABA. EPA recommends for manufactured products and for construction materials that certification letters include direct reference to the product/material content requirements under BABA, in addition to an affirmative statement verifying that the product meets the BABA requirements.
- Q6.5: Will duplicate certification letters be required for AIS and BABA for iron/steel products?
  - A6.5: No. Compliance with BABA requirements will be sufficient to demonstrate compliance with AIS requirements for iron and steel products. If a project is subject to BABA, the only demonstration of compliance necessary is with the BABA requirements, of which the iron and steel requirements are equivalent to those of the AIS statutory requirements: the iron or steel in a product made primarily or predominantly of iron and steel (comprising more than 50 percent iron and steel by material cost) must be melted and/or poured in the United States and all subsequent manufacturing processes must occur in the United States.

#### SECTION 7: PROGRAM-SPECIFIC ISSUES

- Q7.1.: How do the BABA requirements apply to Community Grants?
  - A7.1: The Community Project Funding/Congressionally Directed Spending grants for the construction of drinking water, wastewater, and stormwater infrastructure and for water

quality protection are subject to the requirements specified in the explanatory statement accompanying the Consolidated Appropriations Act (Explanatory Statement for Division G of P.L. 117-13, the Consolidated Appropriations Act of 2022). The explanatory statement asserts: “Applicable Federal requirements that would apply to a Clean Water State Revolving Fund or Drinking Water State Revolving Fund project grant recipient shall apply to a grantee receiving a CPF grant under this section.” Therefore, the federally funded Community Project Funding/Congressionally Directed Spending grants are subject to the same requirements that apply to CWSRF or DWSRF projects, including BABA and AIS requirements. See also A1.2.

- Q7.2: Should SRF projects covered by the BABA SRF Projects Design Planning Adjustment Period Waiver follow the same procedures for demonstrating compliance as outlined for American Iron and Steel requirements?
  - A7.2: Yes. The SRF Design Planning Adjustment Period waiver does not waive the iron and steel requirements under BABA. The SRF programs have existing domestic preference requirements for SRF projects under CWA Section 608 and SDWA Section 1452(a)(4) (AIS requirements) to use iron and steel products that are produced in the United States. Sections 70917(a) and (b) of BIL explain the application of BABA to existing domestic preference requirements. Specifically, the savings provision in Section 70917(b) states that existing domestic preference requirements that meet BABA requirements are not affected by BABA. The statutory AIS requirements were existing at the time BABA became law and satisfy the BABA iron and steel requirements. Therefore, the statutory AIS requirements that have previously applied to SRF-funded projects will continue to do so, and compliance with AIS requirements will satisfy the BABA iron and steel requirements. Demonstration of compliance for iron and steel products will follow the AIS implementation policies for projects subject to the waiver.
- Q7.3: For SRF programs, is BABA considered a federal cross-cutting authority? (i.e., do “equivalency” rules apply?)
  - A7.3: Yes, BABA is considered a federal cross-cutting requirement that applies to SRF assistance equivalent to the federal capitalization grant (i.e., “equivalency” projects). EPA’s SRF regulations at 40 CFR 35.3145 and 35.3575 require states and recipients of SRF funds equivalent to the amount of the federal capitalization grant to comply with federal cross-cutting requirements. Section 70914 of the IIJA, which states when a Buy America preference applies, explains that “none of the funds made available for a Federal financial assistance program for infrastructure...may be obligated for a project unless all of the iron, steel, manufactured products, and construction materials used in the project are produced in the United States.” Therefore, BABA only applies to projects funded in an amount equivalent to the federal capitalization grant and not to those projects receiving funds in excess of the capitalization grant (i.e., “non-equivalency” projects). (Note: The AIS requirements continue to apply for all SRF projects, including non-equivalency projects, and all WIFIA and Community Grant projects, because equivalency does not apply.)

- Q7.4: Do the BABA requirements apply to Drinking Water State Revolving Fund set-asides?
  - A7.4: Due to requirements related to the deposit of funds in the DWSRF program, almost all of the funds used to conduct set-aside activities are Federal dollars. Therefore, Federal cross-cutting requirements must be applied to all set-aside activities. However, in the case of most set-aside activities, the cross-cutting requirements will not be implicated because of the nature of the activities conducted under the set-asides. Because the BABA requirements only apply to infrastructure, and infrastructure typically is not an eligible set-aside expenditure (with one potential exception being loans for incentive-based source water protection measures under the Local Assistance and Other State Programs Set-Aside), the BABA requirements will not apply to most set-aside activities.
  
- Q7.5: What if an SRF project is refinanced using Federal financial assistance on or after May 14, 2022?
  - A7.5: If an SRF project began construction, financed from another funding source, prior to May 14, 2022, but is refinanced through an assistance agreement executed on or after that date, BABA requirements will apply to all construction that occurs on or after May 14, 2022, through completion of construction, unless a waiver applies. There is no retroactive application of the BABA requirements where a refinancing occurs for an SRF project that has completed construction prior to May 14, 2022. (Note: If SRF funding is used for the refinancing, the AIS requirements may still apply depending on the timing of construction.)
  
- Q7.6: What are the roles and responsibilities for SRF programs for BABA implementation?
  - A7.6: Implementation of the BABA requirements for the State Revolving Fund programs will continue the roles and responsibilities from the successful AIS implementation process.

As with AIS, it is both the assistance recipient's and the state's responsibility to ensure compliance with the BABA requirements. The state is the recipient of a federal capitalization grant and must comply with all grant conditions, including a condition requiring adherence to BABA requirements.

Consequently, states are strongly advised to conduct site visits of projects during construction and review documentation demonstrating the assistance recipient's proof of compliance. In EPA's experience, most states conduct periodic site visits and arrange timely meetings with funded projects. Observed best practices typically include a meeting early in the process (sometimes before bid and usually prior to commencing construction) and at least one project site visit during the construction process. Assistance recipients must maintain documentation of compliance with the BABA requirements, as explained in question 5.3. The documents must be kept by the assistance recipient and should be reviewed by the state during project reviews.

The state's role in the waiver process is to review any waiver requests submitted to the state to ensure that all necessary information has been provided by the assistance recipient prior to forwarding the request to EPA. If a state finds the request lacking, the state should work with

the assistance recipient to help obtain complete information. Question 4.1 explains the information needed by EPA to expediently review a waiver request.

In order to implement the BABA requirements, EPA has developed an approach for effective and efficient implementation of the waiver process to allow projects to proceed in a timely manner. The framework described below will allow states, on behalf of the assistance recipients, to apply for waivers of the BABA requirements directly to EPA Headquarters. Only waiver requests received and/or endorsed from states will be considered. Pursuant to BABA, EPA has the responsibility to make findings as to the issuance of waivers to the BABA requirements.

#### Step-by-step SRF Waiver Process

The waiver process begins with the assistance recipient. To fulfill the BABA requirements, the assistance recipient must in good faith design the project (where applicable) and solicit bids for construction with American-made iron and steel, manufactured goods, and construction materials. It is essential that the assistance recipient include the BABA terms in any request for proposals or solicitations for bids, and in all contracts (see Appendix 2 for sample construction contract language). The assistance recipient may receive a waiver at any point before, during, or after the bid process, if one or more of three statutory conditions is demonstrated to EPA and approved.

To apply for a project-specific waiver, the assistance recipient should email the request in the form of a Word document (.doc) or editable PDF (.pdf) to the funding program. It is strongly recommended that each state identify a person or persons for BABA communications. The state designee(s) will review the application for the waiver and determine whether the necessary information has been included (Note: More information may be provided in the future regarding what information is required to be included in waiver requests). Once the waiver application is complete, the designee (State) will forward the application to the EPA for review.

#### Evaluation by EPA

After receiving an application for waiver of the BABA requirements and ensuring sufficient information was provided, EPA will publish the request on its website for 15 days and receive public comment. EPA will then determine whether the application properly and adequately documents and justifies the statutory basis cited for the waiver.

In the event that EPA finds that adequate documentation and justification has been submitted, the Administrator may grant a waiver to the assistance recipient. EPA will notify the state designee whether a waiver request has been approved or not approved as soon as such a decision has been made. Granting such a waiver is a four-step process:

1. Research – After receiving an application for a waiver, EPA will perform market research to determine whether the iron, steel, manufactured goods, or construction materials are available domestically.
2. Posting – After research, if no domestic product has been identified, EPA is required to

publish the application and all material submitted with the application on EPA's website for 15 days. During that period, the public will have the opportunity to review the request and provide informal comment to EPA. The website can be found at: <https://www.epa.gov/cwsrf/build-america-buy-america-baba-waivers-open-public-comment>.

3. Evaluation – After receiving an application for waiver of the BABA requirements, EPA will determine whether the application properly and adequately documents and justifies the statutory basis cited for the waiver to determine whether or not to grant the waiver.

4. Signature of waiver approval by the Administrator or another agency official with delegated authority – As soon as the waiver is signed and dated, EPA will notify the State SRF program and post the signed waiver on the Agency's website. The assistance recipient should keep a copy of the signed waiver in its project files.

(Note: Additional steps may be required in the future regarding the waiver process depending on additional guidance from OBM) APPENDIX 1





UNITED STATES ENVIRONMENTAL PROTECTION AGENCY  
WASHINGTON, D.C. 20460

OFFICE OF WATER

December 8, 2022

**MEMORANDUM**

**SUBJECT:** Guidelines for Implementing the Bipartisan Infrastructure Law Signage Term and Condition for the State Revolving Fund Programs

**FROM:** Raffael Stein, Director  
Water Infrastructure Division

Raffael Stein

Digitally signed by Raffael  
Stein  
Date: 2022.12.08  
17:45:20 -05'00'

Anita Maria Thompkins, Director  
Drinking Water Infrastructure Development Division

ANITA THOMPKINS  
Digitally signed by ANITA  
THOMPKINS  
Date: 2022.12.08  
14:41:14 -05'00'

**TO:** Water Division Directors  
Regions I-X

The United States Chief Financial Officers (CFO) Council recently issued a Controller Alert titled, [“Enhancing Transparency Through the Use of the Building a Better America Emblem on Construction Signs.”](#) The Controller Alert informs federal agencies of the availability of the *Building a Better America* emblem and provides strategies for emblem use to increase the transparency of projects funded in whole or in part by the Infrastructure Investment and Jobs Act (IIJA), also referred to as the Bipartisan Infrastructure Law (BIL). In response to this Controller Alert, EPA’s Office of Grants and Debarment developed a term and condition that EPA must include in all fiscal year FY 2022 – 2026 Clean Water and Drinking Water State Revolving Fund (SRF) BIL capitalization grant awards. Regions must amend already-awarded BIL capitalization grants to include the new term and condition and include it in new BIL capitalization grants going forward.

For applicable projects (see next paragraph), the BIL signage term and condition will substitute for the existing SRF signage term and condition that implements the June 2015 policy, [“Guidelines for Enhancing Public Awareness of SRF Assistance Agreements.”](#) In other words, only the BIL-specific signage term and condition will apply to the applicable projects. The existing June 2015 SRF signage term and condition will continue to apply to equivalency projects funded with non-BIL (i.e., base) SRF capitalization grants. Although the 2015 signage requirement does not apply to BIL-funded SRF projects, we recommend that states encourage all borrowers/projects to notify the public of the benefits of the projects and the role of the SRF, using one of the options included in the June 2015 policy memorandum.

The BIL signage term and condition requires a physical sign displaying the official *Building a Better America* emblem and EPA logo be placed at construction sites for BIL-funded projects. For the Clean Water and Drinking Water SRF programs, this requirement applies only to the following projects:

- Construction projects identified as “equivalency projects” for BIL general supplemental capitalization grants;
- Construction projects that receive additional subsidization (grants or forgivable loans) made available by BIL general supplemental capitalization grants;
- All construction projects funded with BIL emerging contaminants capitalization grants;
- All construction projects funded with BIL lead service line replacement capitalization grants.

States must ensure that assistance recipients for which this requirement is applicable are aware of the requirement and the signage specifications. States must include this requirement in applicable assistance agreements. Additional details and specifications are included in the attached term and condition.

The sign must be placed at construction sites in an easily visible location that can be directly linked to the work taking place and must be maintained in good condition throughout the construction period. In cases where the construction site covers a large area (e.g., lead service line replacement or septic tank repair/replacement projects), a sign should be placed in an easily visible location near where the work is being performed (e.g., entrance to the neighborhood, along a main road through town, etc.). Signage costs are considered an allowable SRF expense, provided the costs associated with the signage are reasonable. Additionally, to increase public awareness of projects serving communities where English is not the predominant language, assistance recipients are encouraged to translate the language on signs (excluding the official Building a Better America emblem or EPA logo or seal) into the appropriate non- English language(s). The costs of such translation are allowable SRF expenses, provided the costs are reasonable.

Inquiries may be directed to Josh Amaris at [Amaris.Josh@epa.gov](mailto:Amaris.Josh@epa.gov) and Nick Chamberlain at [Nick.Chamberlain@epa.gov](mailto:Nick.Chamberlain@epa.gov).

Attachment

Cc: Region I-X Branch Chiefs  
Region I-X SRF Coordinators  
Michael Deane  
Kiri Anderer

## Attachment A: Infrastructure Investment and Jobs Act (IIJA) Signage Required Term and Condition

**This Term & Condition applies to construction projects funded in whole or in part by the Infrastructure Investment and Jobs Act (IIJA) for the following programs: Clean Water State Revolving Fund (CWSRF), Drinking Water State Revolving Fund (DWSRF), Brownfields, Superfund, Emerging Contaminants, Great Lakes Restoration Initiative (GLRI), and Solid Waste Infrastructure for Recycling (SWIFR).**

### 1. Signage Requirements

a. Building A Better America Emblem: The recipient will ensure that a sign is placed at construction sites supported under this award displaying the official Building A Better America emblem and must identify the project as a “project funded by President Biden’s Bipartisan Infrastructure Law.” Construction is defined at 40 CFR 33.103 as “erection, alteration, or repair (including dredging, excavating, and painting) of buildings, structures, or other improvements to real property, and activities in response to a release or a threat of a release of a hazardous substance into the environment, or activities to prevent the introduction of a hazardous substance into a water supply.” The sign must be placed at construction sites in an easily visible location that can be directly linked to the work taking place and must be maintained in good condition throughout the construction period.

The recipient will ensure compliance with the guidelines and design specifications for using the official Building A Better America emblem and corresponding logomark available at:

<https://www.whitehouse.gov/wp-content/uploads/2022/08/Building-A-Better-America-Brand-Guide.pdf>

b. EPA Logo: The recipient will ensure that signage displays the EPA logo along with the official Building A Better America emblem. The EPA logo must not be displayed in a manner that implies that EPA itself is conducting the project. Instead, the EPA logo must be accompanied with a statement indicating that the recipient received financial assistance from EPA for the project. The recipient will ensure compliance with the sign specifications provided by the EPA Office of Public Affairs (OPA) available at: <https://www.epa.gov/grants/epa-logo-seal-specifications-signage-produced-epa-assistance-agreement-recipients>. As provided in the sign specifications from OPA, the EPA logo is the preferred identifier for assistance agreement projects and use of the EPA seal requires prior approval from the EPA. To obtain the appropriate EPA logo or seal graphic file, the recipient should send a request directly to OPA and include the EPA Project Officer in the communication. Instructions for contacting OPA is available on the [Using the EPA Seal and Logo page](#).

c. Procuring Signs: Consistent with section 6002 of RCRA, 42 U.S.C. 6962, and 2 CFR 200.323, recipients are encouraged to use recycled or recovered materials when procuring signs. Signage costs are considered an allowable cost under this assistance agreement provided that the costs associated with signage are reasonable. Additionally, to increase public awareness of projects serving communities where English is not the predominant language, recipients are encouraged to translate the language on signs (excluding the official Building A Better America emblem or EPA logo or seal) into the appropriate non-English language(s). The costs of such translation are allowable, provided the costs are reasonable.

### 2. Public or Media Events

EPA encourages the recipient to notify the EPA Project Officer listed in this award document of public or media events publicizing the accomplishment of significant events related to construction projects as a result of this agreement and provide the opportunity for attendance and participation by federal representatives with at least ten (10) working days' notice.



UNITED STATES ENVIRONMENTAL PROTECTION AGENCY  
WASHINGTON, D.C. 20460

MAR 20 2014

OFFICE OF WATER

MEMORANDUM

SUBJECT: Implementation of American Iron and Steel provisions of P.L. 113-76,  
Consolidated Appropriations Act, 2014

FROM: f ( Andrew D. Sawyers, Director  
v) Office of Wastewater Management (4201M)  
Peter C. Grevatt, Director  
Office of Ground Water and Drinking Water (4601M)

C.  
Handwritten signature of Peter C. Grevatt in black ink.

TO: Water Management Division Directors  
Regions I - X

P.L. 113-76, Consolidated Appropriations Act, 2014 (Act), includes an "American Iron and Steel (AIS)" requirement in section 436 that requires Clean Water State Revolving Loan Fund (CWSRF) and Drinking Water State Revolving Loan Fund (DWSRF) assistance recipients to use iron and steel products that are produced in the United States for projects for the construction, alteration, maintenance, or repair of a public water system or treatment works if the project is funded through an assistance agreement executed beginning January 17, 2014 (enactment of the Act), through the end of Federal Fiscal Year 2014.

Section 436 also sets forth certain circumstances under which EPA may waive the AIS requirement. Furthermore, the Act specifically exempts projects where engineering plans and specifications were approved by a State agency prior to January 17, 2014.

The approach described below explains how EPA will implement the AIS requirement. The first section is in the form of questions and answers that address the types of projects that must comply with the AIS requirement, the types of products covered by the AIS requirement, and compliance. The second section is a step-by-step process for requesting waivers and the circumstances under which waivers may be granted.

## Implementation

The Act states:

Sec. 436. (a)(1) None of the funds made available by a State water pollution control revolving fund as authorized by title VI of the Federal Water Pollution Control Act (33 U.S.C. 1381 et seq.) or made available by a drinking water treatment revolving loan fund as authorized by section 1452 of the Safe Drinking Water Act (42 U.S.C. 300j-12) shall be used for a project for the construction, alteration, maintenance, or repair of a public water system or treatment works unless all of the iron and steel products used in the project are produced in the United States.

(2) In this section, the term “iron and steel products” means the following products made primarily of iron or steel: lined or unlined pipes and fittings, manhole covers and other municipal castings, hydrants, tanks, flanges, pipe clamps and restraints, valves, structural steel, reinforced precast concrete, and construction materials.

(b) Subsection (a) shall not apply in any case or category of cases in which the Administrator of the Environmental Protection Agency (in this section referred to as the “Administrator”) finds that—

(1) applying subsection (a) would be inconsistent with the public interest;

(2) iron and steel products are not produced in the United States in sufficient and reasonably available quantities and of a satisfactory quality; or

(3) inclusion of iron and steel products produced in the United States will increase the cost of the overall project by more than 25 percent.

(c) If the Administrator receives a request for a waiver under this section, the Administrator shall make available to the public on an informal basis a copy of the request and information available to the Administrator concerning the request, and shall allow for informal public input on the request for at least 15 days prior to making a finding based on the request. The Administrator shall make the request and accompanying information available by electronic means, including on the official public Internet Web site of the Environmental Protection Agency.

(d) This section shall be applied in a manner consistent with United States obligations under international agreements.

(e) The Administrator may retain up to 0.25 percent of the funds appropriated in this Act for the Clean and Drinking Water State Revolving Funds for carrying out

the provisions described in subsection (a)(1) for management and oversight of the requirements of this section.

(f) This section does not apply with respect to a project if a State agency approves the engineering plans and specifications for the project, in that agency's capacity to approve such plans and specifications prior to a project requesting bids, prior to the date of the enactment of this Act.

The following questions and answers provide guidance for implementing and complying with the AIS requirements:

### **Project Coverage**

#### **1) What classes of projects are covered by the AIS requirement?**

All treatment works projects funded by a CWSRF assistance agreement, and all public water system projects funded by a DWSRF assistance agreement, from the date of enactment through the end of Federal Fiscal Year 2014, are covered. The AIS requirements apply to the entirety of the project, no matter when construction begins or ends. Additionally, the AIS requirements apply to all parts of the project, no matter the source of funding.

#### **2) Does the AIS requirement apply to nonpoint source projects or national estuary projects?**

No. Congress did not include an AIS requirement for nonpoint source and national estuary projects unless the project can also be classified as a 'treatment works' as defined by section 212 of the Clean Water Act.

#### **3) Are any projects for the construction, alteration, maintenance, or repair of a public water system or treatment works excluded from the AIS requirement?**

Any project, whether a treatment works project or a public water system project, for which engineering plans and specifications were approved by the responsible state agency prior to January 17, 2014, is excluded from the AIS requirements.

#### **4) What if the project does not have approved engineering plans and specifications but has signed an assistance agreement with a CWSRF or DWSRF program prior to January 17, 2014?**

The AIS requirements do not apply to any project for which an assistance agreement was signed prior to January 17, 2014.

**5) What if the project does not have approved engineering plans and specifications, but bids were advertised prior to January 17, 2014 and an assistance agreement was signed after January 17, 2014?**

If the project does not require approved engineering plans and specifications, the bid advertisement date will count in lieu of the approval date for purposes of the exemption in section 436(f).

**6) What if the assistance agreement that was signed prior to January 17, 2014, only funded a part of the overall project, where the remainder of the project will be funded later with another SRF loan?**

If the original assistance agreement funded any construction of the project, the date of the original assistance agreement counts for purposes of the exemption. If the original assistance agreement was only for planning and design, the date of that assistance agreement will count for purposes of the exemption only if there is a written commitment or expectation on the part of the assistance recipient to fund the remainder of the project with SRF funds.

**7) What if the assistance agreement that was signed prior to January 17, 2014, funded the first phase of a multi-phase project, where the remaining phases will be funded by SRF assistance in the future?**

In such a case, the phases of the project will be considered a single project if all construction necessary to complete the building or work, regardless of the number of contracts or assistance agreements involved, are closely related in purpose, time and place. However, there are many situations in which major construction activities are clearly undertaken in phases that are distinct in purpose, time, or place. In the case of distinct phases, projects with engineering plans and specifications approval or assistance agreements signed prior to January 17, 2014 would be excluded from AIS requirements while those approved/signed on January 17, 2014, or later would be covered by the AIS requirements.

**8) What if a project has split funding from a non-SRF source?**

Many States intend to fund projects with “split” funding, from the SRF program and from State or other programs. Based on the Act language in section 436, which requires that American iron and steel products be used in any project for the construction, alteration, maintenance, or repair of a public water system or treatment works receiving SRF funding between and including January 17, 2014 and September 30, 2014, any project that is funded in whole or in part with such funds must comply with the AIS requirement. A “project” consists of all construction necessary to complete the building or work regardless of the number of contracts or assistance agreements involved so long as all contracts and assistance agreements awarded are closely related in purpose, time and place. This precludes the intentional splitting of SRF projects into separate and smaller contracts or assistance agreements to avoid AIS coverage on some portion of a larger project, particularly where the activities are integrally and proximately related to the whole. However, there are many situations in which major construction activities are clearly undertaken in separate phases that are distinct in purpose, time, or place, in which



case, separate contracts or assistance agreement for SRF and State or other funding would carry separate requirements.

**9) What about refinancing?**

If a project began construction, financed from a non-SRF source, prior to January 17, 2014, but is refinanced through an SRF assistance agreement executed on or after January 17, 2014 and prior to October 1, 2014, AIS requirements will apply to all construction that occurs on or after January 17, 2014, through completion of construction, unless, as is likely, engineering plans and specifications were approved by a responsible state agency prior to January 17, 2014. There is no retroactive application of the AIS requirements where a refinancing occurs for a project that has completed construction prior to January 17, 2014.

**10) Do the AIS requirements apply to any other EPA programs, besides the SRF program, such as the Tribal Set-aside grants or grants to the Territories and DC?**

No, the AIS requirement only applies to funds made available by a State water pollution control revolving fund as authorized by title VI of the Federal Water Pollution Control Act (33 U.S.C. 1381 et seq.) or made available by a drinking water treatment revolving loan fund as authorized by section 1452 of the Safe Drinking Water Act (42 U.S.C. 300j-12)

**Covered Iron and Steel Products**

**11) What is an iron or steel product?**

For purposes of the CWSRF and DWSRF projects that must comply with the AIS requirement, an iron or steel product is one of the following made primarily of iron or steel that is permanently incorporated into the public water system or treatment works:

- Lined or unlined pipes or fittings;
- Manhole Covers;
- Municipal Castings (defined in more detail below);
- Hydrants;
- Tanks;
- Flanges;
- Pipe clamps and restraints;
- Valves;
- Structural steel (defined in more detail below);
- Reinforced precast concrete; and
- Construction materials (defined in more detail below).

**12) What does the term ‘primarily iron or steel’ mean?**

‘Primarily iron or steel’ places constraints on the list of products above. For one of the listed products to be considered subject to the AIS requirements, it must be made of greater than 50% iron or steel, measured by cost. The cost should be based on the material costs.

**13) Can you provide an example of how to perform a cost determination?**

For example, the iron portion of a fire hydrant would likely be the bonnet, body and shoe, and the cost then would include the pouring and casting to create those components. The other material costs would include non-iron and steel internal workings of the fire hydrant (i.e., stem, coupling, valve, seals, etc). However, the assembly of the internal workings into the hydrant body would not be included in this cost calculation. If one of the listed products is not made primarily of iron or steel, United States (US) provenance is not required. An exception to this definition is reinforced precast concrete, which is addressed in a later question.

**14) If a product is composed of more than 50% iron or steel, but is not listed in the above list of items, must the item be produced in the US? Alternatively, must the iron or steel in such a product be produced in the US?**

The answer to both question is no. Only items on the above list must be produced in the US. Additionally, the iron or steel in a non-listed item can be sourced from outside the US.

**15) What is the definition of steel?**

Steel means an alloy that includes at least 50 percent iron, between .02 and 2 percent carbon, and may include other elements. Metallic elements such as chromium, nickel, molybdenum, manganese, and silicon may be added during the melting of steel for the purpose of enhancing properties such as corrosion resistance, hardness, or strength. The definition of steel covers carbon steel, alloy steel, stainless steel, tool steel and other specialty steels.

**16) What does ‘produced in the United States’ mean?**

Production in the United States of the iron or steel products used in the project requires that all manufacturing processes, including application of coatings, must take place in the United States, with the exception of metallurgical processes involving refinement of steel additives. All manufacturing processes includes processes such as melting, refining, forming, rolling, drawing, finishing, fabricating and coating. Further, if a domestic iron and steel product is taken out of the US for any part of the manufacturing process, it becomes foreign source material. However, raw materials such as iron ore, limestone and iron and steel scrap are not covered by the AIS requirement, and the material(s), if any, being applied as a coating are similarly not covered. Non-iron or steel components of an iron and steel product may come from non-US sources. For example, for products such as valves and hydrants, the individual non-iron and steel components

do not have to be of domestic origin.

**17) Are the raw materials used in the production of iron or steel required to come from US sources?**

No. Raw materials, such as iron ore, limestone, scrap iron, and scrap steel, can come from non-US sources.

**18) If an above listed item is primarily made of iron or steel, but is only at the construction site temporarily, must such an item be produced in the US?**

No. Only the above listed products made primarily of iron or steel, permanently incorporated into the project must be produced in the US. For example trench boxes, scaffolding or equipment, which are removed from the project site upon completion of the project, are not required to be made of U.S. Iron or Steel.

**19) What is the definition of ‘municipal castings’?**

Municipal castings are cast iron or steel infrastructure products that are melted and cast. They typically provide access, protection, or housing for components incorporated into utility owned drinking water, storm water, wastewater, and surface infrastructure. They are typically made of grey or ductile iron, or steel. Examples of municipal castings are:

- Access Hatches;
- Ballast Screen;
- Benches (Iron or Steel);
- Bollards;
- Cast Bases;
- Cast Iron Hinged Hatches, Square and Rectangular;
- Cast Iron Riser Rings;
- Catch Basin Inlet;
- Cleanout/Monument Boxes;
- Construction Covers and Frames;
- Curb and Corner Guards;
- Curb Openings;
- Detectable Warning Plates;
- Downspout Shoes (Boot, Inlet);
- Drainage Grates, Frames and Curb Inlets;
- Inlets;
- Junction Boxes;
- Lampposts;
- Manhole Covers, Rings and Frames, Risers;

Meter Boxes;  
Service Boxes;  
Steel Hinged Hatches, Square and Rectangular;  
Steel Riser Rings;  
Trash receptacles;  
Tree Grates;  
Tree Guards;  
Trench Grates; and  
Valve Boxes, Covers and Risers.

## **20) What is ‘structural steel’?**

Structural steel is rolled flanged shapes, having at least one dimension of their cross-section three inches or greater, which are used in the construction of bridges, buildings, ships, railroad rolling stock, and for numerous other constructional purposes. Such shapes are designated as wide-flange shapes, standard I-beams, channels, angles, tees and zees. Other shapes include H-piles, sheet piling, tie plates, cross ties, and those for other special purposes.

## **21) What is a ‘construction material’ for purposes of the AIS requirement?**

Construction materials are those articles, materials, or supplies made primarily of iron and steel, that are permanently incorporated into the project, not including mechanical and/or electrical components, equipment and systems. Some of these products may overlap with what is also considered “structural steel”. This includes, but is not limited to, the following products: wire rod, bar, angles, concrete reinforcing bar, wire, wire cloth, wire rope and cables, tubing, framing, joists, trusses, fasteners (i.e., nuts and bolts), welding rods, decking, grating, railings, stairs, access ramps, fire escapes, ladders, wall panels, dome structures, roofing, ductwork, surface drains, cable hanging systems, manhole steps, fencing and fence tubing, guardrails, doors, and stationary screens.

## **22) What is not considered a ‘construction material’ for purposes of the AIS requirement?**

Mechanical and electrical components, equipment and systems are not considered construction materials. Mechanical equipment is typically that which has motorized parts and/or is powered by a motor. Electrical equipment is typically any machine powered by electricity and includes components that are part of the electrical distribution system.

The following examples (including their appurtenances necessary for their intended use and operation) are NOT considered construction materials: pumps, motors, gear reducers, drives (including variable frequency drives (VFDs)), electric/pneumatic/manual accessories used to operate valves (such as electric valve actuators), mixers, gates, motorized screens (such as traveling screens), blowers/aeration equipment, compressors, meters, sensors, controls and switches, supervisory control and data acquisition (SCADA), membrane bioreactor systems, membrane filtration systems, filters, clarifiers and clarifier mechanisms, rakes, grinders, disinfection systems, presses (including belt presses), conveyors, cranes, HVAC (excluding ductwork), water heaters,

heat exchangers, generators, cabinetry and housings (such as electrical boxes/enclosures), lighting fixtures, electrical conduit, emergency life systems, metal office furniture, shelving, laboratory equipment, analytical instrumentation, and dewatering equipment.

**23) If the iron or steel is produced in the US, may other steps in the manufacturing process take place outside of the US, such as assembly?**

No. Production in the US of the iron or steel used in a listed product requires that all manufacturing processes must take place in the United States, except metallurgical processes involving refinement of steel additives.

**24) What processes must occur in the US to be compliant with the AIS requirement for reinforced precast concrete?**

While reinforced precast concrete may not be at least 50% iron or steel, in this particular case, the reinforcing bar and wire must be produced in the US and meet the same standards as for any other iron or steel product. Additionally, the casting of the concrete product must take place in the US. The cement and other raw materials used in concrete production are not required to be of domestic origin.

If the reinforced concrete is cast at the construction site, the reinforcing bar and wire are considered to be a construction material and must be produced in the US.

**Compliance**

**25) How should an assistance recipient document compliance with the AIS requirement?**

In order to ensure compliance with the AIS requirement, specific AIS contract language must be included in each contract, starting with the assistance agreement, all the way down to the purchase agreements. Sample language for assistance agreements and contracts can be found in Appendix 3 and 4.

EPA recommends the use of a step certification process, similar to one used by the Federal Highway Administration. The step certification process is a method to ensure that producers adhere to the AIS requirement and assistance recipients can verify that products comply with the AIS requirement. The process also establishes accountability and better enables States to take enforcement actions against violators.

Step certification creates a paper trail which documents the location of the manufacturing process involved with the production of steel and iron materials. A step certification is a process under which each handler (supplier, fabricator, manufacturer,

processor, etc) of the iron and steel products certifies that their step in the process was domestically performed. Each time a step in the manufacturing process takes place, the manufacturer delivers its work along with a certification of its origin. A certification can be quite simple. Typically, it includes the name of the manufacturer, the location of the manufacturing facility where the product or process took place (not its headquarters), a description of the product or item being delivered, and a signature by a manufacturer's responsible party. Attached, as Appendix 5, are sample certifications. These certifications should be collected and maintained by assistance recipients.

Alternatively, the final manufacturer that delivers the iron or steel product to the worksite, vendor, or contractor, may provide a certification asserting that all manufacturing processes occurred in the US. While this type of certification may be acceptable, it may not provide the same degree of assurance. Additional documentation may be needed if the certification is lacking important information. Step certification is the best practice.

**26) How should a State ensure assistance recipients are complying with the AIS requirement?**

In order to ensure compliance with the AIS requirement, States SRF programs must include specific AIS contract language in the assistance agreement. Sample language for assistance agreements can be found in Appendix 3.

States should also, as a best practice, conduct site visits of projects during construction and review documentation demonstrating proof of compliance which the assistance recipient has gathered.

**27) What happens if a State or EPA finds a non-compliant iron and/or steel product permanently incorporated in the project?**

If a potentially non-compliant product is identified, the State should notify the assistance recipient of the apparent unauthorized use of the non-domestic component, including a proposed corrective action, and should be given the opportunity to reply. If unauthorized use is confirmed, the State can take one or more of the following actions: request a waiver where appropriate; require the removal of the non-domestic item; or withhold payment for all or part of the project. Only EPA can issue waivers to authorize the use of a non-domestic item. EPA may use remedies available to it under the Clean Water Act, the Safe Drinking Water Act, and 40 CFR part 31 grant regulations, in the event of a violation of a grant term and condition.

It is recommended that the State work collaboratively with EPA to determine the appropriate corrective action, especially in cases where the State is the one who identifies the item in noncompliance or there is a disagreement with the assistance recipient.

If fraud, waste, abuse, or any violation of the law is suspected, the Office of Inspector General (OIG) should be contacted immediately. The OIG can be reached at 1-888-546-8740 or [OIG\\_Hotline@epa.gov](mailto:OIG_Hotline@epa.gov). More information can be found at this website: <http://www.epa.gov/oig/hotline.htm>.

## **28) How do international trade agreements affect the implementation of the AIS requirements?**

The AIS provision applies in a manner consistent with United States obligations under international agreements. Typically, these obligations only apply to direct procurement by the entities that are signatories to such agreements. In general, SRF assistance recipients are not signatories to such agreements, so these agreements have no impact on this AIS provision. In the few instances where such an agreement applies to a municipality, that municipality is under the obligation to determine its applicability and requirements and document the actions taken to comply for the State.

### **Waiver Process**

The statute permits EPA to issue waivers for a case or category of cases where EPA finds (1) that applying these requirements would be inconsistent with the public interest; (2) iron and steel products are not produced in the US in sufficient and reasonably available quantities and of a satisfactory quality; or (3) inclusion of iron and steel products produced in the US will increase the cost of the overall project by more than 25 percent.

In order to implement the AIS requirements, EPA has developed an approach to allow for effective and efficient implementation of the waiver process to allow projects to proceed in a timely manner. The framework described below will allow States, on behalf of the assistance recipients, to apply for waivers of the AIS requirement directly to EPA Headquarters. Only waiver requests received from states will be considered. Pursuant to the Act, EPA has the responsibility to make findings as to the issuance of waivers to the AIS requirements.

### **Definitions**

The following terms are critical to the interpretation and implementation of the AIS requirements and apply to the process described in this memorandum:

Reasonably Available Quantity: The quantity of iron or steel products is available or will be available at the time needed and place needed, and in the proper form or specification as specified in the project plans and design.

Satisfactory Quality: The quality of iron or steel products, as specified in the project plans and designs.

Assistance Recipient: A borrower or grantee that receives funding from a State CWSRF or DWSRF program.

## **Step-By-Step Waiver Process**

### Application by Assistance Recipient

Each local entity that receives SRF water infrastructure financial assistance is required by section 436 of the Act to use American made iron and steel products in the construction of its project. However, the recipient may request a waiver. Until a waiver is granted by EPA, the AIS requirement stands, except as noted above with respect to municipalities covered by international agreements.

The waiver process begins with the SRF assistance recipient. In order to fulfill the AIS requirement, the assistance recipient must in good faith design the project (where applicable) and solicit bids for construction with American made iron and steel products. It is essential that the assistance recipient include the AIS terms in any request for proposals or solicitations for bids, and in all contracts (see Appendix 3 for sample construction contract language). The assistance recipient may receive a waiver at any point before, during, or after the bid process, if one or more of three conditions is met:

1. Applying the American Iron and Steel requirements of the Act would be inconsistent with the public interest;
2. Iron and steel products are not produced in the United States in sufficient and reasonably available quantities and of a satisfactory quality; or
3. Inclusion of iron and steel products produced in the United States will increase the cost of the overall project by more than 25 percent.

Proper and sufficient documentation must be provided by the assistance recipient. A checklist detailing the types of information required for a waiver to be processed is attached as Appendix 1.

Additionally, it is strongly encouraged that assistance recipients hold pre-bid conferences with potential bidders. A pre-bid conference can help to identify iron and steel products needed to complete the project as described in the plans and specifications that may not be available from domestic sources. It may also identify the need to seek a waiver prior to bid, and can help inform the recipient on compliance options.

In order to apply for a project waiver, the assistance recipient should email the request in the form of a Word document (.doc) to the State SRF program. It is strongly recommended that the State designate a single person for all AIS communications. The State SRF designee will review the application for the waiver and determine whether the necessary information has been included. Once the waiver application is complete, the State designee will forward the application to the EPA for review.

### Evaluation by EPA

After receiving an application for waiver of the AIS requirements, EPA Headquarters will publish the request on its website for 15 days and receive informal comment. EPA Headquarters will then use the checklist in Appendix 2 to determine whether the application properly and adequately documents and justifies the statutory basis cited for the waiver – that it is quantitatively and qualitatively sufficient – and to



determine whether or not to grant the waiver.

In the event that EPA finds that adequate documentation and justification has been submitted, the Administrator may grant a waiver to the assistance recipient. EPA will notify the State designee that a waiver request has been approved or denied as soon as such a decision has been made. Granting such a waiver is a three-step process:

1. Posting – After receiving an application for a waiver, EPA is required to publish the application and all material submitted with the application on EPA’s website for 15 days. During that period, the public will have the opportunity to review the request and provide informal comment to EPA. The website can be found at: [http://water.epa.gov/grants\\_funding/aisrequirement.cfm](http://water.epa.gov/grants_funding/aisrequirement.cfm)
2. Evaluation – After receiving an application for waiver of the AIS requirements, EPA Headquarters will use the checklist in Appendix 2 to determine whether the application properly and adequately documents and justifies the statutory basis cited for the waiver – that it is quantitatively and qualitatively sufficient – and to determine whether or not to grant the waiver.
3. Signature of waiver approval by the Administrator or another agency official with delegated authority – As soon as the waiver is signed and dated, EPA will notify the State SRF program, and post the signed waiver on our website. The assistance recipient should keep a copy of the signed waiver in its project files.

### Public Interest Waivers

EPA has the authority to issue public interest waivers. Evaluation of a public interest waiver request may be more complicated than that of other waiver requests so they may take more time than other waiver requests for a decision to be made. An example of a public interest waiver that might be issued could be for a community that has standardized on a particular type or manufacturer of a valve because of its performance to meet their specifications. Switching to an alternative valve may require staff to be trained on the new equipment and additional spare parts would need to be purchased and stocked, existing valves may need to be unnecessarily replaced, and portions of the system may need to be redesigned. Therefore, requiring the community to install an alternative valve would be inconsistent with public interest.

EPA also has the authority to issue a public interest waiver that covers categories of products that might apply to all projects.

EPA reserves the right to issue national waivers that may apply to particular classes of assistance recipients, particular classes of projects, or particular categories of iron or steel products. EPA may develop national or (US geographic) regional categorical waivers through the identification of similar circumstances in the detailed justifications presented to EPA in a waiver request or requests. EPA may issue a national waiver based on policy decisions regarding the public's interest or a determination that a particular item is not produced domestically in reasonably available quantities or of a sufficient quality. In such cases, EPA may determine it is necessary to issue a national waiver.

If you have any questions concerning the contents of this memorandum, you may contact us, or have your staff contact Jordan Dorfman, Attorney-Advisor, State Revolving Fund Branch, Municipal Support Division, at [dorfman.jordan@epa.gov](mailto:dorfman.jordan@epa.gov) or (202) 564-0614 or Kiri Anderer, Environmental Engineer, Infrastructure Branch, Drinking Water Protection Division, at [anderer.kirsten@epa.gov](mailto:anderer.kirsten@epa.gov) or (202) 564-3134.

Attachments

## Appendix 1: Information Checklist for Waiver Request

The purpose of this checklist is to help ensure that all appropriate and necessary information is submitted to EPA. EPA recommends that States review this checklist carefully and provide all appropriate information to EPA. This checklist is for informational purposes only and does not need to be included as part of a waiver application.

Items	✓	Notes
<p><b>General</b></p> <ul style="list-style-type: none"> <li>• Waiver request includes the following information:               <ul style="list-style-type: none"> <li>— Description of the foreign and domestic construction materials</li> <li>— Unit of measure</li> <li>— Quantity</li> <li>— Price</li> <li>— Time of delivery or availability</li> <li>— Location of the construction project</li> <li>— Name and address of the proposed supplier</li> <li>— A detailed justification for the use of foreign construction materials</li> </ul> </li> <li>• Waiver request was submitted according to the instructions in the memorandum</li> <li>• Assistance recipient made a good faith effort to solicit bids for domestic iron and steel products, as demonstrated by language in requests for proposals, contracts, and communications with the prime contractor</li> </ul>	✓	
<p><b>Cost Waiver Requests</b></p> <ul style="list-style-type: none"> <li>• Waiver request includes the following information:               <ul style="list-style-type: none"> <li>— Comparison of overall cost of project with domestic iron and steel products to overall cost of project with foreign iron and steel products</li> <li>— Relevant excerpts from the bid documents used by the contractors to complete the comparison</li> <li>— Supporting documentation indicating that the contractor made a reasonable survey of the market, such as a description of the process for identifying suppliers and a list of contacted suppliers</li> </ul> </li> </ul>		
<p><b>Availability Waiver Requests</b></p> <ul style="list-style-type: none"> <li>• Waiver request includes the following supporting documentation necessary to demonstrate the availability, quantity, and/or quality of the materials for which the waiver is requested:               <ul style="list-style-type: none"> <li>— Supplier information or pricing information from a reasonable number of domestic suppliers indicating availability/delivery date for construction materials</li> <li>— Documentation of the assistance recipient's efforts to find available domestic sources, such as a description of the process for identifying suppliers and a list of contacted suppliers.</li> <li>— Project schedule</li> <li>— Relevant excerpts from project plans, specifications, and permits indicating the required quantity and quality of construction materials</li> </ul> </li> <li>• Waiver request includes a statement from the prime contractor and/or supplier confirming the non-availability of the domestic construction materials for which the waiver is sought</li> <li>• Has the State received other waiver requests for the materials described in this waiver request, for comparable projects?</li> </ul>		

## Appendix 2: HQ Review Checklist for Waiver Request

Instructions: To be completed by EPA. Review all waiver requests using the questions in the checklist, and mark the appropriate box as Yes, No or N/A. Marks that fall inside the shaded boxes may be grounds for denying the waiver. If none of your review markings fall into a shaded box, the waiver is eligible for approval if it indicates that one or more of the following conditions applies to the domestic product for which the waiver is sought:

1. The iron and/or steel products are not produced in the United States in sufficient and reasonably available quantities and of a satisfactory quality.
2. The inclusion of iron and/or steel products produced in the United States will increase the cost of the overall project by more than 25 percent.

Review Items	Yes	No	N/A	Comments
<p><b>Cost Waiver Requests</b></p> <ul style="list-style-type: none"> <li>• Does the waiver request include the following information?               <ul style="list-style-type: none"> <li>— Comparison of overall cost of project with domestic iron and steel products to overall cost of project with foreign iron and steel products</li> <li>— Relevant excerpts from the bid documents used by the contractors to complete the comparison</li> <li>— A sufficient number of bid documents or pricing information from domestic sources to constitute a reasonable survey of the market</li> </ul> </li> <li>• Does the Total Domestic Project exceed the Total Foreign Project Cost by more than 25%?</li> </ul>				
<p><b>Availability Waiver Requests</b></p> <ul style="list-style-type: none"> <li>• Does the waiver request include supporting documentation sufficient to show the availability, quantity, and/or quality of the iron and/or steel product for which the waiver is requested?               <ul style="list-style-type: none"> <li>— Supplier information or other documentation indicating availability/delivery date for materials</li> <li>— Project schedule</li> <li>— Relevant excerpts from project plans, specifications, and permits indicating the required quantity and quality of materials</li> </ul> </li> <li>• Does supporting documentation provide sufficient evidence that the contractors made a reasonable effort to locate domestic suppliers of materials, such as a description of the process for identifying suppliers and a list of contacted suppliers?</li> <li>• Based on the materials delivery/availability date indicated in the supporting documentation, will the materials be unavailable when they are needed according to the project schedule? (By item, list schedule date and domestic delivery quote date or other relevant information)</li> <li>• Is EPA aware of any other evidence indicating the non-availability of the materials for which the waiver is requested?               <p>Examples include:</p> <ul style="list-style-type: none"> <li>— Multiple waiver requests for the materials described in this waiver request, for comparable projects in the same State</li> <li>— Multiple waiver requests for the materials described in this waiver request, for comparable projects in other States</li> <li>— Correspondence with construction trade associations indicating the non-availability of the materials</li> </ul> </li> <li>• Are the available domestic materials indicated in the bid documents of inadequate quality compared those required by the project plans, specifications, and/or permits?</li> </ul>				

## Appendix 5: Sample Certifications

The following information is provided as a sample letter of **step** certification for AIS compliance. Documentation must be provided on company letterhead.

Date

Company Name

Company Address

City, State Zip

Subject: American Iron and Steel Step Certification for Project (XXXXXXXXXX)

I, (company representative), certify that the (melting, bending, coating, galvanizing, cutting, etc.) process for (manufacturing or fabricating) the following products and/or materials shipped or provided for the subject project is in full compliance with the American Iron and Steel requirement as mandated in EPA's State Revolving Fund Programs.

Item, Products and/or Materials:

1. XXXX
2. XXXX
3. XXXX

Such process took place at the following location:

\_\_\_\_\_

If any of the above compliance statements change while providing material to this project we will immediately notify the prime contractor and the engineer.

Signed by company representative

The following information is provided as a sample letter of certification for AIS compliance. Documentation must be provided on company letterhead.

Date

Company Name

Company Address

City, State Zip

Subject: American Iron and Steel Certification for Project (XXXXXXXXXXXX)

I, (company representative), certify that the following products and/or materials shipped/provided to the subject project are in full compliance with the American Iron and Steel requirement as mandated in EPA's State Revolving Fund Programs.

Item, Products and/or Materials:

1. XXXX
2. XXXX
3. XXXX

Such process took place at the following location:

\_\_\_\_\_

If any of the above compliance statements change while providing material to this project we will immediately notify the prime contractor and the engineer.

Signed by company representative

**American Iron & Steel (AIS) Requirement of the Consolidated Appropriations Act of 2014  
(Public Law 113-76)**

**Q&A Part 2**

**PRODUCT QUESTIONS**

**1. Q: Do all fasteners qualify for de minimis exemption?**

**A: No.** There is no broad exemption for fasteners from the American Iron and Steel (AIS) requirements. Significant fasteners used in SRF projects are not subject to the de minimis waiver for projects and must comply with the AIS requirements. Significant fasteners include fasteners produced to industry standards (e.g., ASTM standards) and/or project specifications, special ordered or those of high value. When bulk purchase of unknown-origin fasteners that are of incidental use and small value are used on a project, they may fall under the national de minimis waiver for projects. The list of potential items could be varied, such as big-box/hardware-store-variety screws, nails, and staples. The key characteristics of the items that may qualify for the de minimis waiver would be items that are incidental to the project purpose (such as drywall screws) and not significant in value or purpose (such as common nails or brads).

EPA also clarifies that minor components of two listed products – valves and hydrants -- may not need to meet the AIS requirements if the minor components compromise a very small quantity of minor, low-cost fasteners that are of unknown origin.

**2. Q: Does PCCP pipe have to be domestically produced?**

**A: Yes.** Pre-stressed concrete cylinder pipe (PCCP) or other similar concrete cylinder pipes would be comparable to pre-cast concrete which is specifically listed in the Consolidated Appropriations Act of 2014 as a product subject to the AIS requirement.

**3. Q: If the iron or steel is made from recycled metals will the vendor/supplier have to provide a certification document certifying that the recycled metals are domestically produced?**

**A: No.** Recycled source materials used in the production of iron and steel products do not have to come from the U.S. Iron or steel scrap, for instance, are considered raw materials that may come from anywhere. While certification is not required for the raw material, EPA does recommend that additional final processing of iron and steel be certified to have occurred in the U.S.

**4. Q: Do tanks used for filtration systems, if delivered to the construction site separately and then filled with filtration media onsite, have to be domestically produced?**

**A: No.** Tanks that are specifically designed to be filters, or as parts of a filtration system, do not have to be domestically produced because these parts are no longer simply tanks, even if the filter media has not been installed and will be installed at the project site, as is customary to do for shipping purposes. These parts have only one purpose which is to be housing for filters and cannot be used in another fashion.

**5. Q: Can a recipient use non-domestic flanged pipe?**

**A: No.** While the Consolidated Appropriations Act of 2014 does not specifically mention flanged pipe, since it does mention both pipe and flanges, both products would need to be domestically produced. Therefore, flanged pipe would also need to be domestically produced.

**6. Q: Can a recipient use non-domestic couplings, expansion joints, and other similar pipe connectors?**

**A: No.** These products would be considered specialty fittings, due to their additional functionality, but still categorized under the larger “fitting” categorization. Fittings are defined as a material that joins pipes together or connects to a pipe (AWWA, The Drinking Water Dictionary, 2000). Therefore, these products must comply with the AIS requirements and be produced domestically.

**7. Q: Can a recipient use non-domestic service saddles and tapping sleeves?**

**A: No.** These products are necessary for pipe repair, to tap a water main, or to install a service or house connection. Therefore, they are included under the larger “pipe restraint” category which is a specifically identified product subject to the domestic preference in the Consolidated Appropriations Act of 2014.

**8. Q: The AIS guidance does not appear to cover reused items (i.e., existing pipe fittings, used storage tanks, reusing existing valves). How should reused items be addressed?**

**A:** The AIS guidance does not address reuse of items. Reuse of items that would otherwise be covered by AIS is acceptable provided that the item(s) was originally purchased prior to January 17, 2014, the reused item(s) is not substantially altered from original form/function, and any restoration work that may be required does not include the replacement or addition of foreign iron or steel replacement parts. EPA recommends keeping a log of these reused items by including them on the assistance recipient’s de minimis list, and stating therein that these items are reused products. The donation of new items (such as a manufacturer waiving cost for certain delivered items because of concerns regarding the origin of a new product) is not, however, considered reuse.

**9. Q: What does “time needed” mean in the AIS guidance, in reference to the definition of “Reasonably Available Quantity”?**



**A:** For considering whether a product would meet reasonably available quantity, “time needed” is based on the construction schedule. If the item is delayed and there is substantial impact on the overall construction schedule, this would not be according to the “time needed.”

**10. Q: If a product is not specifically included on the list of AIS covered products, must it comply with AIS?**

**A: Possibly.** The AIS requirements include a list of specifically covered products, one of which is construction materials, a broad category of potential products. For construction materials, EPA’s AIS guidance includes a set of example items that it considers construction materials composed primarily of iron and steel and covered by the Act. This example list in the guidance is not an all-inclusive list of potential construction materials. However, the guidance also includes a list of items that EPA specifically does not consider construction materials, generally those of electrical or complex-mechanical nature. If a product is similar to the ones in the non-construction material list (and it is also not specifically listed by the Act), it is not a construction material. For all other items specifically included in the Act, coverage is generally self-evident.

**11. Q: If a listed iron and steel product is used as a part for an assembled product that is non-domestic, do the AIS requirements apply?**

**A:** AIS requirements only apply to the final product as delivered to the work site and incorporated into the project. Other assemblies, such as a pumping assembly or a reverse osmosis package plant, are distinct products not listed and do not need to be made in the U.S. or composed of all U.S. parts. Therefore, for the case of a non-covered product used in a larger non-domestic assembly, the components, even if specifically listed in the Consolidated Appropriations Act, do not have to be domestically produced.

**12. Q: Is cast iron excluded from the AIS requirements?**

**A: No.** Cast iron products that fall under the definition of iron and steel products must comply with the AIS requirements.

**13. Q: The guidance states that “construction materials” do not include mechanical equipment, but then identifies ductwork as a construction material. Please clarify.**

**A:** Ductwork is not mechanical equipment, therefore it is considered a “construction material” and must comply with the AIS requirements.

**14. Q: Do “meters” mentioned in EPA’s guidance as non-construction materials include both flow meters and water meters?**

**A: Yes.** “Meters” includes any type of meter, including: flow meters, wholesale meters, and water meters/service connections.

**15. Q: Must coiled steel be domestic?**

**A: Yes.** Coiled steel is an intermediate product used in the production of steel pipe and must come from a U.S. source or subject to a waiver in order to comply with the AIS requirements.

**16. Q: Are pig iron, direct reduced iron (DRI), and ingot considered raw materials?**

**A: No.** These are considered intermediate products used in the production of iron or steel and must come from a U.S. source or subject to a waiver in order to comply with the AIS requirements.

**17. Q: Can assistance recipients rely on a marking that reads, “Made in the USA,” as evidence that all processes took place in the U.S.?**

**A: No.** This designation is not consistent with our requirements that all manufacturing processes of iron and steel products must take place in the U.S.

**18. Q: When determining what constitutes a product made “primarily” of iron or steel, who makes this determination?**

**A:** The manufacturer will show if its product qualifies as primarily made of iron or steel. The recipient should expect the manufacturer to provide documentation/ certification that its product is AIS compliant.

**19. Q: Do aerators need to be produced domestically in order to comply with AIS?**

**A: No.** Aerators, similar to pumps, are mechanical equipment that do not need to meet the AIS requirements. “Blowers/aeration equipment, compressors” are listed in EPA’s guidance as non-construction materials.

**20. Q: Are Sluice and Slide Gates considered valves?**

**A: No.** Valves are products that are generally encased / enclosed with a body, bonnet, and stem. Examples include enclosed butterfly, ball, globe, piston, check, wedge, and gate valves. Furthermore, “gates” (meaning sluice, slide or weir gates) are listed in EPA’s guidance as non-construction materials.

**AIS PROCESS QUESTIONS**

**21. Q: Will notices of waiver applications be published in the federal register?**

**A: No.** Applications for waivers will be published on EPA’s website ([http://water.epa.gov/grants\\_funding/aisrequirement.cfm](http://water.epa.gov/grants_funding/aisrequirement.cfm)). EPA will provide 15 days for open public comment, as noted on the website.

**22. Q: Will states be collecting the step certification paper trail, as presented in the AIS guidance?**

**A. No.** Assistance recipients must maintain documentation of compliance with AIS. EPA recommends use of the step certification process. This process is a best practice and traces all manufacturing of iron and steel products to the U.S. If the process is used, the state does not have to collect the documentation. The documents must be kept by the assistance recipient and reviewed by the state during project reviews.

**23. Q: Why is it considered a best practice for states to conduct site visits, when it is the assistance recipient's responsibility to meet the AIS requirements?**

**A: It is both the assistance recipient's and the state's responsibility to ensure compliance with the AIS requirements.** The state is the recipient of a federal grant and must comply with all grant conditions, including a condition requiring that the AIS requirements be adhered to. Therefore, it is recommended that states conduct site visits of projects during construction and review documentation demonstrating the assistance recipient's proof of compliance.

**24. Q: Please further define the state's role in the waiver process.**

**A:** The state's role in the waiver process is to review any waiver requests submitted to the state in order to ensure that all necessary information has been provided by the assistance recipient prior to forwarding the request to EPA. If a state finds the request lacking, the state should work with the assistance recipient to help obtain complete information.

**25. Q: How much time does EPA have to evaluate the waiver during the evaluation step?**

**A:** At a minimum, EPA is required to provide 15 days for open public comment. There is no specific deadline or time limit for EPA to review waiver requests. Each waiver request will come with its own specific details and circumstances and may require a different amount of time for review and analysis. For example, public interest waivers in general may take longer to review than availability waivers which are typically more straightforward. However, EPA understands that construction may be delayed while waiting for a waiver and will make every effort to review and issue decisions on waiver requests in a timely manner.

## **PROJECT QUESTIONS**

**26. Q: What if a project is funded by another funding entity (i.e., United States Department of Agriculture – Rural Development) where AIS is not required and begins construction after January 17, 2014 but then applies to the SRF to refinance the project? Are they ineligible?**

**A: The project is not ineligible.** AIS requirements will apply to any construction that occurs after the assistance agreement is signed, through the end of construction. If construction is complete, there is no retroactive application of the AIS requirements.

**27. Q: If the assistance recipient can demonstrate through market research that the AIS requirement will exceed the 25 percent cost threshold, is the entire project exempt from the AIS requirement?**

**A:** If the waiver application shows that the inclusion of American iron and steel products causes the entire cost of the project to increase by more the 25 percent, a waiver may be granted for the entirety of the project.

**28. Q: Can the recipient use non-SRF funds to pay for the non-compliant item.**

**A: No.** It is not an acceptable to use non-SRF funds to pay for a non-compliant item. The Consolidated Appropriations Act of 2014 requires that all iron and steel products, no matter the source of funding, must be made in the U.S. if SRF funds are used in the project.

**29. Q: What constitutes “satisfactory quality” as defined in the AIS guidance, in reference to the availability waiver process.**

**A:** “Satisfactory quality” means the product meets the project design specifications. A waiver may be granted if a recipient determines that the project plans and design would be compromised because there are no American made products available that meet the project design specifications.

**30. Q: The guidance states that the AIS requirement applies to any project “funded in whole or in part” by an SRF. Where is this in the Act?**

**A:** The Act states that, “None of the funds made available by a ... [State SRF program] ... shall be used for a project for the construction, alteration, maintenance, or repair of a public water system or treatment works unless all of the iron and steel products used in the project are produced in the United States.” This sentence clearly states that no SRF program may use its funds for a project unless all of the iron and steel products used in the project are made in the U.S. This is true even if only \$1 of SRF funding is used in the project.

**31. Q: There is always an expectation on the part of an assistance recipient that the construction phase of a planning and/or design only loan will be funded through the SRF. If the original planning and/or design only loan was executed prior to a January 17, 2014, does this mean the entire project will be exempt from the AIS requirement?**

**A:** If the original loan includes construction, and was executed prior to January 17, 2014, then the AIS provision does not apply to the project. If the original loan was only for planning and/or design, then a written commitment or documented “expectation” is needed to show exemption from the

requirements. Appearance on a priority list in an Intended Use Plan along with written reasonable assurance from the state that the recipient will receive SRF funding for project construction could provide sufficient evidence of “expectation of funding”.

**32. Q: What if there has been a change order or redesign requiring new plans and specifications to be approved and they were approved after January 17, 2014: does the project now have to comply with AIS?**

**A: In most cases, no.** Change orders are typically small enough changes that the original plan and specification date will still hold true. For example, if a pipe alignment has to be changed for a block or two due to unforeseen conditions, but new plans and specifications had to be submitted for this section of the project, then that could be considered a minor change. However, if there has been a major redesign, perhaps the whole project had to be redesigned starting from scratch, then the new plans and specification approval date would apply.

**33. Q: What if the bids on a project with plans and specifications approved before January 17, 2014 but the loan is signed after January 17, 2014 come in low, and there is significant funding remaining in the loan agreement, so the community designs a second project with the remaining funds: does that project have to comply with the AIS requirements?**

**A:** If the second project is closely related in purpose, place and time to the first project, then the second project would be exempt from the AIS requirements. It is the assistance recipient’s responsibility (with state oversight) to show that a project is closely related, or not, in purpose, place and time.

**34. Q: What if the assistance agreement was signed after January 17, 2014, state approval of plans for the first phase of the project was in place prior to January 17, 2014, but state approval of the plans for the second phase of the project was received after January 17, 2014?**

**A:** In such a case, the AIS provision would not apply to the first phase of the project. If the second phase of the project is considered the same project as the first phase, due to its close relation in purpose, place and time, the entire project may be exempt. It is the assistance recipient’s responsibility (with state oversight) to show that phases of a project is closely related, or not, in purpose, place and time.

**35. Q: Do products purchased through procurement-only contracts have to be comply with AIS?**

**A: Yes.** For projects funded by SRF, the products procured under any form of contract must comply with AIS. A procurement-only contract generally involves the bulk purchase of common items (such as pipe, concrete, and/or pumps) of independent timing from a set of planned projects. If products which are purchased through a procurement-only contract are being installed under another contract, the procurement-only contract would probably not be considered a separate project in purpose, place and time; and therefore, would have to comply with the AIS requirements.

March 2015

## American Iron & Steel Requirement for the Clean Water and Drinking Water State Revolving Funds

### Q&A Part 3

*For CWSRF and DWSRF: On **January 17, 2014**, Public Law 113-76, the "Consolidated Appropriations Act, 2014," was enacted and included an American Iron and Steel requirement for the Clean Water and Drinking Water State Revolving Fund programs through the end of fiscal year 2014. Since then, the AIS requirement has continued for both programs, but through different statutes, with a few changes as described in the questions and answers provided below.*

*For CWSRF: On **June 10, 2014**, the Water Resources Reform and Development Act amended the Clean Water Act to include permanent requirements for the use of AIS products in CWSRF assistance agreements. Section 608 of the CWA now contains requirements for AIS that repeat those of the Consolidated Appropriations Act, 2014. All CWSRF assistance agreements must comply with Section 608 of the CWA for implementation of the permanent AIS requirement.*

*For DWSRF: On **December 16, 2014**, the President signed Public Law 113- 235, the "Consolidated and Further Continuing Appropriations Act, 2015," which provides fiscal year 2015 full-year appropriations through September 30, 2015. This law continues the requirement for the use of AIS products in DWSRF assistance agreements through September 30, 2015.*

### **CWSRF PROGRAM**

- 1. Q: The Water Resources Reform and Development Act amended the Clean Water Act to include permanent requirements for the use of AIS for CWSRF funded assistance agreements. Does the CWA include an exemption for plans and specifications approved prior to the enactment of the legislation similar to the exemption included in the Consolidated Appropriations Act (CAA) 2014?**

**A: Yes.** The WRRDA amendment to the CWA, which included AIS requirements, included a similar exemption as the CAA 2014. For any CWSRF assistance agreement signed on or after October 1, 2014, if the plans and specifications were approved prior to June 10, 2014 (the enactment of WRRDA), then the project is exempt from AIS requirements. For assistance agreements signed prior to October 1, 2014, the previous dates in the CAA 2014 apply (see March 20, 2014, AIS guidance document).

If a project does not require approved engineering plans and specifications, the bid advertisement date will count in lieu of the plans and specifications approval date for purposes of this exemption in Section 608 (f).

The following table summarizes AIS exemptions based on the plans and specifications approval date for CWSRF funded projects.

3/16/2015

<b>CWSRF AIS Project Exemption Based on Plans and Specifications Approval Date</b>		
<u>Assistance Agreement Signed:</u>	<u>Exempt from AIS if Plans and Specifications Were Approved Before:</u>	<u>Basis for Exemption:</u>
1/17/2014 through 9/30/2014	4/15/2014	<ul style="list-style-type: none"> <li>• Consolidated Appropriations Act 2014</li> <li>• National waiver signed 4/15/2014*</li> </ul>
On or after 10/1/2014	6/10/2014	<ul style="list-style-type: none"> <li>• Clean Water Act Section 608</li> </ul>

*\* To be covered by the national waiver, the plans and specifications had to be submitted to the state prior to 1/17/2014*

**2. Q: Does the AIS requirement apply to refinanced CWSRF projects?**

**A: Yes, in some cases.** If a project began construction, financed from a non-CWSRF source prior to June 10, 2014, but is refinanced through a CWSRF assistance agreement executed on or after October 1, 2014, AIS requirements will apply to all construction that occurs on or after June 10, 2014, through completion of construction, unless engineering plans and specifications were approved by the responsible state agency prior to June 10, 2014. For CWSRF projects funded on or after October 1, 2014, there is no retroactive application of the AIS requirements where a refinancing occurs for a project that has completed construction prior to June 10, 2014.

**DWSRF PROGRAM**

**3. Q: The Consolidated and Further Continuing Appropriations Act 2015 continues the AIS requirements for DWSRF funded assistance agreements. Does the Act include an exemption for plans and specifications approved prior to the enactment of the legislation, similar to the exemption included in the Consolidated Appropriations Act (CAA) 2014?**

**A: Yes.** The Consolidated and Further Continuing Appropriations Act 2015 includes a similar exemption as the CAA 2014. For any assistance agreement signed on or after December 16, 2014 (the enactment of the Act), if the plans and specifications were approved prior to December 16, 2014, then the project is exempt from the AIS requirements. For assistance agreements signed prior to December 16, 2014, the previous dates in the CAA 2014 apply (see March 20, 2014 AIS guidance document).

If a project does not require approved engineering plans and specifications, the bid advertisement date will count in lieu of the plans and specifications approval date for purposes of the exemption in Section 424(f).

3/16/2015

**4. Q: Do DWSRF assistance agreements signed during the time period between September 30, 2014, and December 16, 2014, still have to comply with the AIS requirements?**

**A: Yes.** The Continuing Appropriations Resolution 2015 was signed on September 19, 2014, which extended funding for the DWSRF with the same conditions that were made applicable by the language in the Fiscal Year 2014 appropriations, including the requirement for the use of American Iron and Steel products in projects receiving financial assistance from the DWSRF. Therefore, all assistance agreements starting October 1, 2014, through the enactment of the Consolidated and Further Continuing Appropriations Act 2015 (signed December 16, 2014), must include the AIS requirements. However, if the plans and specifications for any of these projects were approved prior to April 15, 2014 (the date the national waiver was signed), then the project is exempt from the AIS requirements.

The following table summarizes AIS exemptions based on the plans and specifications approval date for DWSRF funded projects.

<b>DWSRF AIS Project Exemption Based on Plans and Specifications Approval Date</b>		
<u>Assistance Agreement Signed:</u>	<u>Exempt from AIS if Plans and Specifications Were Approved Before:</u>	<u>Basis for Exemption:</u>
1/17/2014 through 9/30/2014	4/15/2014	<ul style="list-style-type: none"> <li>Consolidated Appropriations Act 2014</li> <li>National waiver signed 4/15/2014*</li> </ul>
10/1/2014 through 12/15/2014	4/15/2014	<ul style="list-style-type: none"> <li>Continuing Appropriations Resolution 2015 (continued CAA 2014 requirements)**</li> <li>National waiver signed 4/15/2014*</li> </ul>
12/16/2014 through 9/30/2015	12/16/2014	<ul style="list-style-type: none"> <li>Consolidated and Further Continuing Appropriations Act 2015</li> </ul>

\* To be covered by the national waiver, the plans and specifications had to be submitted to the state prior to 1/17/2014

\*\* Following the first continuing resolution, there were two additional CRs to fill the gap between 12/11/2014 and 12/16/2014

**5. Q: Does the AIS requirement apply to refinanced DWSRF projects?**

**A: Yes, in some cases.** If a project began construction, financed from a non-DWSRF source prior to December 16, 2014, but is refinanced through a DWSRF assistance agreement executed on or after December 16, 2014, AIS requirements will apply to all construction that occurs on or after December 16, 2014, through completion of construction, unless engineering plans and

3/16/2015



specifications were approved by the responsible state agency prior to December 16, 2014. For DWSRF projects funded on or after December 16, 2014, there is no retroactive application of the AIS requirements where a refinancing occurs for a project that has completed construction prior to December 16, 2014.

#### **BOTH CWSRF AND DWSRF PROGRAMS**

6. **Q: If a coating is applied to the external surface of a domestic iron or steel component, and the application takes place outside of the United States, would the product be compliant under the AIS requirements?**

**A: Yes.** The product would still be considered a compliant product under AIS requirements. Any coating processes that are applied to the external surface of iron and steel components that would otherwise be AIS compliant would not disqualify the product from meeting the AIS requirements regardless of where the coating processes occur, provided that final assembly of the product occurs in the United States.

The exemption above only applies to coatings on the *external surface* of iron and steel components. It does not apply to coatings or linings on internal surfaces of iron and steel products, such as the lining of lined pipes. All manufacturing processes for lined pipes, including the application of pipe lining, must occur in the United States for the product to be compliant with AIS requirements.



UNITED STATES ENVIRONMENTAL PROTECTION AGENCY  
WASHINGTON, D.C. 20460

OFFICE OF WAIRM

**DECISION MEMORANDUM**

**SUBJECT:** De Minimis Waiver of Section 436 of P.L. 113-76, Consolidated Appropriations Act (CAA), 2014

**FROM:** Nancy K. Stoner  
Acting Assistant Administrator

The EPA is hereby granting a nationwide waiver pursuant to the "American Iron and Steel (AIS)" requirements of P.L. 113-76, Consolidated Appropriations Act, 2014 (Act), section 436 under the authority of Section 436(b)(1) (public interest waiver) for de minimis incidental components of eligible water infrastructure projects. This action permits the use of products when they occur in de minimis incidental components of such projects funded by the Act that may otherwise be prohibited under section 436(a). Funds used for such de minimis incidental components cumulatively may comprise no more than a total of 5 percent of the total cost of the materials used in and incorporated into a project; the cost of an individual item may not exceed 1 percent of the total cost of the materials used in and incorporated into a project.

P.L. 113-76, Consolidated Appropriations Act, 2014 (Act), includes an "American Iron and Steel" (AIS) requirement in section 436 that requires Clean Water State Revolving Loan Fund (CWSRF) and Drinking Water State Revolving Loan Fund (DWSRF) assistance recipients to use specific domestic iron and steel products that are produced in the United States if the project is funded through an assistance agreement executed beginning January 17, 2014 (enactment of the Act), through the end of Fiscal Year 2014, unless the agency determines it necessary to waive this requirement based on findings set forth in Section 436(b). The Act states, "[the requirements] shall not apply in any case or category of cases in which the Administrator of the Environmental Protection Agency...finds that- (1) applying subsection (a) would be inconsistent with the public interest" 436(b)(1).

In implementing section 436 of the Act, the EPA must ensure that the section's requirements are applied consistent with congressional intent in adopting this section and in the broader context of the purposes, objectives, and other provisions applicable to projects funded under the SRF. Water infrastructure projects typically contain a relatively small number of high-cost components incorporated into the project. In bid solicitations for a project, these high-cost components are generally described in detail via project specific technical specifications. For these major components, utility owners and their contractors are generally familiar with the conditions of availability, the potential alternatives for each detailed specification, the approximate cost, and the country of manufacture of the available components.

Every water infrastructure project also involves the use of thousands of miscellaneous, generally low-cost components that are essential for, but incidental to, the construction and are incorporated into the physical structure of the project. For many of these incidental components, the country of manufacture and the availability of alternatives is not always readily or reasonably identifiable prior to procurement in the normal course of business; for other incidental components, the country of manufacture may be known but the miscellaneous character in conjunction with the low cost, individually and (in total) as typically procured in bulk, mark them as properly incidental. Examples of incidental components could include small washers, screws, fasteners (i.e., nuts and bolts), miscellaneous wire, corner bead, ancillary tube, etc. Examples of items that are clearly not incidental include significant process fittings (i.e., tees, elbows, flanges, and brackets), distribution system fittings and valves, force main valves, pipes for sewer collection and/or water distribution, treatment and storage tanks, large structural support structures, etc.

The EPA undertook multiple inquiries to identify the approximate scope of de minimis incidental components within water infrastructure projects during the implementation of the American Reinvestment and Recovery Act (ARRA) and its requirements (Buy American provisions, specifically). The inquiries and research conducted in 2009 applies suitably for the case today. In 2009, the EPA consulted informally with many major associations representing equipment manufacturers and suppliers, construction contractors, consulting engineers, and water and wastewater utilities, and performed targeted interviews with several well-established water infrastructure contractors and firms who work in a variety of project sizes, and regional and demographic settings to ask the following questions:

- What percentage of total project costs were consumables or incidental costs?
- What percentage of materials costs were consumables or incidental costs?
- Did these percentages vary by type of project (drinking water vs. wastewater treatment plant vs. pipe)?

The responses were consistent across the variety of settings and project types, and indicated that the percentage of total costs for drinking water or wastewater infrastructure projects represented by these incidental components is generally not in excess of 5 percent of the total cost of the materials used in and incorporated into a project. In drafting this waiver, the EPA has considered the de minimis proportion of project costs generally represented by each individual type of these incidental components within the many types of such components comprising those percentages, the fact that these types of incidental components are obtained by contractors in many different ways from many different sources, and the disproportionate cost and delay that would be imposed on projects if the EPA did not issue this waiver.

Assistance recipients who wish to use this waiver should in consultation with their contractors determine the items to be covered by this waiver and must retain relevant documentation (i.e., invoices) as to those items in their project files.

If you have any questions concerning the contents of this memorandum, please contact Timothy Connor, Chemical Engineer, Municipal Support Division, at [connor.timothy@epa.gov](mailto:connor.timothy@epa.gov) or (202) 566-1059 or Kirsten Anderer, Environmental Engineer, Drinking Water Protection Division, at [anderer.kirsten@epa.gov](mailto:anderer.kirsten@epa.gov) or (202) 564-3134.

**A?R t5 2014**

Issued on: \_\_\_\_\_

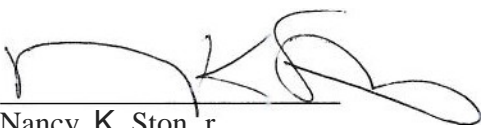
Approved by:   
\_\_\_\_\_  
Nancy K. Stoner  
Acting Assistant Administrator



## Prohibition on Telecommunications and Video Surveillance

### § 200.216 Prohibition on certain telecommunications and video surveillance services or equipment.

- (a) Recipients and subrecipients are prohibited from obligating or expending loan or grant funds to:
  - (1) Procure or obtain;
  - (2) Extend or renew a contract to procure or obtain; or
  - (3) Enter into a contract (or extend or renew a contract) to procure or obtain equipment, services, or systems that uses covered telecommunications equipment or services as a substantial or essential component of any system, or as critical technology as part of any system. As described in [Public Law 115–232](#), section 889, covered telecommunications equipment is telecommunications equipment produced by Huawei Technologies Company or ZTE Corporation (or any subsidiary or affiliate of such entities).
    - (i) For the purpose of public safety, security of government facilities, physical security surveillance of critical infrastructure, and other national security purposes, video surveillance and telecommunications equipment produced by Hytera Communications Corporation, Hangzhou Hikvision Digital Technology Company, or Dahua Technology Company (or any subsidiary or affiliate of such entities).
    - (ii) Telecommunications or video surveillance services provided by such entities or using such equipment.
    - (iii) Telecommunications or video surveillance equipment or services produced or provided by an entity that the Secretary of Defense, in consultation with the Director of the National Intelligence or the Director of the Federal Bureau of Investigation, reasonably believes to be an entity owned or controlled by, or otherwise connected to, the government of a covered foreign country.
- (b) In implementing the prohibition under [Public Law 115–232](#), section 889, subsection (f), paragraph (1), heads of executive agencies administering loan, grant, or subsidy programs shall prioritize available funding and technical support to assist affected businesses, institutions and organizations as is reasonably necessary for those affected entities to transition from covered communications equipment and services, to procure replacement equipment and services, and to ensure that communications service to users and customers is sustained.
- (c) See [Public Law 115–232](#), section 889 for additional information.
- (d) See also [§ 200.471](#).

#### Resources:

[2 CRF 200.216](#)

FAQ's: [Sec. 889 of 2019 NDAA FAQ 20201124.pdf \(performance.gov\)](#)

[Public Law 115-232, Section 889](#)

[§ 200.471](#)

## **Davis-Bacon Wage Rate Requirements**

(required contract provision)

### **Background and Applicability**

On October 30, 2009, P.L. 111-88, "Making appropriations for the Department of the Interior, environment, and related agencies for the fiscal year ending September 30, 2010, and for other purposes," was enacted. This law provides appropriations for both the Clean Water State Revolving Fund (CWSRF) and the Drinking Water State Revolving Fund (DWSRF) for Fiscal Year 2010, while adding new requirements to these already existing programs. One new requirement requires the application of Davis-Bacon Act requirements.

Application of the Davis-Bacon Act requirements extend not only to assistance agreements funded with Fiscal Year 2010 appropriations, but to all assistance agreements executed on or after October 30, 2009, whether the source of the funding is prior year's appropriations, state match, bond proceeds, interest earnings, principal repayments, or any other source of funding so long as the project is financed by an SRF assistance agreement. If a project began construction prior to October 30, 2009 but is financed or refinanced through an assistance agreement executed on or after October 30, 2009, Davis-Bacon Act requirements will apply to all construction that occurs on or after October 30, 2009, through completion of construction.

### **Ohio EPA Responsibilities**

With respect to the Water Pollution Control Loan Fund (WPCLF) and Water Supply Revolving Loan Account (WSRLA) revolving funds, EPA provides capitalization grants to each State which in turn provides funding assistance to eligible recipients within the State. Typically, the assistance recipients are municipal or other local governmental entities that manage the funds. Occasionally, the assistance recipients may be a private for profit or not for profit entity. Although EPA and the State are responsible for ensuring assistance recipients incorporate the wage rate requirements set forth herein as part of contracts for WPCLF and WSRLA funding, the assistance recipient has the primary responsibility to maintain payroll records and for compliance with Davis-Bacon Act requirements as described below.

### **Municipal Or Other Local Governmental Entities Recipient's Responsibilities**

The following is intended to help assistance recipients understand and meet their obligations related to Davis-Bacon (DB). Each assistance recipients should, however, review the contract/subcontract requirements that are set forth later in this document for a more full understanding of DB obligations.

#### **Prior to advertising for bids:**

- > Obtain the wage determination for the locality in which a covered activity subject to DB will take place from the Department of Labor (DOL) at [www.wdol.gov](http://www.wdol.gov).
- > Incorporate these wage determinations into the request for bids.
- > Include the required contract provisions (see below) into the contract documents.
- > Require prime contracts to include provisions that subcontractors follow the wage determination incorporated into the prime contract.

### **During the advertisement period:**

- > Monitor [www.wdol.gov](http://www.wdol.gov) on a weekly basis to ensure that the wage determination contained in the request for bids remains current.
- > If DOL modifies the DB wage determination more than 10 days prior to the bid opening, issue an addendum reflecting the modification.
- > If DOL modifies or supersedes the DB wage determination less than 10 days prior to bid opening and you cannot issue an addendum for the change, you must request a finding from Ohio EPA that there is not reasonable time to notify interested contractors of the modification of the wage determination. The Ohio EPA will give you a report of its findings.

### **After opening bids:**

- > If the contract(s) aren't awarded within 90 days of the bid opening you must monitor [www.wdol.gov](http://www.wdol.gov) on a weekly basis to ensure that wage determinations used in the bids remain current.
- > If the contract(s) aren't awarded within 90 days of the bid opening, any modifications or supersedes that DOL makes to the wage determination must be incorporated into the contract unless (1) you request an extension from Ohio EPA AND (2) Ohio EPA obtains an extension of the 90 day period from DOL pursuant to 29 CFR 1.6(c)(3)(iv).

### **After contracts are signed and during construction:**

- > Review all subcontracts subject to DB entered into by prime contractors to verify that the prime contractor has required its subcontractors to include the applicable wage determinations.
- > DOL may issue a revised wage determination applicable to one or all of your contracts after the award of the contract or execution of the change order which incorporated DB requirements into the contract if DOL determines that you have failed to incorporate a wage determination or have used a wage determination that clearly does not apply to the contract. If this occurs, you shall either terminate the contract or change order and rebid the contract OR incorporate DOL's wage determination retroactive to the beginning of the contract by change order. The contractor must be compensated for any increases in wages resulting from the use of DOL's revised wage determination.
- > Periodically interview a sufficient number of employees entitled to DB prevailing wages (covered employees) to verify that contractors or subcontractors are paying the appropriate wage rates. As provided in 29 CFR 5.6(a)(6), all interviews must be conducted in confidence. You must use Standard Form 1445 or equivalent documentation to memorialize the interviews.
- > Establish and follow an interview schedule based on its assessment of the risks of noncompliance with DB posed by contractors or subcontractors and the duration of the contract or subcontract. At a minimum, you must:
  - conduct all interviews in confidence.
  - conduct interviews with a representative group of covered employees within two weeks of each contractor or subcontractor's submission of its initial weekly payroll data and two weeks prior to the estimated completion date for the contract or subcontract.
  - conduct more frequent interviews if the initial interviews or other information indicates that there is a risk that the contractor or subcontractor is not complying with DB.
  - immediately conduct necessary interviews in response to an alleged violation of the prevailing wage requirements.
- > Periodically conduct spot checks of a representative sample of weekly payroll data to verify that contractors or subcontractors are paying the appropriate wage rates. You must:
  - establish and follow a spot check schedule based on your assessment of the risks of noncompliance with DB posed by contractors or subcontractors and the duration of the contract or subcontract.
  - spot check payroll data within two weeks of each contractor or subcontractor's submission of its initial payroll data and two weeks prior to the completion date the contract or subcontract at a minimum.
  - conduct more frequent spot checks if the initial spot check or other information indicates that there



is a risk that the contractor or subcontractor is not complying with DB.

- during the examinations, verify evidence of fringe benefit plans and payments thereunder by contractors and subcontractors who claim credit for fringe benefit contributions.

> Periodically review contractors' and subcontractors' use of apprentices and trainees to verify registration and certification with respect to apprenticeship and training programs approved by either the DOL or a state, as appropriate, and that contractors and subcontractors are not using disproportionate numbers of, laborers, trainees and apprentices. These reviews shall be conducted in accordance with the schedules for spot checks and interviews.

> Immediately report potential violations of the DB prevailing wage requirements to Andrew Lausted at EPA Region V at 312-886-0189 and to the appropriate DOL Wage and Hour District Office listed at <http://www.dol.gov/esa/contacts/whd/america2.htm>.

**If contracts have already been signed and DB requirements need to be incorporated:**

> If contracts have already been signed prior to WPCLF/WSRLA funding being provided, you must issue a change order, task order, work assignment or similar legally binding instrument and incorporate the appropriate DOL wage determination from [www.wdol.gov](http://www.wdol.gov) as well as the required contract provisions into the contract(s).

> Initiate the contractor and subcontractor review and wage interview requirements as described above and provided in the **Contract And Subcontract Provisions**.

**Private For Profit Or Not For Profit (Non-Governmental) Entities  
Recipient's Responsibilities**

The requirements, responsibilities and contract provisions for Private For Profit or Not For Profit Entities (Non-Governmental Entities) is exactly the same as for Municipal Or Other Local Governmental Entities EXCEPT for the following:

**Prior to advertising for bids:**

> Obtain the proposed wage determinations for specific localities from [www.wdol.gov](http://www.wdol.gov).

> Submit the wage determination to Ohio EPA for approval prior to inserting the wage determination into the solicitation unless subsequently directed otherwise by Ohio EPA.

**Contract And Subcontract Provisions For Contracts In Excess Of \$2,000**

The following language must be included in full in any contract in excess of \$2,000 which is entered into for the actual construction, alteration and/or repair, including painting and decorating, of a public building or public work, or building or work financed in whole or in part with WPCLF or WSRLA funds and which is subject to the labor standards provisions of any of the acts listed in §5.1:

**NOTE: Modify the first sentence to include the name of the WPCLF/WSRLA funding recipient prior to including these provisions in the contract documents.**

**Wage Rate Requirements**

As used in these provisions "subrecipient" means \_\_\_\_\_ (fill in WPCLF/WSRLA funding recipient name here).

*(a) The following applies to any contract in excess of \$2,000 which is entered into for the actual construction, alteration and/or repair, including painting and decorating, of a public building or public*

*work, or building or work financed in whole or in part from Federal funds or in accordance with guarantees of a Federal agency or financed from funds obtained by pledge of any contract of a Federal agency to make a loan, grant or annual contribution (except where a different meaning is expressly indicated), and which is subject to the labor standards provisions of any of the acts listed in § 5.1.*

*(1) Minimum wages.*

*(i) All laborers and mechanics employed or working upon the site of the work will be paid unconditionally and not less often than once a week, and without subsequent deduction or rebate on any account (except such payroll deductions as are permitted by regulations issued by the Secretary of Labor under the Copeland Act (29 CFR part 3) ), the full amount of wages and bona fide fringe benefits (or cash equivalents thereof) due at time of payment computed at rates not less than those contained in the wage determination of the Secretary of Labor which is attached hereto and made a part hereof, regardless of any contractual relationship which may be alleged to exist between the contractor and such laborers and mechanics.*

*Contributions made or costs reasonably anticipated for bona fide fringe benefits under section 1(b)(2) of the Davis-Bacon Act on behalf of laborers or mechanics are considered wages paid to such laborers or mechanics, subject to the provisions of paragraph (a)(1)(iv) of this section; also, regular contributions made or costs incurred for more than a weekly period (but not less often than quarterly) under plans, funds, or programs which cover the particular weekly period, are deemed to be constructively made or incurred during such weekly period. Such laborers and mechanics shall be paid the appropriate wage rate and fringe benefits on the wage determination for the classification of work actually performed, without regard to skill, except as provided in § 5.5(a)(4). Laborers or mechanics performing work in more than one classification may be compensated at the rate specified for each classification for the time actually worked therein: Provided, that the employer's payroll records accurately set forth the time spent in each classification in which work is performed. The wage determination (including any additional classification and wage rates conformed under paragraph (a)(1)(ii) of this section) and the Davis-Bacon poster (WH-1321) shall be posted at all times by the contractor and its subcontractors at the site of the work in a prominent and accessible place where it can be easily seen by the workers.*

*Subrecipients may obtain wage determinations from the U.S. Department of Labor's web site, [www.wdol.gov](http://www.wdol.gov).*

*(ii)(A) The subrecipient(s), on behalf of EPA, shall require that any class of laborers or mechanics, including helpers, which is not listed in the wage determination and which is to be employed under the contract shall be classified in conformance with the wage determination. The EPA award official shall approve an additional classification and wage rate and fringe benefits therefore only when the following criteria have been met:*

*(1) The work to be performed by the classification requested is not performed by a classification in the wage determination; and*

*(2) The classification is utilized in the area by the construction industry; and*

*(3) The proposed wage rate, including any bona fide fringe benefits, bears a reasonable relationship to the wage rates contained in the wage determination.*

*(B) If the contractor and the laborers and mechanics to be employed in the classification (if known), or their representatives, and the subrecipient(s) agree on the classification and wage rate (including the amount designated for fringe benefits where appropriate), a report of the action taken shall be sent by the subrecipient(s) to the State award official. The State award official will transmit the report, to the Administrator of the Wage and Hour Division, Employment Standards Administration, U.S. Department*

*of Labor, Washington, DC 20210. The Administrator, or an authorized representative, will approve, modify, or disapprove every additional classification action within 30 days of receipt and so advise the State award official or will notify the State award official within the 30-day period that additional time is necessary.*

*(C) In the event the contractor, the laborers or mechanics to be employed in the classification or their representatives, and the and the subrecipient(s) do not agree on the proposed classification and wage rate (including the amount designated for fringe benefits, where appropriate), the award official shall refer the questions, including the views of all interested parties and the recommendation of the State award official, to the Administrator for determination. The Administrator, or an authorized representative, will issue a determination within 30 days of receipt and so advise the contracting officer or will notify the contracting officer within the 30-day period that additional time is necessary.*

*(D) The wage rate (including fringe benefits where appropriate) determined pursuant to paragraphs (a)(1)(ii)(B) or (C) of this section, shall be paid to all workers performing work in the classification under this contract from the first day on which work is performed in the classification.*

*(iii) Whenever the minimum wage rate prescribed in the contract for a class of laborers or mechanics includes a fringe benefit which is not expressed as an hourly rate, the contractor shall either pay the benefit as stated in the wage determination or shall pay another bona fide fringe benefit or an hourly cash equivalent thereof.*

*(iv) If the contractor does not make payments to a trustee or other third person, the contractor may consider as part of the wages of any laborer or mechanic the amount of any costs reasonably anticipated in providing bona fide fringe benefits under a plan or program, Provided, That the Secretary of Labor has found, upon the written request of the contractor, that the applicable standards of the Davis-Bacon Act have been met. The Secretary of Labor may require the contractor to set aside in a separate account asset for the meeting of obligations under the plan or program.*

*(2) Withholding. The subrecipient(s), shall upon written request of the EPA Award Official or an authorized representative of the Department of Labor, withhold or cause to be withheld from the contractor under this contract or any other Federal contract with the same prime contractor, or any other federally-assisted contract subject to Davis-Bacon prevailing wage requirements, which is held by the same prime contractor, so much of the accrued payments or advances as may be considered necessary to pay laborers and mechanics, including apprentices, trainees, and helpers, employed by the contractor or any subcontractor the full amount of wages required by the contract. In the event of failure to pay any laborer or mechanic, including any apprentice, trainee, or helper, employed or working on the site of the work, all or part of the wages required by the contract, the (Agency) may, after written notice to the contractor, sponsor, applicant, or owner, take such action as may be necessary to cause the suspension of any further payment, advance, or guarantee of funds until such violations have ceased.*

*(3) Payrolls and basic records.*

*(i) Payrolls and basic records relating thereto shall be maintained by the contractor during the course of the work and preserved for a period of three years thereafter for all laborers and mechanics working at the site of the work. Such records shall contain the name, address, and social security number of each such worker, his or her correct classification, hourly rates of wages paid (including rates of contributions or costs anticipated for bona fide fringe benefits or cash equivalents thereof of the types described in section 1(b)(2)(B) of the Davis-Bacon Act), daily and weekly number of hours worked, deductions made and actual wages paid. Whenever the Secretary of Labor has found under 29 CFR 5.5(a)(1)(iv) that the wages of any laborer or mechanic include the amount of any costs reasonably anticipated in providing benefits under a plan or program described in section 1(b)(2)(B) of the Davis-Bacon Act, the contractor shall maintain records which show that the commitment to provide such benefits is enforceable, that the*

*plan or program is financially responsible, and that the plan or program has been communicated in writing to the laborers or mechanics affected, and records which show the costs anticipated or the actual cost incurred in providing such benefits. Contractors employing apprentices or trainees under approved programs shall maintain written evidence of the registration of apprenticeship programs and certification of trainee programs, the registration of the apprentices and trainees, and the ratios and wage rates prescribed in the applicable programs.*

*(ii)(A) The contractor shall submit weekly, for each week in which any contract work is performed, a copy of all payrolls to the subrecipient, that is, the entity that receives the subgrant or loan from the State capitalization grant recipient. Such documentation shall be available on request of the State recipient or EPA. As to each payroll copy received, the subrecipient shall provide written confirmation in a form satisfactory to the State indicating whether or not the project is in compliance with the requirements of 29 CFR 5.5(a)(1) based on the most recent payroll copies for the specified week. The payrolls shall set out accurately and completely all of the information required to be maintained under 29 CFR 5.5(a)(3)(i), except that full social security numbers and home addresses shall not be included on the weekly payrolls. Instead the payrolls shall only need to include an individually identifying number for each employee (e.g., the last four digits of the employee's social security number). The required weekly payroll information may be submitted in any form desired. Optional Form WH-347 is available for this purpose from the Wage and Hour Division Web site at <http://www.dol.gov/esa/whd/forms/wh347instr.htm> or its successor site. The prime contractor is responsible for the submission of copies of payrolls by all subcontractors. Contractors and subcontractors shall maintain the full social security number and current address of each covered worker, and shall provide them upon request to the subrecipient(s) for transmission to the State or EPA if requested by EPA, the State, the contractor, or the Wage and Hour Division of the Department of Labor for purposes of an investigation or audit of compliance with prevailing wage requirements. It is not a violation of this section for a prime contractor to require a subcontractor to provide addresses and social security numbers to the prime contractor for its own records, without weekly submission to the subrecipient(s).*

*(B) Each payroll submitted shall be accompanied by a "Statement of Compliance," signed by the contractor or subcontractor or his or her agent who pays or supervises the payment of the persons employed under the contract and shall certify the following:*

*(1) That the payroll for the payroll period contains the information required to be provided under § 5.5 (a)(3)(ii) of Regulations, 29 CFR part 5, the appropriate information is being maintained under § 5.5 (a)(3)(i) of Regulations, 29 CFR part 5, and that such information is correct and complete;*

*(2) That each laborer or mechanic (including each helper, apprentice, and trainee) employed on the contract during the payroll period has been paid the full weekly wages earned, without rebate, either directly or indirectly, and that no deductions have been made either directly or indirectly from the full wages earned, other than permissible deductions as set forth in Regulations, 29 CFR part 3;*

*(3) That each laborer or mechanic has been paid not less than the applicable wage rates and fringe benefits or cash equivalents for the classification of work performed, as specified in the applicable wage determination incorporated into the contract.*

*(C) The weekly submission of a properly executed certification set forth on the reverse side of Optional Form WH-347 shall satisfy the requirement for submission of the "Statement of Compliance" required by paragraph (a)(3)(ii)(B) of this section.*

*(D) The falsification of any of the above certifications may subject the contractor or subcontractor to civil or criminal prosecution under section 1001 of title 18 and section 231 of title 31 of the United States Code.*

*(iii) The contractor or subcontractor shall make the records required under paragraph (a)(3)(i) of this section available for inspection, copying, or transcription by authorized representatives of the State, EPA or the Department of Labor, and shall permit such representatives to interview employees during working hours on the job. If the contractor or subcontractor fails to submit the required records or to make them available, the Federal agency or State may, after written notice to the contractor, sponsor, applicant, or owner, take such action as may be necessary to cause the suspension of any further payment, advance, or guarantee of funds. Furthermore, failure to submit the required records upon request or to make such records available may be grounds for debarment action pursuant to 29 CFR 5.12.*

*(4) Apprentices and trainees --*

*(i) Apprentices. Apprentices will be permitted to work at less than the predetermined rate for the work they performed when they are employed pursuant to and individually registered in a bona fide apprenticeship program registered with the U.S. Department of Labor, Employment and Training Administration, Office of Apprenticeship Training, Employer and Labor Services, or with a State Apprenticeship Agency recognized by the Office, or if a person is employed in his or her first 90 days of probationary employment as an apprentice in such an apprenticeship program, who is not individually registered in the program, but who has been certified by the Office of Apprenticeship Training, Employer and Labor Services or a State Apprenticeship Agency (where appropriate) to be eligible for probationary employment as an apprentice. The allowable ratio of apprentices to journeymen on the job site in any craft classification shall not be greater than the ratio permitted to the contractor as to the entire work force under the registered program. Any worker listed on a payroll at an apprentice wage rate, who is not registered or otherwise employed as stated above, shall be paid not less than the applicable wage rate on the wage determination for the classification of work actually performed. In addition, any apprentice performing work on the job site in excess of the ratio permitted under the registered program shall be paid not less than the applicable wage rate on the wage determination for the work actually performed. Where a contractor is performing construction on a project in a locality other than that in which its program is registered, the ratios and wage rates (expressed in percentages of the journeyman's hourly rate) specified in the contractor's or subcontractor's registered program shall be observed. Every apprentice must be paid at not less than the rate specified in the registered program for the apprentice's level of progress, expressed as a percentage of the journeymen hourly rate specified in the applicable wage determination. Apprentices shall be paid fringe benefits in accordance with the provisions of the apprenticeship program. If the apprenticeship program does not specify fringe benefits, apprentices must be paid the full amount of fringe benefits listed on the wage determination for the applicable classification. If the Administrator determines that a different practice prevails for the applicable apprentice classification, fringes shall be paid in accordance with that determination. In the event the Office of Apprenticeship Training, Employer and Labor Services, or a State Apprenticeship Agency recognized by the Office, withdraws approval of an apprenticeship program, the contractor will no longer be permitted to utilize apprentices at less than the applicable predetermined rate for the work performed until an acceptable program is approved.*

*(ii) Trainees. Except as provided in 29 CFR 5.16, trainees will not be permitted to work at less than the predetermined rate for the work performed unless they are employed pursuant to and individually registered in a program which has received prior approval, evidenced by formal certification by the U.S. Department of Labor, Employment and Training Administration. The ratio of trainees to journeymen on the job site shall not be greater than permitted under the plan approved by the Employment and Training Administration. Every trainee must be paid at not less than the rate specified in the approved program for the trainee's level of progress, expressed as a percentage of the journeyman hourly rate specified in the applicable wage determination. Trainees shall be paid fringe benefits in accordance with the provisions of the trainee program. If the trainee program does not mention fringe benefits, trainees shall be paid the full amount of fringe benefits listed on the wage determination unless the Administrator of the Wage and Hour Division determines that there is an apprenticeship program associated with the corresponding journeyman wage rate on the wage determination which provides for less than full fringe*

*benefits for apprentices. Any employee listed on the payroll at a trainee rate who is not registered and participating in a training plan approved by the Employment and Training Administration shall be paid not less than the applicable wage rate on the wage determination for the classification of work actually performed. In addition, any trainee performing work on the job site in excess of the ratio permitted under the registered program shall be paid not less than the applicable wage rate on the wage determination for the work actually performed. In the event the Employment and Training Administration withdraws approval of a training program, the contractor will no longer be permitted to utilize trainees at less than the applicable predetermined rate for the work performed until an acceptable program is approved.*

*(iii) Equal employment opportunity. The utilization of apprentices, trainees and journeymen under this part shall be in conformity with the equal employment opportunity requirements of Executive Order 11246, as amended, and 29 CFR part 30.*

*(5) Compliance with Copeland Act requirements. The contractor shall comply with the requirements of 29 CFR part 3, which are incorporated by reference in this contract.*

*(6) Subcontracts. The contractor or subcontractor shall insert in any subcontracts the clauses contained in 29 CFR 5.5(a)(1) through (10) and such other clauses as the EPA determines may be appropriate, and also a clause requiring the subcontractors to include these clauses in any lower tier subcontracts. The prime contractor shall be responsible for the compliance by any subcontractor or lower tier subcontractor with all the contract clauses in 29 CFR 5.5.*

*(7) Contract termination: debarment. A breach of the contract clauses in 29 CFR 5.5 may be grounds for termination of the contract, and for debarment as a contractor and a subcontractor as provided in 29 CFR 5.12.*

*(8) Compliance with Davis-Bacon and Related Act requirements. All rulings and interpretations of the Davis-Bacon and Related Acts contained in 29 CFR parts 1, 3, and 5 are herein incorporated by reference in this contract.*

*(9) Disputes concerning labor standards. Disputes arising out of the labor standards provisions of this contract shall not be subject to the general disputes clause of this contract. Such disputes shall be resolved in accordance with the procedures of the Department of Labor set forth in 29 CFR parts 5, 6, and 7. Disputes within the meaning of this clause include disputes between the contractor (or any of its subcontractors) and subrecipient(s), State, EPA, the U.S. Department of Labor, or the employees or their representatives.*

*(10) Certification of eligibility.*

*(i) By entering into this contract, the contractor certifies that neither it (nor he or she) nor any person or firm who has an interest in the contractor's firm is a person or firm ineligible to be awarded Government contracts by virtue of section 3(a) of the Davis-Bacon Act or 29 CFR 5.12(a)(1).*

*(ii) No part of this contract shall be subcontracted to any person or firm ineligible for award of a Government contract by virtue of section 3(a) of the Davis-Bacon Act or 29 CFR 5.12(a)(1).*

*(iii) The penalty for making false statements is prescribed in the U.S. Criminal Code, 18 U.S.C. 1001.*

**Contract Provision For Contracts In Excess Of \$100,000 And Subject To The Overtime Provisions Of The Contract Work Hours And Safety Standards Act**

The following language must be included in full in any contract in an amount in excess of \$100,000 and subject to the overtime provisions of the Contract Work Hours and Safety Standards Act. These provisions are to be included in addition to the provisions for contracts in excess of \$2,000. As used in these paragraphs, the terms laborers and mechanics include watchmen and guards.

*(b) Contract Work Hours and Safety Standards Act. The following applies to any contract in an amount in excess of \$100,000 and subject to the overtime provisions of the Contract Work Hours and Safety Standards Act. As used in these paragraphs, the terms laborers and mechanics include watchmen and guards.*

*(1) Overtime requirements. No contractor or subcontractor contracting for any part of the contract work which may require or involve the employment of laborers or mechanics shall require or permit any such laborer or mechanic in any workweek in which he or she is employed on such work to work in excess of forty hours in such workweek unless such laborer or mechanic receives compensation at a rate not less than one and one-half times the basic rate of pay for all hours worked in excess of forty hours in such workweek.*

*(2) Violation; liability for unpaid wages; liquidated damages. In the event of any violation of the clause set forth in paragraph (b)(1) of this section the contractor and any subcontractor responsible therefore shall be liable for the unpaid wages. In addition, such contractor and subcontractor shall be liable to the United States (in the case of work done under contract for the District of Columbia or a territory, to such District or to such territory), for liquidated damages. Such liquidated damages shall be computed with respect to each individual laborer or mechanic, including watchmen and guards, employed in violation of the clause set forth in paragraph (a)(1) of this section, in the sum of \$10 for each calendar day on which such individual was required or permitted to work in excess of the standard workweek of forty hours without payment of the overtime wages required by the clause set forth in paragraph (b)(1) of this section.*

*(3) Withholding for unpaid wages and liquidated damages. The subrecipient, upon written request of the EPA Award Official or an authorized representative of the Department of Labor, shall withhold or cause to be withheld, from any moneys payable on account of work performed by the contractor or subcontractor under any such contract or any other Federal contract with the same prime contractor, or any other federally-assisted contract subject to the Contract Work Hours and Safety Standards Act, which is held by the same prime contractor, such sums as may be determined to be necessary to satisfy any liabilities of such contractor or subcontractor for unpaid wages and liquidated damages as provided in the clause set forth in paragraph (b)(2) of this section.*

*(4) Subcontracts. The contractor or subcontractor shall insert in any subcontracts the clauses set forth in paragraph (b)(1) through (4) of this section and also a clause requiring the subcontractors to include these clauses in any lower tier subcontracts. The prime contractor shall be responsible for compliance by any subcontractor or lower tier subcontractor with the clauses set forth in paragraphs (b)(1) through (4) of this section.*

**Contract Provision For Contracts In Excess Of \$100,000 Subject ONLY To The Contract Work Hours And Safety Standards Act**

In addition to the provisions for contracts in excess of \$2,000, for any contract subject only to the Contract Work Hours and Safety Standards Act and not to any of the other statutes cited in 29 CFR 5.1, you must insert clauses requiring:

*(c) The following applies to any contract subject only to the Contract Work Hours and Safety Standards Act and not to any of the other statutes cited in 29 CFR 5.1.*

*The contractor or subcontractor shall maintain payrolls and basic payroll records during the course of the work and shall preserve them for a period of three years from the completion of the contract for all laborers and mechanics, including guards and watchmen, working on the contract. Such records shall contain the name and address of each such employee, social security number, correct classifications, hourly rates of wages paid, daily and weekly number of hours worked, deductions made, and actual wages paid.*

*The records shall be maintained under this paragraph shall be made available by the contractor or subcontractor for inspection, copying, or transcription by authorized representatives of the Ohio EPA, EPA and the Department of Labor, and the contractor or subcontractor will permit such representatives to interview employees during working hours on the job.*





U.S. Department of Labor  
Wage and Hour Division

PAYROLL

(For Contractor's Optional Use; See Instructions at www.dol.gov/whd/forms/wh347instr.htm)

Persons are not required to respond to the collection of information unless it displays a currently valid OMB control number.

Rev. Dec. 2008

NAME OF CONTRACTOR OR SUBCONTRACTOR ADDRESS PROJECT AND LOCATION PROJECT OR CONTRACT NO. OMB No.: 1235-0008 Expires: 02/28/2018

PAYROLL NO. FOR WEEK ENDING

Table with columns: (1) NAME AND INDIVIDUAL IDENTIFYING NUMBER (e.g., LAST FOUR DIGITS OF SOCIAL SECURITY NUMBER) OF WORKER; (2) EXEMPTIONS OR WITHHOLDING; (3) WORK CLASSIFICATION; (4) DAY AND DATE; (5) HOURS WORKED EACH DAY; (6) RATE OF PAY; (7) GROSS AMOUNT EARNED; (8) DEDUCTIONS (FICA, WITH-HOLDING TAX, OTHER, TOTAL DEDUCTIONS); (9) NET WAGES PAID FOR WEEK.

DB.11

While completion of Form WH-347 is optional, it is mandatory for covered contractors and subcontractors performing work on Federally financed or assisted construction contracts to respond to the information collection contained in 29 C.F.R. §§ 3.3, 5.5(a). The Copeland Act (40 U.S.C. § 3145) contractors and subcontractors performing work on Federally financed or assisted construction contracts to "furnish weekly a statement with respect to the wages paid each employee during the preceding week." U.S. Department of Labor (DOL) regulations at 29 C.F.R. § 5.5(a)(3)(ii) require contractors to submit weekly a copy of all payrolls to the Federal agency contracting for or financing the construction project, accompanied by a signed "Statement of Compliance" indicating that the payrolls are correct and complete and that each laborer or mechanic has been paid not less than the proper Davis-Bacon prevailing wage rate for the work performed. DOL and federal contracting agencies receiving this information review the information to determine that employees have received legally required wages and fringe benefits.

Public Burden Statement

We estimate that it will take an average of 55 minutes to complete this collection, including time for reviewing instructions, searching existing data sources, gathering and maintaining the data needed, and completing and reviewing the collection of information. If you have any comments regarding these estimates or any other aspect of this collection, including suggestions for reducing this burden, send them to the Administrator, Wage and Hour Division, U.S. Department of Labor, Room S3502, 200 Constitution Avenue, N.W. Washington, D.C. 20210

(over)

Date \_\_\_\_\_

I, \_\_\_\_\_ (Name of Signatory Party) \_\_\_\_\_ (Title) do hereby state:

(1) That I pay or supervise the payment of the persons employed by \_\_\_\_\_ (Contractor or Subcontractor) on the \_\_\_\_\_ (Building or Work); that during the payroll period commencing on the \_\_\_\_\_ day of \_\_\_\_\_, \_\_\_\_\_, and ending the \_\_\_\_\_ day of \_\_\_\_\_, all persons employed on said project have been paid the full weekly wages earned, that no rebates have been or will be made either directly or indirectly to or on behalf of said \_\_\_\_\_ (Contractor or Subcontractor) from the full

weekly wages earned by any person and that no deductions have been made either directly or indirectly from the full wages earned by any person, other than permissible deductions as defined in Regulations, Part 3 (29 C.F.R. Subtitle A), issued by the Secretary of Labor under the Copeland Act, as amended (48 Stat. 948, 63 Stat. 108, 72 Stat. 967; 40 U.S.C. § 3145), and described below:

DB. 2

\_\_\_\_\_  
 \_\_\_\_\_  
 \_\_\_\_\_

(2) That any payrolls otherwise under this contract required to be submitted for the above period are correct and complete; that the wage rates for laborers or mechanics contained therein are not less than the applicable wage rates contained in any wage determination incorporated into the contract; that the classifications set forth therein for each laborer or mechanic conform with the work he performed.

(3) That any apprentices employed in the above period are duly registered in a bona fide apprenticeship program registered with a State apprenticeship agency recognized by the Bureau of Apprenticeship and Training, United States Department of Labor, or if no such recognized agency exists in a State, are registered with the Bureau of Apprenticeship and Training, United States Department of Labor.

(4) That: (a) WHERE FRINGE BENEFITS ARE PAID TO APPROVED PLANS, FUNDS, OR PROGRAMS

— in addition to the basic hourly wage rates paid to each laborer or mechanic listed in the above referenced payroll, payments of fringe benefits as listed in the contract have been or will be made to appropriate programs for the benefit of such employees, except as noted in section 4(c) below.

(b) WHERE FRINGE BENEFITS ARE PAID IN CASH

— Each laborer or mechanic listed in the above referenced payroll has been paid, as indicated on the payroll, an amount not less than the sum of the applicable basic hourly wage rate plus the amount of the required fringe benefits as listed in the contract, except as noted in section 4(c) below.

(c) EXCEPTIONS

EXCEPTION (CRAFT)	EXPLANATION

REMARKS:

NAME AND TITLE	SIGNATURE
THE WILLFUL FALSIFICATION OF ANY OF THE ABOVE STATEMENTS MAY SUBJECT THE CONTRACTOR OR SUBCONTRACTOR TO CIVIL OR CRIMINAL PROSECUTION. SEE SECTION 1001 OF TITLE 18 AND SECTION 231 OF TITLE 31 OF THE UNITED STATES CODE.	

## How to Correctly Fill Out a WH-347 Payroll Form

The completion of the WH-347 Payroll Form is optional; contractors may utilize their own payroll system as long as it conforms to the WH-347 Payroll Form and contains all the necessary information. If you utilize WH-347 Payroll Form as a pdf, saving it electronically aids in making any needed corrections.

Check one of the boxes and list name of contractor or subcontractor

The last day of the payroll period.

Fill out completely with contractor or subcontractor address

**U.S. Department of Labor**  
Employment Standards Administration  
Wage and Hour Division

**PAYROLL**  
(For Contractor's Optional Use; See instructions at [www.dol.gov/esa/whd/forms/wh347instr.htm](http://www.dol.gov/esa/whd/forms/wh347instr.htm))  
Persons are not required to respond to the collection of information unless it displays a currently valid OMB control number.

**WHD**  
U.S. Wage and Hour Division  
Rev. Dec. 2008

NAME OF CONTRACTOR  OR SUBCONTRACTOR    
Sample Construction Company

ADDRESS 385 West Drive, Madison WI 53703

OMB No.: 1215-0149  
Expires: 12/31/2011

PROJECT OR CONTRACT NO. 3000

PAYROLL NO. 8	NAME AND INDIVIDUAL IDENTIFYING NUMBER (e.g. LAST FOUR DIGITS OF SOCIAL SECURITY NUMBER) OF WORKER	WORK CLASSIFICATION	(4) DAY AND DATE							(5) TOTAL HOURS	(6) RATE OF PAY	(7) GROSS AMOUNT EARNED	(8) DEDUCTIONS			(9) NET WAGES FOR WEEK	
			Sun	Mon	Tue	Wed	Thur	Frid	Sat				State withholding tax	Medicare	OTHER DEDUCTIONS		
	Alex Driver - ###	Power Equipment Operator Bull Dozer Group 12							2.00	\$62.83	\$125.66	\$185.15	\$156.97	\$50.31	\$85.00	\$24.43	\$1,374.03
			8.00	9.00	5.00	6.00			27.50	\$1.32	\$36.30						

FOR WEEK ENDING 04/24/2010

PROJECT AND LOCATION: Robin Street Apartments, Delafield WI 53018

The prime contractor should include the project number as listed in the loan

The name and location of project.

Indicate the days and dates of the pay period. (should match week ending directly above)

Payrolls must be numbered sequentially and should be based on the weeks worked under a contract.  
Type the word "Final" when the last payroll is submitted for the project.

List each worker's name.

Only laborers and mechanics performing construction work under the contract should be listed.

Please note: Business Owners need only include their name, work classification including "owner" and the daily total hours worked.

Specify the job classification located in the contract wage decision and/or the corresponding job title.

List hourly wage rate and fringes paid in cash (not those paid to plans)

(For Contractors' Optional Use) See instructions at [www.dol.gov/esa/whd/forms/wh347instr.htm](http://www.dol.gov/esa/whd/forms/wh347instr.htm)

Persons are not required to respond to the collection of information unless it displays a currently valid OMB control number.



Specify the net amount paid to the employee for the pay

Specify the total overtime and straight time hours worked on the project.

Must accurately reflect overtime and straight time hours worked under the contract.

Specify the gross earnings for the hours worked under the contract.

NAME AND INDIVIDUAL IDENTIFYING NUMBER (6, 9, LAST FOUR DIGITS OF SOCIAL SECURITY NUMBER OF WORKER)	WORK CLASSIFICATION	(4) DAY AND DATE							TOTAL HOURS	RATE OF PAY	GROSS AMOUNT EARNED	(8) DEDUCTIONS			TOTAL DEDUCTIONS	NET WAGES PAID FOR WEEK
		Sun	Mon	Tue	Wed	Thurs	Frid	Sat				WITHH.	FICA	OTHER		
Alex Driver - ####	Power Equipment Operator Bull Dozer Group 2							3.00	\$62.83	\$1,422.84	\$161.00			\$538.43	\$1,374.03	
Jason Worker - ####	General Laborer							4.00	\$45.20	\$1,702.78	\$136.06			\$1,233.07		
Steve Worker - ####	Carpenter							1.50	\$60.19	\$1,064.72	\$121.00	\$54.27	\$47.19	\$1,406.18		
Roy Wrench - ####	Apprentice Carpenter 1st 6 mo. at 40%							40.00	\$32.72	\$1,887.49	\$85.18	\$105.41	\$90.50	\$26.62	\$307.71	\$757.01
Bart Turner - ####	Plumber							40.00	\$121.44	\$1,064.72	\$163.46	\$147.11	\$118.51	\$51.08	\$480.16	\$1,563.04
	Steamfitter							20.00	\$67.88	\$1,004.80	\$115.93	\$142.48	\$122.33	\$55.98	\$415.93	\$1,023.27
	Power Equipment Operator Rotary Drill Group 4							24.00	\$29.97	\$1,439.20						

While completion of Form WH-347 is optional, it is mandatory for covered contractors and subcontractors performing work on Federally financed or assisted construction contracts to respond to (40 U.S.C. § 3145) contractors and subcontractors performing work on Federally financed or assisted construction contracts to furnish weekly a statement with respect to the wages paid each worker on the project. Contractors and subcontractors performing work on Federally financed or assisted construction contracts to furnish weekly a copy of a payroll to the Federal agency contracting for or financing the construction project, accompanied by a signed "Statement of Compliance" showing the proper Davis-Bacon prevailing wage rate for the work performed. DOL and federal contracting agencies receiving this information review the information for compliance with the Davis-Bacon Act.

Public Burden Statement

If part of a worker's weekly wage was earned on projects other than the project described on this payroll, enter the gross amount earned on this contract in the top half of column 7. Enter the gross amount earned during the week for all projects in the bottom half.

Alex Driver worked 29.5 hours on this contract and 12.5 hours on another contract. The gross wages earned on this project, \$1,422.84, is entered in the top half of column 7. The gross wages earned on all projects, \$2,012.46, is entered in the

(1) NAME AND INDIVIDUAL IDENTIFYING NUMBER (e.g., LAST FOUR DIGITS OF SOCIAL SECURITY NUMBER OF WORKER)	(2) JOB IDENTIFYING NUMBER	(3) WORK CLASSIFICATION	(4) DAY AND DATE							TOTAL HOURS	RATE OF PAY	GROSS AMOUNT EARNED	DEDUCTIONS				NET WAGES PAID FOR WEEK		
			HOURS WORKED EACH DAY										FICA	WITH- HOLDING TAX	State with- holding tax	Medicare		OTHER	TOTAL DEDUCTIONS
			Sun	Mon	Tue	Wed	Thur	Fri	Sat										
Alex Driver - ####	2	Power Equipment Bull Dozer Group 2								2.00	\$62.83	\$1,422.84	\$61.00	\$156.97	\$50.31	\$85.00	\$638.43	\$1,374.03	
Jason Worker - ####	2	General Laborer								4.00	\$40.70	\$2,012.46	\$35.06	\$132.66	\$42.52	\$467.71	\$1,233.07		
Sharon Wood - ####	3	Carpenter								1.50	\$60.19	\$1,700.78	\$151.00	\$154.77	\$47.19	\$481.31	\$1,406.18		
Reggie Tree - ####	1	Apprentice Carpenter 1st 6 mo. at 40%								40.00	\$32.72	\$1,064.72	\$85.18	\$105.41	\$90.50	\$307.71	\$757.01		
Roy Wrench - ####	5	Plumber								20.00	\$67.88	\$1,004.80							
Roy Wrench - ####	5	Steamfitter								20.00	\$69.13	\$1,038.40	\$163.46	\$147.11	\$118.51	\$480.16	\$1,563.04		
Bart Turner - ####	1	Power Equipment Rotary Drill Group 4								24.00	\$60.80	\$719.28	\$15.00	\$142.48	\$35.98	\$415.53	\$1,023.27		

If an employee performs multiple work classifications under the contract, use two or more lines to distinguish the different job classifications, hours worked, and hourly wage earned for each.

Combine the two classifications when recording the gross amount earned for this pay period, deductions, and net wages.



A registered apprentice performing work under a contract must be reported. The payroll must include the current pay scale & provide a copy of the apprenticeship agreement.

Provide explanation of "other" deductions on signatory page.

**PAYROLL**  
 Optional Use; See Instructions at [www.dol.gov/esa/whd/forms/wh347](http://www.dol.gov/esa/whd/forms/wh347)  
 used to respond to the collection of information unless it displays a currently valid OMB control number.  
 ADDRESS 385 West Drive, Madison WI 53703  
 Division 08  
 5-0149  
 Expires 2/23/2011

(1) NAME AND INDIVIDUAL IDENTIFYING NUMBER (e.g., LAST FOUR DIGITS OF SOCIAL SECURITY NUMBER OF WORKER)	(2) POSITION	(3) WORK CLASSIFICATION	(4) DAY AND DATE							(5) TOTAL HOURS	(6) RATE OF PAY	(7) GROSS AMOUNT EARNED	(8) DEDUCTIONS			(9) NET WAGES PAID FOR WEEK
			Sun	Mon	Tue	Wed	Thu	Frid	Sat				FICA	WITH- HOLDING TAX	State with Holding Tax	
Alex Driver - #####	2	Power Equipment Bull Dozer Group 2							2.00	\$62.83	\$125.66	\$161.00	\$156.97	\$50.31	\$85.00	\$1,374.03
Jason Worker - #####	2	General Laborer							4.00	\$49.20	\$196.80	\$136.06	\$132.66	\$42.52	\$467.71	\$1,233.07
Sharon Wood- #####	3	Carpenter							1.50	\$60.19	\$90.28	\$151.00	\$128.35	\$47.19	\$481.31	\$1,406.18
Reggie Tree - #####	1	Apprentice Carpenter 1st 6 mo. at 40%							40.00	\$32.72	\$1,308.80	\$85.18	\$90.50	\$26.62	\$307.71	\$737.01
Roy Wrench - #####	5	Plumber							20.00	\$67.88	\$1,357.60	\$163.46	\$118.51	\$51.08	\$480.16	\$1,563.04
Roy Wrench - #####	5	Stearnfitter							20.00	\$69.13	\$1,382.60	\$163.46	\$118.51	\$51.08	\$480.16	\$1,563.04
Bart Turner - #####	1	Power Equipment Rotary Drill Group 4							24.00	\$60.80	\$1,459.20	\$115.14	\$122.33	\$35.98	\$415.93	\$1,023.27

While completion of Form WH-347 is required for all federal contractors, it is not required for non-federal contractors. Contractors who are required to file Form WH-347 should file it weekly with respect to the wages paid each employee during the preceding week. U.S. Department of Labor (DOL) regulations at 29 C.F.R. § 5.5(g)(3)(ii) require contractors to file Form WH-347 for each pay period. Contractors who are not required to file Form WH-347 should file it annually. Contractors who are required to file Form WH-347 should file it with the Federal contracting agencies receiving this information to determine if employees have received legally required wages and fringe benefits.

**Burden Statement**  
 We estimate that it will take approximately 15 minutes to search existing data sources, gathering and maintaining the data needed, and completing and reviewing the collection of information. If you have any comments regarding this burden estimate or any aspect of this collection of information, including suggestions for reducing this burden, send them to the Administrator, Wage and Hour Division, ESA, U.S. Department of Labor, Room S3502, 200 Constitution Avenue, N.W., Washington, D.C. 20210

(over)

Fringe benefits are not paid as cash to Bart Turner: explanation is included under "(c) exceptions" on signatory page.

Date 04/28/2010  
 I, Tiffany Payer Payroll Supervisor  
 (Name of Signatory Party) (Title)  
 do hereby state:

(1) That I pay or supervise the payment of the persons employed by  
Sample Construction Company on the  
 (Contractor or Subcontractor)  
Robin Street Apartments, Delafield WA; that during the payroll period commencing on the  
 (Building or Work)  
 18 day of 4 2010 and ending the 24 day of 4 2010  
 all persons employed on said project have been paid the full weekly wages earned, that no rebates have  
 been or will be made either directly or indirectly to or on behalf of said  
Sample Construction Company  
 (Contractor or Subcontractor) from the full

weekly wages earned by any person and that no deductions have been made either directly or indirectly  
 from the full wages earned by any person, other than permissible deductions as defined in Regulations, Part  
 3 (29 C.F.R. Subtitle A), issued by the Secretary of Labor under the Copeland Act, as amended (48 Stat. 948,  
 63 Stat. 108, 72 Stat. 957; 40 U.S.C. § 3145), and described below:

Alex Driver - #### - other deductions - \$85 for child support

Explanation of "other"

(2) That any payrolls otherwise under this contract required to be submitted for the above period are  
 correct and complete; that the wage rates for laborers or mechanics contained therein are not less than the  
 applicable wage rates contained in any wage determination incorporated into the contract; that the  
 classifications set forth therein for each laborer or mechanic conform with the work he performed.

(3) That any apprentices employed in the above period are duly registered in a bona fide  
 apprenticeship program registered with a State apprenticeship agency recognized by the Bureau of  
 Apprenticeship and Training, United States Department of Labor, or if no such recognized agency exists in a  
 State, are registered with the Bureau of Apprenticeship and Training, United States Department of Labor.

(4) That:  
 (a) WHERE FRINGE BENEFITS ARE PAID TO APPROVED PLANS, FUNDS, OR PROGRAMS

— in addition to the basic hourly wage rates paid to each laborer or mechanic listed in  
 the above referenced payroll, payments of fringe benefits as listed in the contract  
 have been or will be made to appropriate programs for the benefit of such  
 employees, except as noted in section 4(c) below.

(b) WHERE FRINGE BENEFITS ARE PAID IN CASH

— Each laborer or mechanic listed in the above referenced payroll has been paid,  
 as indicated on the payroll, an amount not less than the sum of the applicable  
 basic hourly wage rate plus the amount of the required fringe benefits as listed  
 in the contract, except as noted in section 4(c) below.

(c) EXCEPTIONS

EXCEPTION (GRAPH)	EXPLANATION
Power Equipment Rotary Drill Group 4	paid directly to plan: health & dental at \$12.50 per hour and Pension at \$6.25 per hour
Explanation of exception to fringe benefits	

REMARKS:

NAME AND TITLE Robert Sample, Owner	SIGNATURE
THE WILLFUL FALSIFICATION OF ANY OF THE ABOVE STATEMENTS MAY SUBJECT THE CONTRACTOR OR SUBCONTRACTOR TO CIVIL OR CRIMINAL PROSECUTION. SEE SECTION 1001 OF TITLE 19 AND SECTION 231 OF TITLE 31 OF THE UNITED STATES CODE.	

# CONTRACTOR FRINGE BENEFIT STATEMENT

Contract # /Project Name:	Contract Location:	Today's Date:
Contractor / Subcontractor Name:		Business Address:

In order that the proper Fringe Benefit rates can be verified when checking payrolls on the above contract, the hourly rates for fringe benefits, subsistence and/or travel allowance payment made for employees by the employer on the various classes of work are tabulated below. **Please Include Apprentice Rates.**

	Classification:	Effective Date:	Subsistence or Travel Pay: \$ _____
EMPLOYER PAID FRINGE BENEFITS	Health & Welfare \$ _____ hr	Paid To: Name of Plan/Fund/Program: _____ Address: _____	_____
	Pension \$ _____ hr	Paid To: Name of Plan/Fund/Program: _____ Address: _____	_____
	Vacation/Holiday \$ _____ hr	Paid To: Name of Plan/Fund/Program: _____ Address: _____	_____
	Training \$ _____ hr	Paid To: Name of Plan/Fund/Program: _____ Address: _____	_____
	Other \$ _____ hr	Paid To: Name of Plan/Fund/Program: _____ Address: _____	_____

	Classification:	Effective Date:	Subsistence or Travel Pay: \$ _____
EMPLOYER PAID FRINGE BENEFITS	Health & Welfare \$ _____ hr	Paid To: Name of Plan/Fund/Program: _____ Address: _____	_____
	Pension \$ _____ hr	Paid To: Name of Plan/Fund/Program: _____ Address: _____	_____
	Vacation/Holiday \$ _____ hr	Paid To: Name of Plan/Fund/Program: _____ Address: _____	_____
	Training \$ _____ hr	Paid To: Name of Plan/Fund/Program: _____ Address: _____	_____
	Other \$ _____ hr	Paid To: Name of Plan/Fund/Program: _____ Address: _____	_____

Supplemental statements must be submitted during the progress of the work should there be an increase or change in rates. Use additional sheets as necessary. (Attach a copy of your most recent premium transmittal (including copy of check submitted) into each of the above plans/funds/programs or a letter from the above plans/funds/programs reflecting current payment status).

I certify under penalty of perjury that fringe benefits are paid to the approved plans, funds or programs as listed above.

Name and Title	Signature and Date (Wet Signature Required)
----------------	---



# PREVAILING WAGE NOTIFICATION TO EMPLOYEE

Project Name:		Job Number:	
Contractor:			
Project Location:			
Jobsite posting of prevailing wage rates located:			
<b>Prevailing Wage Coordinator</b>		<b>Employee</b>	
Name:		Name:	
Street:		Street:	
City:		City:	
State / Zip:		State / Zip:	
Phone:		Phone:	
<p>You will be performing work on this project that falls under these classifications. You will be paid the appropriate rate for the type of work you are performing.</p>			
<b>Classification</b>	<b>Prevailing Wage Rate Total Package</b>	<b>Minus Your Fringe Benefits</b>	<b>Your Hourly Base Rate</b>
Hourly fringe benefits paid on your behalf by this company.			
<b>Fringe</b>	<b>Amount</b>	<b>Fringe</b>	<b>Amount</b>
Health Insurance		Vacation	
Life Insurance		Holiday	
Pension		Sick Pay	
Bonus		Training	
Other		<b>TOTAL HOURLY FRINGES</b>	
Contractor's Signature:		Date:	
Employee's Signature:		Date:	

"General Decision Number: OH20240001 08/23/2024

Superseded General Decision Number: OH20230001

State: Ohio

Construction Types: Heavy and Highway

Counties: Ohio Statewide.

Heavy and Highway Construction Projects

Note: Contracts subject to the Davis-Bacon Act are generally required to pay at least the applicable minimum wage rate required under Executive Order 14026 or Executive Order 13658. Please note that these Executive Orders apply to covered contracts entered into by the federal government that are subject to the Davis-Bacon Act itself, but do not apply to contracts subject only to the Davis-Bacon Related Acts, including those set forth at 29 CFR 5.1(a)(1).

<p>If the contract is entered into on or after January 30, 2022, or the contract is renewed or extended (e.g., an option is exercised) on or after January 30, 2022:</p>	<p>. Executive Order 14026 generally applies to the contract.                  . The contractor must pay all covered workers at least \$17.20 per hour (or the applicable wage rate listed on this wage determination, if it is higher) for all hours spent performing on the contract in 2024.</p>
<p>If the contract was awarded on or between January 1, 2015 and January 29, 2022, and the contract is not renewed or extended on or after January 30, 2022:</p>	<p>. Executive Order 13658 generally applies to the contract.                  . The contractor must pay all covered workers at least \$12.90 per hour (or the applicable wage rate listed on this wage determination, if it is higher) for all hours spent performing on that contract in 2024.</p>

The applicable Executive Order minimum wage rate will be adjusted annually. If this contract is covered by one of the Executive Orders and a classification considered necessary for performance of work on the contract does not appear on this wage determination, the contractor must still submit a conformance request.

Additional information on contractor requirements and worker protections under the Executive Orders is available at <http://www.dol.gov/whd/govcontracts>.

Modification Number	Publication Date
0	01/05/2024
1	01/26/2024
2	03/08/2024
3	04/05/2024
4	07/05/2024
5	07/26/2024
6	08/23/2024

BROH0001-001 06/01/2023

DEFIANCE, FULTON (Excluding Fulton, Amboy & Swan Creek Townships), HENRY (Excluding Monroe, Bartlow, Liberty, Washington, Richfield, Marion, Damascus & Townships & that part of Harrison Township outside corporate limits of city of Napoleon), PAULDING, PUTNAM and WILLIAMS COUNTIES

	Rates	Fringes
Bricklayer, Stonemason.....	\$ 32.40	19.30

-----  
BROH0001-004 06/01/2023

	Rates	Fringes
CEMENT MASON/CONCRETE FINISHER...	\$ 32.40	19.30

-----  
BROH0003-002 06/01/2023

FULTON (Townships of Amboy, Swan Creek & Fulton), HENRY (Townships of Washington, Damascus, Richfield, Bartlow, Liberty, Harrison, Monroe, & Marion), LUCAS and WOOD (Townships of Perrysburg, Ross, Lake, Troy, Freedom, Montgomery, Webster, Center, Portage, Middleton, Plain, Liberty, Henry, Washington, Weston, Milton, Jackson & Grand Rapids) COUNTIES

	Rates	Fringes
Bricklayer, Stonemason.....	\$ 32.40	19.30

-----  
BROH0005-003 06/01/2020

CUYAHOGA, LORAIN & MEDINA (Hinckley, Granger, Brunswick, Liverpool, Montville, York, Homer, Harrisville, Chatham, Litchfield & Spencer Townships and the city of Medina)

	Rates	Fringes
BRICKLAYER		
BRICKLAYERS; CAULKERS;		
CLEANERS; POINTERS; &		
STONEMASONS.....	\$ 36.64	17.13
SANDBLASTERS.....	\$ 36.39	17.13
SEWER BRICKLAYERS & STACK		
BUILDERS.....	\$ 36.64	17.13
SWING SCAFFOLDS.....	\$ 37.14	17.13

-----  
BROH0006-005 06/01/2023

CARROLL, COLUMBIANA (Knox, Butler, West & Hanover Townships), STARK & TUSCARAWAS

	Rates	Fringes
Bricklayer, Stonemason.....	\$ 32.40	19.30

-----  
BROH0007-002 06/01/2023

LAWRENCE

	Rates	Fringes
Bricklayer, Stonemason.....	\$ 32.40	19.30

BROH0007-005 06/01/2023

PORTAGE & SUMMIT

	Rates	Fringes
BRICKLAYER.....	\$ 32.40	19.30

-----  
BROH0007-010 06/01/2023

PORTAGE & SUMMIT

	Rates	Fringes
MASON - STONE.....	\$ 32.40	19.30

-----  
BROH0008-001 06/01/2023

COLUMBIANA (Salem, Perry, Fairfield, Center, Elk Run, Middleton, & Unity Townships and the city of New Waterford), MAHONING & TRUMBULL

	Rates	Fringes
BRICKLAYER.....	\$ 32.40	19.30

-----  
BROH0009-002 06/01/2023

BELMONT & MONROE COUNTIES and the Townships of Warren & Mt. Pleasant and the Village of Dillonvale in JEFFERSON COUNTY

	Rates	Fringes
Bricklayer, Stonemason.....	\$ 32.40	19.30
Refractory.....	\$ 31.45	19.01

-----  
BROH0010-002 06/01/2023

COLUMBIANA (St. Clair, Madison, Wayne, Franklin, Washington, Yellow Creek & Liverpool Townships) & JEFFERSON (Brush Creek & Saline Townships)

	Rates	Fringes
Bricklayer, Stonemason.....	\$ 32.40	19.30

-----  
BROH0014-002 06/01/2023

HARRISON & JEFFERSON (Except Mt. Pleasant, Warren, Brush Creek, Saline & Salineville Townships & the Village of Dillonvale)

	Rates	Fringes
Bricklayer, Stonemason.....	\$ 32.40	19.30

-----  
BROH0016-002 06/01/2023

ASHTABULA, GEAUGA, and LAKE COUNTIES

	Rates	Fringes
Bricklayer, Stonemason.....	\$ 32.40	19.30

-----  
BROH0018-002 06/01/2023

BROWN, BUTLER, CLERMONT, HAMILTON, PREBLE (Gasper, Dixon, Israel, Lanier, Somers & Gratis Townships) & WARREN COUNTIES:

	Rates	Fringes
Bricklayer, Stonemason.....	\$ 32.40	19.30

-----  
BROH0022-004 06/01/2023

CHAMPAIGN, CLARK, CLINTON, DARKE, GREENE, HIGHLAND, LOGAN, MIAMI, MONTGOMERY, PREBLE (Jackson, Monroe, Harrison, Twin, Jefferson & Washington Townships) and SHELBY COUNTIES

	Rates	Fringes
Bricklayer, Stonemason.....	\$ 32.40	19.30

-----  
BROH0032-001 06/01/2023

GALLIA & MEIGS

	Rates	Fringes
Bricklayer, Stonemason.....	\$ 32.40	19.30

-----  
BROH0035-002 06/01/2023

ALLEN, AUGLAIZE, MERCER and VAN WERT COUNTIES

	Rates	Fringes
Bricklayer, Stonemason.....	\$ 32.40	19.30

-----  
BROH0039-002 06/01/2023

ADAMS & SCIOTO

	Rates	Fringes
Bricklayer, Stonemason.....	\$ 32.40	19.30

-----  
BROH0040-003 06/01/2023

ASHLAND, CRAWFORD, HARDIN, HOLMES, MARION, MORROW, RICHLAND, WAYNE and WYANDOT (Except Crawford, Ridge, Richland & Tymochtee Townships) COUNTIES

	Rates	Fringes
Bricklayer, Stonemason.....	\$ 32.40	19.30

-----  
FOOTNOTE: Layout Man and Sawman rate: \$1.00 per hour above journeyman rate.  
Free standing stack work ground level to top of stack;  
Sandblasting and laying of carbon masonry material in swing stage and/or scaffold; Ramming and spading of plastics and gunniting: \$1.50 per hour above journeyman rate.  
""Hot"" work: \$2.50 above journeyman rate.

-----  
BROH0044-002 06/01/2023

	Rates	Fringes
Bricklayer, Stonemason COSHOCOTON, FAIRFIELD,		

GUERNSEY, HOCKING, KNOX,  
KICKING, MORGAN,  
MUSKINGUM, NOBLE (Beaver,  
Buffalo, Seneca & Wayne  
Townships) & PERRY  
COUNTIES:.....\$ 32.40

19.30

-----  
BROH0045-002 06/01/2023

FAYETTE, JACKSON, PIKE, ROSS and VINTON COUNTIES

Rates Fringes

Bricklayer, Stonemason.....\$ 35.39 17.47

-----  
BROH0046-002 06/01/2023

ERIE, HANCOCK, HURON, OTTAWA, SANDUSKY, SENECA, WOOD (Perry &  
Bloom Townships) and WYANDOT (Tymochtee, Crawford, Ridge &  
Richland Townships) COUNTIES & the Islands of Lake Erie north  
of Sandusky

Rates Fringes

Bricklayer, Stonemason.....\$ 32.40 19.30

FOOTNOTE: Layout Man and Sawman rate: \$1.00 per hour above  
journeyman rate.

Free standing stack work ground level to top of stack;  
Sandblasting and laying of carbon masonry material in swing  
stage and/or scaffold; Ramming and spading of plastics and  
gunniting: \$1.50 per hour above journeyman rate.

""Hot"" work: \$2.50 above journeyman rate.

-----  
BROH0052-001 06/01/2023

ATHENS COUNTY

Rates Fringes

Bricklayer, Stonemason.....\$ 32.40 19.30

-----  
BROH0052-003 06/01/2023

NOBLE (Brookfield, Noble, Center, Sharon, Olive, Enoch, Stock,  
Jackson, Jefferson & Elk Townships) and WASHINGTON COUNTIES

Rates Fringes

Bricklayer, Stonemason.....\$ 32.40 19.30

-----  
BROH0055-003 06/01/2023

DELAWARE, FRANKLIN, MADISON, PICKAWAY and UNION COUNTIES

Rates Fringes

Bricklayer, Stonemason.....\$ 32.40 19.30

-----  
CARP0003-004 05/01/2017

MAHONING & TRUMBULL

Rates Fringes

CARPENTER.....\$ 26.20 17.42

-----  
CARP0069-003 05/01/2017

CARROLL, STARK, TUSCARAWAS & WAYNE

	Rates	Fringes
CARPENTER.....	\$ 25.98	15.98

-----  
CARP0069-006 05/01/2017

COSHOCTON, HOLMES, KNOX & MORROW

	Rates	Fringes
CARPENTER.....	\$ 24.04	15.29

-----  
CARP0171-002 05/01/2024

BELMONT, COLUMBIANA, HARRISON, JEFFERSON & MONROE

	Rates	Fringes
CARPENTER.....	\$ 31.82	25.11

-----  
CARP0200-002 05/01/2024

ADAMS, ATHENS, DELAWARE, FAIRFIELD, FAYETTE, FRANKLIN, GALLIA,  
GUERNSEY, HIGHLAND, HOCKING, JACKSON, LAWRENCE, LICKING,  
MADISON, MARION, MEIGS, MORGAN, MUSKINGUM, NOBLE, PERRY,  
PICKAWAY, PIKE, ROSS, SCIOTO, UNION, VINTON and WASHINGTON  
COUNTIES

	Rates	Fringes
CARPENTER.....	\$ 33.15	22.43
Diver.....	\$ 39.41	10.40
PILEDRIVERMAN.....	\$ 33.15	22.43

-----  
CARP0248-005 07/01/2008

LUCAS & WOOD

	Rates	Fringes
CARPENTER.....	\$ 27.27	14.58

-----  
CARP0248-008 07/01/2008

	Rates	Fringes
CARPENTER DEFIANCE, FULTON, HANCOCK, HENRY, PAULDING & WILLIAMS COUNTIES.....	\$ 23.71	13.28

-----  
CARP0254-002 05/01/2017

ASHTABULA, CUYAHOGA, GEAUGA & LAKE

	Rates	Fringes
CARPENTER.....	\$ 32.40	16.97

-----  
CARP0372-002 05/01/2024

ALLEN, AUGLAIZE, HARDIN, MERCER, PUTNAM & VAN WERT

	Rates	Fringes
CARPENTER.....	\$ 30.73	25.09
-----		
CARP0639-003 05/01/2017		

MEDINA, PORTAGE & SUMMIT

	Rates	Fringes
CARPENTER.....	\$ 30.42	16.99
-----		
CARP0735-002 05/01/2024		

ASHLAND, ERIE, HURON, LORAIN & RICHLAND

	Rates	Fringes
CARPENTER.....	\$ 33.43	22.31
-----		
CARP1311-001 05/01/2017		

BROWN, BUTLER, CHAMPAIGN, CLARK, CLERMONT, CLINTON, DARKE, GREENE, HAMILTON, LOGAN, MIAMI, MONTGOMERY, PREBLE, SHELBY & WARREN

	Rates	Fringes
Carpenter & Piledrivermen.....	\$ 29.34	15.95
Diver.....	\$ 40.58	9.69
-----		
CARP1393-002 05/01/2024		

CRAWFORD, DEFIANCE, FULTON, HANCOCK, HENRY, LUCAS, OTTAWA, PAULDING, SANDUSKY, SENECA, WILLIAMS & WOOD

	Rates	Fringes
Piledrivermen & Diver's Tender...	\$ 36.84	27.72
-----		
DIVERS - \$250.00 per day		
-----		
CARP1393-003 05/01/2024		

ALLEN, AUGLAIZE, HARDIN, MERCER, PUTNAM, VAN WERT & WYANDOT

	Rates	Fringes
Piledrivermen & Diver's Tender...	\$ 34.68	27.60
-----		
DIVERS - \$250.00 per day		
-----		
CARP1871-006 05/01/2017		

BELMONT, HARRISON, & MONROE

	Rates	Fringes
Diver, Wet.....	\$ 48.11	17.33
Piledrivermen; Diver, Dry.....	\$ 32.07	17.33
-----		
CARP1871-008 05/01/2017		

ASHLAND, ASHTABULA, CUYAHOGA, ERIE, GEAUGA, HURON, LAKE, LORAIN, MEDINA, PORTAGE, RICHLAND & SUMMIT



	Rates	Fringes
Diver, Wet.....	\$ 45.80	18.84
Piledrivermen; Diver, Dry.....	\$ 30.53	18.84

-----  
CARP1871-014 05/01/2017

CARROLL, STARK, TUSCARAWAS & WAYNE

	Rates	Fringes
Diver, Wet.....	\$ 38.34	16.95
Piledrivermen; Diver, Dry.....	\$ 25.56	16.95

-----  
CARP1871-015 05/01/2017

COSHOCTON, HOLMES, KNOX & MORROW

	Rates	Fringes
Diver, Wet.....	\$ 37.34	16.07
Piledrivermen; Diver, Dry.....	\$ 24.89	16.07

-----  
CARP1871-017 05/01/2017

MAHONING & TRUMBULL

	Rates	Fringes
Diver, Wet.....	\$ 40.65	17.62
Piledrivermen; Diver, Dry.....	\$ 27.10	17.62

-----  
CARP2235-012 01/01/2014

COLUMBIANA & JEFFERSON

	Rates	Fringes
PILEDRIVERMAN.....	\$ 31.74	16.41

-----  
CARP2239-001 07/01/2008

CRAWFORD, OTTAWA, SANDUSKY, SENECA & WYANDOT

	Rates	Fringes
CARPENTER.....	\$ 23.71	13.28

-----  
ELEC0008-002 05/29/2023

DEFIANCE, FULTON, HANCOCK, HENRY, LUCAS, OTTAWA, PAULDING,  
PUTNAM, SANDUSKY, SENECA, WILLIAMS & WOOD

	Rates	Fringes
CABLE SPLICER.....	\$ 38.98	18.96
ELECTRICIAN.....	\$ 46.38	4.5%+21.96

-----  
ELEC0032-003 06/01/2024

ALLEN, AUGLAIZE, HARDIN, LOGAN, MERCER, SHELBY, VAN WERT &  
WYANDOT (Crawford, Jackson, Marseilles, Mifflin, Ridgeland,  
Ridge & Salem Townships)

	Rates	Fringes
ELECTRICIAN.....	\$ 35.17	22.92

-----  
\* ELEC0038-002 04/29/2024

CUYAHOGA, GEAUGA (Bainbridge, Chester & Russell Townships) & LORAIN (Columbia Township)

Rates Fringes

ELECTRICIAN  
Excluding Sound & Communications Work.....\$ 45.23 23.88

FOOTNOTES;  
a. 6 Paid Holidays: New Year's Day; Memorial Day; July 4th; Labor Day; Thanksgiving Day; & Christmas Day  
b. 1 week's paid vacation for 1 year's service; 2 weeks' paid vacation for 2 or more years' service

-----  
ELEC0038-008 04/24/2023

CUYAHOGA, GEAUGA (Bainbridge, Chester & Russell Townships) & LORAIN (Columbia Township)

Rates Fringes

Sound & Communication Technician  
Communications Technician...\$ 29.80 13.80  
Installer Technician.....\$ 28.55 13.76

FOOTNOTES;  
a. 6 Paid Holidays: New Year's Day; Memorial Day; July 4th; Labor Day; Thanksgiving Day; & Christmas Day  
b. 1 week's paid vacation for 1 year's service; 2 weeks' paid vacation for 2 or more years' service

-----  
ELEC0064-003 11/27/2023

COLUMBIANA (Butler, Fairfield, Perry, Salem & Unity Townships) MAHONING (Austintown, Beaver, Berlin, Boardman, Canfield, Ellsworth, Coitsville, Goshen, Green, Jackson, Poland, Springfield & Youngstown Townships), & TRUMBULL (Hubbard & Liberty Townships)

Rates Fringes

ELECTRICIAN.....\$ 37.90 20.08

-----  
\* ELEC0071-001 01/01/2024

ASHLAND, CHAMPAIGN, CLARK, COSHOCTON, CRAWFORD, DELAWARE, FAIRFIELD, FAYETTE, FRANKLIN, GUERNSEY, HIGHLAND, HOCKING, JACKSON (Coal, Jackson, Liberty, Milton, Washington & Wellston Townships), KNOX, LICKING, MADISON, MARION, MONROE, MORGAN, MORROW, MUSKINGUM, NOBLE, PERRY, PICKAWAY, PIKE (Beaver, Benton, Jackson, Mifflin, Pebble, Peepee, Perry & Seal Townships), RICHLAND, ROSS, TUSCARAWAS (Auburn, Bucks, Clay, Jefferson, Oxford, Perry, Salem, Rush, Washington & York Townships), UNION, VINTON (Clinton, Eagle, Elk, Harrison, Jackson, Richland & Swan Townships), and WASHINGTON COUNTIES

Rates Fringes

Line Construction		
Equipment Operators.....	\$ 39.11	17.14
Groundmen.....	\$ 25.90	13.97
Linemen & Cable Splicers....	\$ 44.52	18.43

\* ELEC0071-004 01/01/2024

AUGLAIZE, CLINTON, DARKE, GREENE, LOGAN, MERCER, MIAMI, MONTGOMERY, PREBLE, and SHELBY COUNTIES

	Rates	Fringes
Line Construction		
Equipment Operator.....	\$ 39.11	17.14
Groundman.....	\$ 25.90	13.97
Lineman & Cable Splicers....	\$ 44.52	18.43

ELEC0071-005 01/01/2024

ASHTABULA, CUYAHOGA, GEAUGA, LAKE & LORAIN

	Rates	Fringes
LINE CONSTRUCTION: Equipment Operator		
DOT/Traffic Signal & Highway Lighting Projects...	\$ 37.43	26%+7.75
Municipal Power/Transit Projects.....	\$ 47.86	27%+7.65
LINE CONSTRUCTION: Groundman		
DOT/Traffic Signal & Highway Lighting Projects...	\$ 25.63	26%+7.75
Municipal Power/Transit Projects.....	\$ 31.91	27%+7.65
LINE CONSTRUCTION: Linemen/Cable Splicer		
DOT/Traffic Signal & Highway Lighting Projects...	\$ 42.20	26%+7.75
Municipal Power/Transit Projects.....	\$ 53.18	27%+7.65

\* ELEC0071-008 01/01/2024

COLUMBIANA, MAHONING, and TRUMBULL COUNTIES

	Rates	Fringes
Line Construction		
Equipment Operator.....	\$ 39.11	17.14
Groundman.....	\$ 25.90	13.97
Lineman & Cable Splicers....	\$ 44.52	18.43

ELEC0071-010 01/01/2024

	Rates	Fringes
Line Construction		
Equipment Operator.....	\$ 39.11	17.14
Groundman.....	\$ 25.90	13.97
Lineman & Cable Splicers....	\$ 44.52	18.43

\* ELEC0071-013 01/01/2024

BROWN, BUTLER, CLERMONT, HAMILTON, and WARREN COUNTIES

	Rates	Fringes
Line Construction		

Equipment Operator.....	\$ 39.11	17.14
Groundman.....	\$ 25.90	13.97
Lineman & Cable Splicers....	\$ 44.52	18.43

-----  
\* ELEC0071-014 01/01/2024

ADAMS, ATHENS, GALLIA, JACKSON (Bloomfield, Franklin, Hamilton, Lick, Jefferson, Scioto & Madison Townships), LAWRENCE, MEIGS, PIKE (Camp Creek, Marion, Newton, Scioto, Sunfish & Union Townships), SCIOTO & VINTON (Brown, Knox, Madison, Vinton & Wilkesville Townships)

Rates Fringes

Line Construction		
Equipment Operator.....	\$ 39.11	17.14
Groundman.....	\$ 25.90	13.97
Lineman & Cable Splicers....	\$ 44.52	18.43

-----  
ELEC0082-002 12/04/2023

CLINTON, DARKE, GREENE, MIAMI, MONTGOMERY, PREBLE & WARREN (Wayne, Clear Creek & Franklin Townships)

Rates Fringes

ELECTRICIAN.....	\$ 36.00	21.99
------------------	----------	-------

-----  
\* ELEC0082-006 11/28/2022

CLINTON, DARKE, GREENE, MIAMI, MONTGOMERY, PREBLE & WARREN (Wayne, Clear Creek & Franklin Townships)

Rates Fringes

Sound & Communication Technician		
Cable Puller.....	\$ 13.10 **	4.76
Installer/Technician.....	\$ 26.20	13.89

-----  
ELEC0129-003 02/26/2024

LORAIN (Except Columbia Township) & MEDINA (Litchfield & Liverpool Townships)

Rates Fringes

ELECTRICIAN.....	\$ 41.40	18.36
------------------	----------	-------

-----  
ELEC0129-004 02/26/2024

ERIE & HURON (Lyme, Ridgefield, Norwalk, Townsend, Wakeman, Sherman, Peru, Bronson, Hartland, Clarksfield, Norwich, Greenfield, Fairfield, Fitchville & New London Townships)

Rates Fringes

ELECTRICIAN.....	\$ 41.40	18.36
------------------	----------	-------

-----  
\* ELEC0141-003 06/02/2024

BELMONT COUNTY

Rates Fringes

CABLE SPLICER.....	\$ 42.94	27.74
ELECTRICIAN.....	\$ 39.04	27.62

-----  
ELEC0212-003 11/26/2018

BROWN, CLERMONT & HAMILTON

	Rates	Fringes
Sound & Communication Technician.....	\$ 24.35	10.99

-----  
\* ELEC0212-005 06/03/2024

BROWN, CLERMONT, and HAMILTON COUNTIES

	Rates	Fringes
ELECTRICIAN.....	\$ 35.43	22.05

-----  
ELEC0245-001 08/29/2022

ALLEN, HARDIN, VAN WERT & WYANDOT (Crawford, Jackson, Marseilles, Mifflin, Richland, Ridge & Salem Townships)

	Rates	Fringes
Line Construction		
Equipment Operator.....	\$ 32.37	26.5%+7.25
Groundman Truck Driver.....	\$ 19.35	7.00+27.25%
Lineman.....	\$ 44.22	7.00+27.25%

FOOTNOTE: a. Half day's Paid Holiday: The last 4 hours of the workday prior to Christmas or New Year's Day

-----  
ELEC0245-003 01/01/2024

DEFIANCE, FULTON, HANCOCK, HENRY, HURON, LUCAS, OTTAWA, PAULDING, PUTNAM, SANDUSKY, SENECA, WILLIAMS, and WOOD COUNTIES

	Rates	Fringes
Line Construction		
Cable Splicer.....	\$ 52.53	7.75+27%
Groundman/Truck Driver.....	\$ 19.99	7.75+27%
Heli-arc Welding.....	\$ 45.98	7.75+27%
Lineman.....	\$ 45.68	7.75+27%
Operator - Class 1.....	\$ 36.54	7.75+27%
Operator - Class 2.....	\$ 31.98	7.75+27%
Traffic Signal & Lighting Technician.....	\$ 41.11	7.75+27%

FOOTNOTE: a. 6 Observed Holidays: New Year's Day; Memorial Day; Independence Day; Labor Day; Thanksgiving Day; & Christmas Day. Employees who work on a holiday shall be paid at a rate of double their applicable classified straight-time rates for the work performed on such holiday.

-----  
ELEC0245-004 08/28/2023

ERIE COUNTY

Rates Fringes

Line Construction

Cable Splicer.....	\$ 49.14	26.75%+6.75
Cablesplicer.....	\$ 52.76	27%+7.50
Groundman/Truck Driver.....	\$ 20.07	27%+7.50
Lineman.....	\$ 45.88	27%+7.50
Operator - Class 1.....	\$ 36.70	27%+7.50
Operator - Class 2.....	\$ 32.12	27%+7.50

FOOTNOTE: a. 6 Observed Holidays: New Year's Day; Memorial Day; Independence Day; Labor Day; Thanksgiving Day; & Christmas Day. Employees who work on a holiday shall be paid at a rate of double their applicable classified straight-time rates for the work performed on such holiday.

-----  
 ELEC0246-001 10/30/2023

	Rates	Fringes
ELECTRICIAN.....	\$ 42.50	55%+13.88

FOOTNOTE: a. 1 1/2 Paid Holidays: The last scheduled workday prior to Christmas & 4 hours on Good Friday.

-----  
 ELEC0306-005 05/29/2023

MEDINA (Brunswick, Chatham, Granger, Guilford, Harrisville, Hinckley, Homer, Lafayette, Medina, Montville, Sharon, Spencer, Wadsworth, Westfield & York Townships), PORTAGE (Atwater, Aurora, Brimfield, Deerfield, Franklin, Mantua, Randolph, Ravenna, Rootstown, Shalersville, Streetsboro & Suffield Townships), SUMMIT & WAYNE (Baughman, Canaan, Chester, Chippewa, Congress, Green, Milton, & Wayne Townships)

	Rates	Fringes
CABLE SPLICER.....	\$ 36.87	16.56
ELECTRICIAN.....	\$ 40.15	5.25%+20.85

-----  
 ELEC0317-002 05/29/2023

GALLIA & LAWRENCE

	Rates	Fringes
CABLE SPLICER.....	\$ 32.68	18.13
ELECTRICIAN.....	\$ 37.15	28.48

-----  
 ELEC0540-005 01/01/2024

CARROLL (Northern half, including Fox, Harrison, Rose & Washington Townships), COLUMBIANA (Knox Township), HOLMES, MAHONING (Smith Township), STARK, TUSCARAWAS (North of Auburn, Clay, Rush & York Townships), and WAYNE (South of Baughman, Chester, Green & Wayne Townships) COUNTIES

	Rates	Fringes
ELECTRICIAN.....	\$ 36.96	28.18

-----  
 \* ELEC0573-003 05/27/2024

ASHTABULA (Colebrook, Wayne, Williamsfield, Orwell & Windsor Townships), GEAUGA (Auburn, Middlefield, Parkman & Troy Townships), MAHONING (Milton Township), PORTAGE (Charlestown, Edinburg, Freedom, Hiram, Nelson, Palmyra, Paris & Windham

Townships), and TRUMBULL (Except Liberty & Hubbard Townships)

	Rates	Fringes
ELECTRICIAN.....	\$ 40.40	22.20

-----  
ELEC0575-001 05/29/2023

ADAMS, FAYETTE, HIGHLAND, HOCKING, JACKSON (Bloomfield, Franklin, Hamilton, Jefferson, Lick, Madison, Scioto, Coal, Jackson, Liberty, Milton & Washington Townships), PICKAWAY (Deer Creek, Perry, Pickaway, Salt Creek & Wayne Townships), PIKE (Beaver, Benton, Jackson, Mifflin, Pebble, PeePee, Perry, Seal, Camp Creek, Newton, Scioto, Sunfish, Union & Marion Townships), ROSS, SCIOTO & VINTON (Clinton, Eagle, Elk, Harrison, Jackson, Richland & Swan Townships)

	Rates	Fringes
ELECTRICIAN.....	\$ 37.00	22.26

-----  
ELEC0648-001 08/29/2023

BUTLER and WARREN COUNTIES (Deerfield, Hamilton, Harlan, Massie, Salem, Turtle Creek, Union & Washington Townships)

	Rates	Fringes
CABLE SPLICER.....	\$ 30.50	18.23
ELECTRICIAN.....	\$ 34.00	21.98

-----  
\* ELEC0673-004 05/27/2024

ASHTABULA (Excluding Orwell, Colebrook, Williamsfield, Wayne & Windsor Townships), GEAUGA (Burton, Chardon, Claridon, Hambden, Huntsburg, Montville, Munson, Newbury & Thompson Townships) and LAKE COUNTIES

	Rates	Fringes
CABLE SPLICER.....	\$ 33.81	21.47
ELECTRICIAN.....	\$ 39.64	23.86

-----  
ELEC0683-002 05/29/2023

CHAMPAIGN, CLARK, DELAWARE, FAIRFIELD, FRANKLIN, MADISON, PICKAWAY (Circleville, Darby, Harrison, Jackson, Madison, Monroe, Muhlenberg, Scioto, Walnut & Washington Townships), and UNION COUNTIES

	Rates	Fringes
CABLE SPLICER.....	\$ 38.75	24.19
ELECTRICIAN.....	\$ 37.75	24.16

-----  
ELEC0688-003 05/30/2022

ASHLAND, CRAWFORD, HURON (Richmond, New Haven, Ripley & Greenwich Townships), KNOX (Liberty, Clinton, Union, Howard, Monroe, Middleberry, Morris, Wayne, Berlin, Pike, Brown & Jefferson Townships), MARION, MORROW, RICHLAND and WYANDOT (Sycamore, Crane, Eden, Pitt, Antrim & Tymochtee Townships) COUNTIES

	Rates	Fringes
ELECTRICIAN.....	\$ 32.30	21.83

-----  
 ELEC0972-002 06/01/2023

ATHENS, MEIGS, MONROE, MORGAN, NOBLE, VINTON (Brown, Knox, Madison, Vinton & Wilkesville Townships), and WASHINGTON COUNITIES

	Rates	Fringes
CABLE SPLICER.....	\$ 35.70	30.26
ELECTRICIAN.....	\$ 35.45	30.25

-----  
 ELEC1105-001 05/29/2023

COSHOCTON, GUERNSEY, KNOX (Jackson, Clay, Morgan, Miller, Milford, Hilliar, Butler, Harrison, Pleasant & College Townships), LICKING, MUSKINGUM, PERRY, and TUSCARAWAS (Auburn, York, Clay, Jefferson, Rush, Oxford, Washington, Salem, Perry & Bucks Townships) COUNTIES

	Rates	Fringes
ELECTRICIAN.....	\$ 36.45	24.22

-----  
 ENGI0018-003 05/01/2024

ASHTABULA, CUYAHOGA, ERIE, GEauga, LAKE, LORAIN, MEDINA, PORTAGE, and SUMMIT COUNTIES

	Rates	Fringes
POWER EQUIPMENT OPERATOR		
GROUP 1.....	\$ 45.63	16.41
GROUP 2.....	\$ 45.53	16.41
GROUP 3.....	\$ 44.49	16.41
GROUP 4.....	\$ 43.27	16.41
GROUP 5.....	\$ 37.98	16.41
GROUP 6.....	\$ 46.63	16.41
GROUP 7.....	\$ 46.63	16.41

OPERATING ENGINEER CLASSIFICATIONS

GROUP 1 - Air Compressor on Steel Erection; Barrier Moving Machine; Boiler Operator on Compressor or Generator when mounted on a Rig; Cableway; Combination Concrete Mixer & Tower; Concrete Plant (over 4 yd. Capacity); Concrete Pump; Crane (All Types, Including Boom Truck, Cherry Picker); Crane-Compact, Track or Rubber over 4,000 lbs. capacity; Cranes-Self Erecting, Stationary, Track or Truck (All Configurations); Derrick; Dragline; Dredge (Dipper, Clam or Suction); Elevating Grader or Euclid Loader; Floating Equipment (All Types); Gradall; Helicopter Crew (Operator-Hoist or Winch); Hoe (all types); Hoisting Engine on Shaft or Tunnel Work; Hydraulic Gantry (Lifting System); Industrial-Type Tractor; Jet Engine Dryer (D8 or D9) Diesel Tractor; Locomotive (Standard Gauge); Maintenance Operator Class A; Mixer, Paving (Single or Double Drum); Mucking Machine; Multiple Scraper; Piledriving Machine (All Types); Power Shovel; Prentice Loader; Quad 9 (Double Pusher); Rail Tamper (with auto lifting & aligning device); Refrigerating Machine (Freezer Operation); Rotary Drill, on Caisson work; Rough Terrain Fork Lift with Winch/Hoist; Side-Boom;



Slip-Form Paver; Tower Derrick; Tree Shredder; Trench Machine (Over 24" wide); Truck Mounted Concrete Pump; Tug Boat; Tunnel Machine and/or Mining Machine; Wheel Excavator; and Asphalt Plant Engineer (Cleveland District Only).

GROUP 2 - Asphalt Paver; Automatic Subgrader Machine, Self-Propelled (CMI Type); Bobcat Type and/or Skid Steer Loader with Hoe Attachment Greater than 7,000 lbs.; Boring Machine More than 48"; Bulldozer; Endloader; Horizontal Directional Drill (Over 50,000 ft lbs thrust); Hydro Milling Machine; Kolman-type Loader (production type-Dirt); Lead Greaseman; Lighting & Traffic Signal Installation Equipment (includes all groups or classifications); Material Transfer Equipment (Shuttle Buggy) Asphalt; Pettibone-Rail Equipment; Power Grader; Power Scraper; Push Cat; Rotomill (all), Grinders & Planers of All types; Trench Machine (24" wide & under); Vermeer type Concrete Saw; and Maintenance Operators (Portage and Summit Counties Only).

GROUP 3 - A-Frame; Air Compressor on Tunnel Work (low pressure); Asphalt Plant Engineer (Portage and Summit Counties Only); Bobcat-type and/or Skid Steer Loader with or without Attachments; Highway Drills (all types); Locomotive (narrow gauge); Material Hoist/Elevator; Mixer, Concrete (more than one bag capacity); Mixer, one bag capacity (Side Loader); Power Boiler (Over 15 lbs. Pressure) Pump Operator installing & operating Well Points; Pump (4" & over discharge); Roller, Asphalt; Rotovator (lime soil stabilizer); Switch & Tie Tampers (without lifting & aligning device); Utility Operator (Small equipment); Welding Machines; and Railroad Tie Inserter/Remover; Articulating/straight bed end dumps if assigned (minus \$4.00 per hour).

GROUP 4 - Backfiller; Ballast Re-locator; Bars, Joint & Mesh Installing Machine; Batch Plant; Boring Machine Operator (48" or less); Bull Floats; Burlap & Curing Machine; Concrete Plant (capacity 4 yd. & under); Concrete Saw (Multiple); Conveyor (Highway); Crusher; Deckhand; Farm-type Tractor with attachments (highway); Finishing Machine; Fireperson, Floating Equipment (all types); Forklift; Form Trencher; Hydro Hammer expect masonry; Hydro Seeder; Pavement Breaker; Plant Mixer; Post Driver; Post Hole Digger (Power Auger); Power Brush Burner; Power Form Handling Equipment; Road Widening Trencher; Roller (Brick, Grade & Macadam); Self-Propelled Power Spreader; Self-Propelled Power Subgrader; Steam Fireperson; Tractor (Pulling Sheepfoot, Roller or Grader); and Vibratory Compactor with Integral Power.

GROUP 5 - Compressor (Portable, Sewer, Heavy & Highway); Drum Fireperson (Asphalt Plant); Generator; Masonry Fork Lift; Inboard-Outboard Motor Boat Launch; Oil Heater (asphalt plant); Oiler/Helper; Power Driven Heater; Power Sweeper & Scrubber; Pump (under 4" discharge); Signalperson; Tire Repairperson; VAC/ALLS; Cranes - Compact, track or rubber under 4,000 pound capacity; fueling and greasing; and Chainmen.

GROUP 6 - Master Mechanic & Boom from 150 to 180.

GROUP 7 - Boom from 180 and over.

-----  
ENGI0018-004 05/01/2024

ADAMS, ALLEN, ASHLAND, ATHENS, AUGLAIZE, BELMONT, BROWN,

BUTLER, CARROLL, CHAMPAIGN, CLARK, CLERMONT, CLINTON, COSHOCTON, CRAWFORD, DARKE, DEFIANCE, DELAWARE, FAIRFIELD, FAYETTE, FRANKLIN, FULTON, GALLIA, GREENE, GUERNSEY, HAMILTON, HANCOCK, HARDIN, HARRISON, HENRY, HIGHLAND, HOCKING, HOLMES, HURON, JACKSON, JEFFERSON, KNOX, LAWRENCE, LICKING, LOGAN, LUCAS, MADISON, MARION, MEIGS, MERCER, MIAMI, MONROE, MONTGOMERY, MORGAN, MORROW, MUSKINGUM, NOBLE, OTTAWA, PAULDING, PERRY, PICKAWAY, PIKE, PREBLE, PUTNAM, RICHLAND, ROSS, SANDUSKY, SCIOTO, SENECA, SHELBY, STARK, TUSCARAWAS, UNION, VAN WERT, VINTON, WARREN, WASHINGTON, WAYNE, WILLIAMS, WOOD, and YANDOT COUNTIES

	Rates	Fringes
POWER EQUIPMENT OPERATOR		
GROUP 1.....	\$ 44.14	16.41
GROUP 2.....	\$ 44.02	16.41
GROUP 3.....	\$ 42.98	16.41
GROUP 4.....	\$ 41.80	16.41
GROUP 5.....	\$ 36.34	16.41
GROUP 6.....	\$ 45.14	16.41
GROUP 7.....	\$ 45.14	16.41

OPERATING ENGINEER CLASSIFICATIONS

GROUP 1 - Air Compressor on Steel Erection; Barrier Moving Machine; Boiler Operator on Compressor or Generator when mounted on a Rig; Cableway; Combination Concrete Mixer & Tower; Concrete Plant (over 4 yd. Capacity); Concrete Pump; Crane (All Types, Including Boom Truck, Cherry Picker); Crane-Compact, Track or Rubber over 4,000 lbs. capacity; Cranes-Self Erecting, Stationary, Track or Truck (All configurations); Derrick; Dragline; Dredge (Dipper, Clam or Suction); Elevating Grader or Euclid Loader; Floating Equipment (All Types); Gradall; Helicopter Crew (Operator-Hoist or Winch); Hoe (all types); Hoisting Engine on Shaft or Tunnel Work; Hydraulic Gantry (Lifting System); Industrial-Type Tractor; Jet Engine Dryer (D8 or D9) Diesel Tractor; Locomotive (Standard Gauge); Maintenance Operator Class A; Mixer, Paving (Single or Double Drum); Mucking Machine; Multiple Scraper; Piledriving Machine (All Types); Power Shovel; Prentice Loader; Quad 9 (Double Pusher); Rail Tamper (with auto lifting & aligning device); Refrigerating Machine (Freezer Operation); Rotary Drill, on Caisson work; Rough Terrain Fork Lift with Winch/Hoist; Side-Boom; Slip-Form Paver; Tower Derrick; Tree Shredder; Trench Machine (Over 24" wide); Truck Mounted Concrete Pump; Tug Boat; Tunnel Machine and/or Mining Machine; and Wheel Excavator.

GROUP 2 - Asphalt Paver; Automatic Subgrader Machine, Self-Propelled (CMI Type); Bobcat Type and/or Skid Steer Loader with Hoe Attachment Greater than 7,000 lbs.; Boring Machine More than 48"; Bulldozer; Endloader; Hydro Milling Machine; Horizontal Directional Drill (over 50,000 ft. lbs. thrust); Kolman-type Loader (production type-Dirt); Lead Greaseman; Lighting & Traffic Signal Installation Equipment (includes all groups or classifications); Material Transfer Equipment (Shuttle Buggy) Asphalt; Pettibone-Rail Equipment; Power Grader; Power Scraper; Push Cat; Rotomill (all), Grinders & Planers of All types; Trench Machine (24" wide & under); and Vermeer type Concrete Saw.

GROUP 3 - A-Frame; Air Compressor on Tunnel Work (low pressure); Asphalt Plant Engineer; Bobcat-type and/or Skid Steer Loader with or without Attachments; Highway Drills (all types); Locomotive (narrow gauge); Material Hoist/Elevator; Mixer, Concrete (more than one bag

capacity); Mixer, one bag capacity (Side Loader); Power Boiler (Over 15 lbs. Pressure) Pump Operator installing & operating Well Points; Pump (4" & over discharge); Railroad Tie Inserter/Remover; Roller, Asphalt; Rotovator (lime soil stabilizer); Switch & Tie Tampers (without lifting & aligning device); Utility Operator (Small equipment); and Welding Machines; Articulating/straight bed end dumps if assigned (minus \$4.00 per hour.

GROUP 4 - Backfiller; Ballast Re-locator; Bars, Joint & Mesh Installing Machine; Batch Plant; Boring Machine Operator (48" or less); Bull Floats; Burlap & Curing Machine; Concrete Plant (capacity 4 yd. & under); Concrete Saw (Multiple); Conveyor (Highway); Crusher; Deckhand; Farm-type Tractor with attachments (highway); Finishing Machine; Fireperson, Floating Equipment (all types); Fork Lift; Form Trencher; Hydro Hammer expect masonry; Hydro Seeder; Pavement Breaker; Plant Mixer; Post Driver; Post Hole Digger (Power Auger); Power Brush Burner; Power Form Handling Equipment; Road Widening Trencher; Roller (Brick, Grade & Macadam); Self-Propelled Power Spreader; Self-Propelled Power Subgrader; Steam Fireperson; Tractor (Pulling Sheepfoot, Roller or Grader); and Vibratory Compactor with Integral Power.

GROUP 5 - Compressor (Portable, Sewer, Heavy & Highway); Drum Fireperson (Asphalt Plant); Generator; Masonary Forklift; Inboard-Outboard Motor Boat Launch; Oil Heater (asphalt plant); Oiler/Helper; Power Driven Heater; Power Sweeper & Scrubber; Pump (under 4" discharge); Signalperson; Tire Repairperson; VAC/ALLS; Cranes - Compact, track or rubber under 4,000 pound capacity; fueling and greasing; and Chainmen.

GROUP 6 - Master Mechanic & Boom from 150 to 180.

GROUP 7 - Boom from 180 and over.

-----  
ENGI0066-023 06/01/2023

COLUMBIANA, MAHONING & TRUMBULL COUNTIES

	Rates	Fringes
POWER EQUIPMENT OPERATOR		
ASBESTOS; HAZARDOUS/TOXIC WASTE PROJECTS		
GROUP 1 - A & B.....	\$ 44.63	24.30
ASBESTOS; HAZARDOUS/TOXIC WASTE PROJECTS		
GROUP 2 - A & B.....	\$ 44.30	24.30
ASBESTOS; HAZARDOUS/TOXIC WASTE PROJECTS		
GROUP 3 - A & B.....	\$ 38.47	24.30
ASBESTOS; HAZARDOUS/TOXIC WASTE PROJECTS		
GROUP 4 - A & B.....	\$ 34.52	24.30
ASBESTOS; HAZARDOUS/TOXIC WASTE PROJECTS		
GROUP 5 - A & B.....	\$ 31.13	24.30
HAZARDOUS/TOXIC WASTE PROJECTS		
GROUP 1 - C & D.....	\$ 40.91	24.30
HAZARDOUS/TOXIC WASTE PROJECTS		
GROUP 2 - C & D.....	\$ 40.61	24.30
HAZARDOUS/TOXIC WASTE PROJECTS		

GROUP 3 - C & D.....\$ 35.27	24.30
HAZARDOUS/TOXIC WASTE PROJECTS	
GROUP 4 - C & D.....\$ 31.65	24.30
HAZARDOUS/TOXIC WASTE PROJECTS	
GROUP 5 - C & D.....\$ 28.53	24.30
ALL OTHER WORK	
GROUP 1.....\$ 37.19	24.30
ALL OTHER WORK	
GROUP 2.....\$ 36.92	24.30
ALL OTHER WORK	
GROUP 3.....\$ 32.06	24.30
ALL OTHER WORK	
GROUP 4.....\$ 28.77	24.30
ALL OTHER WORK	
GROUP 5.....\$ 25.94	24.30

GROUP 1 - Rig, Pile Driver or Caisson Type; & Rig, Pile Hydraulic Unit Attached

GROUP 2 - Asphalt Heater Planer; Backfiller with Drag Attachment; Backhoe; Backhoe with Shear attached; Backhoe-Rear Pivotal Swing; Batch Plant-Central Mix Concrete; Batch Plant, Portable concrete; Berm Builder-Automatic; Boat Derrick; Boat-Tug; Boring Machine Attached to Tractor; Bullclam; Bulldozer; C.M.I. Road Builder & Similar Type; Cable Placer & Layer; Carrier-Straddle; Carryall-Scraper or Scoop; Chicago Boom; Compactor with Blade Attached; Concrete Saw (Vermeer or similar type); Concrete Spreader Finisher; Combination, Bidwell Machine; Crane; Crane-Electric Overhead; Crane-Rough Terrain; Crane-Side Boom; Crane-Truck; Crane-Tower; Derrick-Boom; Derrick-Car; Digger-Wheel (Not trencher or road widener); Double Nine; Drag Line; Dredge; Drill-Kenny or Similar Type; Easy Pour Median Barrier Machine (or similar type); Electromatic; Frankie Pile; Gradall; Grader; Gurry; Self-Propelled; Heavy Equipment Robotics Operator/Mechanic; Hoist-Monorail; Hoist-Stationary & Mobile Tractor; Hoist, 2 or 3 drum; Horizontal Directional Drill Operator; Jackall; Jumbo Machine; Kocal & Kuhlman; Land-Seagoing Vehicle; Loader, Elevating; Loader, Front End; Loader, Skid Steer; Locomotive; Mechanic/Welder; Metro Chip Harvester with Boom; Mucking Machine; Paver-Asphalt Finishing Machine; Paver-Road Concrete; Paver-Slip Form (C.M.I. or similar); Place Crete Machine with Boom; Post Driver (Carrier mounted); Power Driven Hydraulic Pump & Jack (When used in Slip Form or Lift Slab Construction); Pump Crete Machine; Regulator-Ballast; Hydraulic Power Unit not attached to Rig for Pile Drillings; Rigs-Drilling; Roto Mill or similar Full Lane (8' Wide & Over); Roto Mill or similar type (Under 8'); Shovel; Slip Form Curb Machine; Speedwing; Spikemaster; Stonecrusher; Tie Puller & Loader; Tie Tamper; Tractor-Double Boom; Tractor with Attachments; Truck-Boom; Truck-Tire; Trench Machine; Tunnel Machine (Mark 21 Java or similar); & Whirley (or similar type)

GROUP 3 - Asphalt Plant; Bending Machine (Pipeline or similar type); Boring machine, Motor Driven; Chip Harvester without Boom; Cleaning Machine, Pipeline Type; Coating Machine, Pipeline Type; Compactor; Concrete Belt Placer; Concrete Finisher; Concrete Planer or Asphalt; Concrete Spreader; Elevator; Fork Lift (Home building only); Fork lift & Lulls; Fork Lift Walk Behind (Hoisting over 1 buck high); Form Line Machine; Grease Truck operator; Grout Pump; Gunnite Machine; Horizontal Directional Drill Locator; Single Drum Hoist with or without Tower; Huck Bolting Machine; Hydraulic Scaffold (Hoisting building

materials); Paving Breaker (Self-propelled or Ridden); Pipe Dream; Pot Fireperson (Power Agitated); Refrigeration Plant; Road Widener; Roller; Sasgen Derrick; Seeding Machine; Soil Stabilizer (Pump type); Spray Cure Machine, Self-Propelled; Straw Blower Machine; Sub-Grader; Tube Finisher or Broom C.M.I. or similar type; & Tugger Hoist

GROUP 4 - Air Curtain Destructor & Similar Type; Batch Plant-Job Related; Boiler Operator; Compressor; Conveyor; Curb Builder, self-propelled; Drill Wagon; Generator Set; Generator-Steam; Heater-Portable Power; Hydraulic Manipulator Crane; Jack-Hydraulic Power driven; Jack-Hydraulic (Railroad); Ladavator; Minor Machine Operator; Mixer-Concrete; Mulching Machine; Pin Puller; Power Broom; Pulverizer; Pump; Road Finishing Machine (Pull Type); Saw-Concrete-Self-Propelled (Highway Work); Signal Person; Spray Cure Machine-Motor Powered; Stump Cutter; Tractor; Trencher Form; Water Blaster; Steam Jenny; Syphon; Vibrator-Gasoline; & Welding Machine

GROUP 5 - Brakeperson; Fireperson; & Oiler

-----  
IRON0017-002 05/01/2024

ASHTABULA (North of Route 6, starting at the Geauga County Line, proceeding east to State Route 45), CUYAHOGA, ERIE (Eastern 2/3), GEauga, HURON (East of a line drawn from the north border through Monroeville & Willard), LAKE, LORAIN, MEDINA (North of Old Rte. #224), PORTAGE (West of a line from Middlefield to Shalersville to Deerfield), and SUMMIT (North of Old Rte. #224, including city limits of Barberton) COUNTIES

Rates Fringes

IRONWORKER  
Ornamental, Reinforcing, &  
Structural.....\$ 36.83 29.01

-----  
IRON0017-010 05/01/2024

ASHTABULA (Eastern part from Lake Erie on the north to route #322 on the south to include Conneaut, Kingsville, Sheffield, Denmark, Dorset, Cherry Valley, Wayne, Monroe, Pierpont, Richmond, Andover & Williamsfield Townships)

Rates Fringes

IRONWORKER  
Structural, including  
metal building erection &  
Reinforcing.....\$ 36.83 29.01

-----  
IRON0044-001 06/01/2022

ADAMS (Western Part), BROWN, BUTLER (Southern Part), CLERMONT, CLINTON (South of a line drawn from Blanchester to Lynchburg), HAMILTON, HIGHLAND (Excluding eastern one-fifth & portion of county inside lines drawn from Marshall to Lynchburg from the northern county line through E. Monroe to Marshall) and WARREN (South of a line drawn from Blanchester through Morrow to the west county line) COUNTIES

Rates Fringes

IRONWORKER, REINFORCING.....\$ 32.37 22.30

Beyond 30-mile radius of Hamilton County Courthouse..\$ 28.67	21.20
Up to & including 30-mile radius of Hamilton County Courthouse.....\$ 27.60	20.70

-----  
IRON0044-002 06/01/2024

CLINTON (South of a line drawn from Blanchester to Lynchburg),  
HAMILTON, HIGHLAND (Excluding eastern one-fifth & portion of  
county inside lines drawn from Marshall to Lynchburg from the  
northern county line through E. Monroe to Marshall) & WARREN  
(South of a line drawn from Blanchester through Morrow to the  
west county line)

Rates Fringes

IRONWORKER	
Fence Erector.....\$ 33.60	23.00
Ornamental; Structural.....\$ 35.37	23.00

-----  
IRON0055-003 07/01/2024

CRAWFORD (Area Between lines drawn from where Hwy #598 & #30  
meet through N. Liberty to the northern border & from said Hwy  
junction point due west to the border), DEFIANCE (S. of a line  
drawn from where Rte. #66 meets the northern line through  
Independence to the eastern county border), ERIE (Western 1/3),  
FULTON, HANCOCK, HARDIN (North of a line drawn from Maysville  
to a point 4 miles south of the northern line on the eastern  
line), HENRY, HURON (West of a line drawn from the northern  
border through Monroeville & Willard), LUCAS, OTTAWA, PUTNAM  
(East of a line drawn from the northern border down through  
Miller City to where #696 meets the southern border), SANDUSKY,  
SENECA, WILLIAMS (East of a line drawn from Pioneer through  
Stryker to the southern border), WOOD & WYANDOT (North of Rte.  
#30)

Rates Fringes

IRONWORKER	
Fence Erector.....\$ 26.40	24.62
Flat Road Mesh.....\$ 29.77	21.30
Tunnels & Caissons Under Pressure.....\$ 29.77	21.30
All Other Work.....\$ 35.50	29.20

-----  
IRON0147-002 06/01/2024

ALLEN (Northern half), DEFIANCE (Northern part, excluding south  
of a line drawn from where Rte. #66 meets the northern line  
through Independence to the eastern county border), MERCER  
(Northern half), PAULDING, PUTNAM (Western part, excluding east  
of a line drawn from the northern border down through Miller  
City to where #696 meets the southern border), VAN WERT, and  
WILLIAMS (Western part, excluding east of a line drawn from  
Pioneer through Stryker to the southern border) COUNTIES

Rates Fringes

IRONWORKER.....\$ 34.20	26.39
-------------------------	-------

-----  
IRON0172-002 06/01/2024

CHAMPAIGN (Eastern one-third), CLARK (Eastern one-fourth),  
COSHOCOTON (West of a line beginning at the northwestern county

line going through Walhonding & Tunnel Hill to the southern county line), CRAWFORD (South of Rte. #30), DELAWARE, FAIRFIELD, FAYETTE, FRANKLIN, HARDIN (Excluding a line drawn from Roundhead to Maysville), HIGHLAND (Eastern one-fifth), HOCKING, JACKSON (Northern half), KNOX, LICKING, LOGAN (Eastern one-third), MADISON, MARION, MORROW, MUSKINGUM (West of a line starting at Adams Mill going to Adamsville & going from Adamsville through Blue Rock to the southern border), PERRY, PICKAWAY, PIKE (Northern half), ROSS, UNION, VINTON and WYANDOT (South of Rte. #30) COUNTIES

	Rates	Fringes
IRONWORKER.....	\$ 36.77	22.85

-----  
IRON0207-004 06/01/2024

ASHTABULA (Southern part starting at the Geauga County line), COLUMBIANA (E. of a line from Damascus to Highlandtown), MAHONING (N. of Old Route #224), PORTAGE (E. of a line from Middlefield to Shalersville to Deerfield) & TRUMBULL

	Rates	Fringes
IRONWORKER		
Layout; Sheeter.....	\$ 35.83	27.41
Ornamental; Reinforcing;		
Structural.....	\$ 34.83	27.41
Ornamental; Reinforcing....	\$ 28.92	25.61

-----  
IRON0290-002 06/01/2024

ALLEN (Southern half), AUGLAIZE, BUTLER (North of a line drawn from east to the west county line going through Oxford, Darrrtown & Woodsdale), CHAMPAIGN (Excluding east of a line drawn from Catawla to the point where #68 intersects the northern county line), CLARK (Western two-thirds), CLINTON (Excluding south of a line drawn from Blanchester to Lynchburg), DARKE, GREENE, HIGHLAND (Inside lines drawn from Marshall to Lynchburg & from the northern county line through East Monroe to Marshall), LOGAN (West of a line drawn from West Liberty to where the northern county line meets the western county line of Hardin), MERCER (Southern half), MIAMI, MONTGOMERY, PREBLE, SHELBY & WARREN (Excluding south of a line drawn from Blanchester through Morrow to the western county line) COUNTIES

	Rates	Fringes
IRONWORKER.....	\$ 35.39	24.35

-----  
IRON0549-003 12/01/2022

BELMONT, GUERNSEY, HARRISON, JEFFERSON, MONROE & MUSKINGUM (Excluding portion west of a line starting at Adams Mill going to Adamsville and going from Adamsville through Blue Rock to the south border)

	Rates	Fringes
IRONWORKER.....	\$ 35.19	25.66

-----  
IRON0550-004 05/01/2024

ASHLAND, CARROLL, COLUMBIANA (W. of a line from Damascus to

Highlandtown), COSHOCTON (E. of a line beginning at NW Co. line going through Walhonding & Tunnel Hill to the South Co. line), HOLMES, HURON (S. of Old Rte. #224), MAHONING (S. of Old Rte. #224), MEDINA (S. of Old Rte. #224), PORTAGE (S. of Old Rte. #224), RICHLAND, STARK, SUMMIT (S. of Old Rte. #224, Excluding city limits of Barberton), TUSCARAWAS, & WAYNE

	Rates	Fringes
Ironworkers:Structural, Ornamental and Reinforcing.....	\$ 34.70	22.88
-----		
IRON0769-004 06/01/2024		

ADAMS (Eastern Half), GALLIA, JACKSON (Southern Half), LAWRENCE & SCIOTO

	Rates	Fringes
IRONWORKER.....	\$ 37.66	29.24
-----		
IRON0787-003 06/01/2024		

ATHENS, MEIGS, MORGAN, NOBLE, and WASHINGTON COUNTIES

	Rates	Fringes
IRONWORKER.....	\$ 33.00	24.25
-----		
LAB00265-008 05/01/2024		

	Rates	Fringes
LABORER		
ASHTABULA, ERIE, HURON, LORAIN, LUCAS, MAHONING, MEDINA, OTTAWA, PORTAGE, SANDUSKY, STARK, SUMMIT, TRUMBULL & WOOD COUNTIES		
GROUP 1.....	\$ 35.05	13.70
GROUP 2.....	\$ 35.22	13.70
GROUP 3.....	\$ 35.55	13.70
GROUP 4.....	\$ 36.00	13.70
CUYAHOGA AND GEAUGA COUNTIES ONLY: SEWAGE PLANTS, WASTE PLANTS, WATER TREATMENT FACILITIES, PUMPING STATIONS, & ETHANOL PLANTS		
CONSTRUCTION.....	\$ 37.66	13.70
CUYAHOGA, GEAUGA & LAKE COUNTIES		
GROUP 1.....	\$ 36.28	13.70
GROUP 2.....	\$ 36.45	13.70
GROUP 3.....	\$ 36.78	13.70
GROUP 4.....	\$ 37.23	13.70
REMAINING COUNTIES OF OHIO		
GROUP 1.....	\$ 35.52	14.45
GROUP 2.....	\$ 35.69	14.45
GROUP 3.....	\$ 36.02	14.45
GROUP 4.....	\$ 36.47	14.45

LABORER CLASSIFICATIONS

GROUP 1 - Asphalt Laborer; Carpenter Tender; Concrete Curing Applicator; Dump Man (Batch Truck); Guardrail and Fence Installer; Joint Setter; Laborer (Construction); Landscape



Laborer; Mesh Handlers & Placer; Right-of-way Laborer; Riprap Laborer & Grouter; Scaffold Erector; Seal Coating; Surface Treatment or Road Mix Laborer; Sign Installer; Slurry Seal; Utility Man; Bridge Man; Handyman; Waterproofing Laborer; Flagperson; Hazardous Waste (level D); Diver Tender; Zone Person & Traffic Control

GROUP 2 - Asphalt Raker; Concrete Puddler; Kettle Man Pipeline); Machine Driven Tools (Gas, Electric, Air); Mason Tender; Brick Paver; Mortar Mixer; Power Buggy or Power Wheelbarrow; Paint Striper; Sheeting & Shoring Man; Surface Grinder Man; Plastic Fusing Machine Operator; Pug Mill Operator; & Vacuum Devices (wet or dry); Rodding Machine Operator; Diver; Screwman or Paver; Screed Person; Water Blast, Hand Held Wand; Pumps 4" & Under (Gas, Air or Electric) & Hazardous Waste (level C); Air Track and Wagon Drill; Bottom Person; Cofferdam (below 25 ft. deep); Concrete Saw Person; Cutting with Burning Torch; Form Setter; Hand Spiker (Railroad); Pipelayer; Tunnel Laborer (without air) & Caisson; Underground Person (working in Sewer and Waterline, Cleaning, Repairing & Reconditioning); Sandblaster Nozzle Person; & Hazardous Waste (level B)

GROUP 3 - Blaster; Mucker; Powder Person; Top Lander; Wrencher (Mechanical Joints & Utility Pipeline); Yarnier; Hazardous Waste (level A); Concrete Specialist; Concrete Crew in Tunnels (With Air-pressurized - \$1.00 premium); Curb Setter & Cutter; Grade Checker; Utility Pipeline Tapper; Waterline; and Caulker

GROUP 4 - Miner (With Air-pressurized - \$1.00 premium); & Gunite Nozzle Person

TUNNEL LABORER WITH AIR-PRESSURIZED ADD \$1.00 TO BASE RATE

SIGNAL PERSON WILL RECEIVE THE RATE EQUAL TO THE RATE PAID THE LABORER CLASSIFICATION FOR WHICH HE OR SHE IS SIGNALING.

-----

PAIN0006-002 05/01/2023

ASHTABULA, CUYAHOGA, GEAUGA, LAKE, LORAIN, PORTAGE (N. of the East-West Turnpike) & SUMMIT (N. of the East-West Turnpike)

Rates Fringes

PAINTER

COMMERCIAL NEW WORK;		
REMODELING; & RENOVATIONS		
GROUP 1.....	\$ 30.75	18.95
GROUP 2.....	\$ 31.15	18.95
GROUP 3.....	\$ 31.45	18.95
GROUP 4.....	\$ 37.01	18.95
COMMERCIAL REPAINT		
GROUP 1.....	\$ 29.25	18.95
GROUP 2.....	\$ 29.65	18.95
GROUP 3.....	\$ 29.95	18.95

PAINTER CLASSIFICATIONS - COMMERCIAL NEW WORK; REMODELING; & RENOVATIONS

GROUP 1 - Brush; & Roller

GROUP 2 - Sandblasting & Buffing

GROUP 3 - Spray Painting; Closed Steel Above 55 feet; Bridges & Open Structural Steel; Tanks - Water Towers; Bridge Painters; Bridge Riggers; Containment Builders

GROUP 4 - Bridge Blaster

PAINTER CLASSIFICATIONS - COMMERCIAL REPAINT

GROUP 1 - Brush; & Roller

GROUP 2 - Sandblasting & Buffing

GROUP 3 - Spray Painting

-----  
PAIN0007-002 07/01/2024

FULTON, HENRY, LUCAS, OTTAWA (Excluding Allen, Bay, Bono, Catawba Island, Clay Center, Curtice, Danbury, Eagle Beach, Elliston, Elmore, Erie, Fishback, Gem Beach & Genova) & WOOD

Rates Fringes

PAINTER

NEW COMMERCIAL WORK

GROUP 1.....	\$ 31.84	20.79
GROUP 2.....	\$ 32.84	20.79
GROUP 3.....	\$ 32.84	20.79
GROUP 4.....	\$ 32.84	20.79
GROUP 5.....	\$ 32.84	20.79
GROUP 6.....	\$ 32.84	20.79
GROUP 7.....	\$ 32.84	20.79
GROUP 8.....	\$ 32.84	20.79
GROUP 9.....	\$ 32.84	20.79

REPAINT IS 90% OF JR

PAINTER CLASSIFICATIONS

GROUP 1 - Brush; Spray & Sandblasting Pot Tender

GROUP 2 - Refineries & Refinery Tanks; Surfaces 30 ft. or over where material is applied to or labor performed on above ground level (exterior), floor level (interior)

GROUP 3 - Swing Stage & Chair

GROUP 4 - Lead Abatement

GROUP 5 - All Methods of Spray

GROUP 6 - Solvent-Based Catalized Epoxy Materials of 2 or More Component Materials, to include Solvent-Based Conversion Varnish (excluding water based)

GROUP 7 - Spray Solvent Based Material; Sand & Abrasive Blasting

GROUP 8 - Towers; Tanks; Bridges; Stacks Over 30 Feet

GROUP 9 - Epoxy Spray (excluding water based)

-----  
PAIN0012-008 05/01/2019

BUTLER COUNTY

Rates Fringes

PAINTER

GROUP 1.....	\$ 21.95	10.20
--------------	----------	-------

GROUP 2.....	\$ 25.30	10.20
GROUP 3.....	\$ 25.80	10.20
GROUP 4.....	\$ 26.05	10.20
GROUP 5.....	\$ 26.30	10.20

PAINTER CLASSIFICATIONS

GROUP 1: Bridge Equipment Tender; Bridge/Containment Builder

GROUP 2: Brush & Roller

GROUP 3: Spray

GROUP 4: Sandblasting; & Waterblasting

GROUP 5: Elevated Tanks; Steeplejack Work; Bridge; & Lead Abatement

-----  
PAIN0012-010 05/01/2019

BROWN, CLERMONT, CLINTON, HAMILTON & WARREN

Rates Fringes

PAINTER

HEAVY & HIGHWAY BRIDGES- GUARDRAILS-LIGHTPOLES- STRIPING Bridge Equipment Tender and Containment Builder....	\$ 21.95	10.20
Bridges when highest point of clearance is 60 feet or more; & Lead Abatement Projects.....	\$ 26.30	10.20
Brush & Roller.....	\$ 25.30	10.20
Sandblasting & Hopper Tender; Water Blasting....	\$ 26.05	10.20
Spray.....	\$ 25.80	10.20

-----  
PAIN0093-001 12/01/2023

ATHENS, GUERNSEY, HOCKING, MONROE, MORGAN, NOBLE and  
WASHINGTON COUNTIES

Rates Fringes

PAINTER

Bridges; Locks; Dams; Tension Towers; & Energized Substations.....	\$ 35.45	23.69
Power Generating Facilities.	\$ 32.30	23.69

-----  
PAIN0249-002 05/01/2024

CLARK, DARKE, GREENE, MIAMI, MONTGOMERY & PREBLE

Rates Fringes

PAINTER

GROUP 1 - Brush & Roller....	\$ 27.15	13.64
GROUP 2 - Swing, Scaffold Bridges; Structural Steel; Open Acid Tank; High Tension Electrical Equipment; & Hot Pipes.....	\$ 27.15	13.64
GROUP 3 - Spray;		

Sandblast; Steamclean;		
Lead Abatement.....	\$ 27.90	13.64
GROUP 4 - Steeplejack Work..	\$ 28.10	13.64
GROUP 5 - Coal Tar.....	\$ 28.65	13.64
GROUP 6 - Bridge Equipment Tender & or Containment Builder.....	\$ 35.86	13.64
GROUP 7 - Tanks, Stacks & Towers.....	\$ 31.09	13.64
GROUP 8 - Bridge Blaster, Rigger.....	\$ 38.86	13.64

-----  
PAIN0356-002 09/01/2009

KNOX, LICKING, MUSKINGUM, and PERRY

Rates Fringes

PAINTER

Bridge Equipment Tenders and Containment Builders....	\$ 27.93	7.25
Bridges; Blasters; and Riggers.....	\$ 34.60	7.25
Brush and Roller.....	\$ 20.93	7.25
Sandblasting; Steam Cleaning; Waterblasting; and Hazardous Work.....	\$ 25.82	7.25
Spray.....	\$ 21.40	7.25
Structural Steel and Swing Stage.....	\$ 25.42	7.25
Tanks; Stacks; and Towers...\$	28.63	7.25

-----  
PAIN0438-002 12/01/2023

BELMONT, HARRISON and JEFFERSON COUNTIES

Rates Fringes

PAINTER

Bridges, Locks, Dams, Tension Towers & Energized Substations.....	\$ 36.09	19.49
Power Generating Facilities.\$	32.94	19.49

-----  
PAIN0476-001 06/01/2024

COLUMBIANA, MAHONING, and TRUMBULL COUNITIES

Rates Fringes

PAINTER

GROUP 1.....	\$ 28.39	17.14
GROUP 2.....	\$ 35.02	17.14
GROUP 3.....	\$ 28.60	17.14
GROUP 4.....	\$ 28.89	17.14
GROUP 5.....	\$ 29.04	17.14
GROUP 6.....	\$ 29.29	17.14
GROUP 7.....	\$ 30.39	17.14

PAINTER CLASSIFICATIONS:

GROUP 1: Painters, Brush & Roller

GROUP 2: Bridges

GROUP 3: Structural Steel

GROUP 4: Spray, Except Bar Joist/Deck

GROUP 5: Epoxy/Mastic; Spray- Bar Joist/Deck; Working Above 50 Feet; and Swingstages

GROUP 6: Tanks; Sandblasting

GROUP 7: Towers; Stacks

-----  
PAIN0555-002 11/01/2023

ADAMS, HIGHLAND, JACKSON, PIKE & SCIOTO

	Rates	Fringes
PAINTER		
GROUP 1.....	\$ 32.18	20.29
GROUP 2.....	\$ 33.81	20.29
GROUP 3.....	\$ 35.44	20.29
GROUP 4.....	\$ 38.63	20.29

PAINTER CLASSIFICATIONS

GROUP 1 - Containment Builder

GROUP 2 - Brush; Roller; Power Tools, Under 40 feet

GROUP 3 - Sand Blasting; Spray; Steam Cleaning; Pressure Washing; Epoxy & Two Component Materials; Lead Abatement; Hazardous Waste; Toxic Materials; Bulk & Storage Tanks of 25,000 Gallon Capacity or More; Elevated Tanks

GROUP 4 - Stacks; Bridges

-----  
PAIN0639-001 05/01/2011

	Rates	Fringes
Sign Painter & Erector.....	\$ 20.61	3.50+a+b+c

FOOTNOTES: a. 7 Paid Holidays: New Year's Day; Memorial Day; July 4th; Labor Day; Thanksgiving Day; Christmas Day & 1 Floating Day

b. Vacation Pay: After 1 year's service - 5 days' paid vacation; After 2, but less than 10 years' service - 10 days' paid vacation; After 10, but less than 20 years' service - 15 days' paid vacation; After 20 years' service - 20 days' paid vacation

c. Funeral leave up to 3 days maximum paid leave for death of mother, father, brother, sister, spouse, child, mother-in-law, father-in-law, grandparent and inlaw provided employee attends funeral

-----  
PAIN0788-002 06/01/2024

ASHLAND, CRAWFORD, ERIE, HANCOCK, HURON, MARION, MORROW, OTTAWA (Allen, Bay, Bono, Catawba Island, Clay Center, Curtice, Danbury, Eagle Beach, Elliston, Elmore, Erie, Fishback, Gem Beach & Genoa), RICHLAND, SANDUSKY, SENECA & WYANDOT

	Rates	Fringes
PAINTER		
Brush & Roller.....	\$ 29.13	17.52
Structural Steel.....	\$ 30.73	17.52

WINTER REPAINT: Between December 1 to March 31 - 90%JR

\$.50 PER HOUR SHALL BE ADDED TO THE RATE OF PAY FOR THE CLASSIFICATION OF WORK:

While working swingstage, boatswain chair, needle beam and horizontal cable. While operating sprayguns, sandblasting, cobblasting and high pressure waterblasting (4000psi).

\$1.00 PER HOUR SHALL BE ADDED TO THE RATE OF PAY FOR THE CLASSIFICATION OF WORK:

For the application of catalized epoxy, including latex epoxy that is deemed hazardous, lead abatement, or for work or material where special precautions beyond normal work duties must be taken. For working on stacks, tanks, and towers over 40 feet in height.

-----  
PAIN0813-005 12/01/2008

GALLIA, LAWRENCE, MEIGS & VINTON

	Rates	Fringes
PAINTER		
Base Rate.....	\$ 24.83	10.00
Bridges, Locks, Dams & Tension Towers.....	\$ 27.83	10.00

-----  
PAIN0841-001 06/01/2023

MEDINA, PORTAGE (South of and including Ohio Turnpike), and SUMMIT (South of and including Ohio Turnpike) COUNTIES

	Rates	Fringes
Painters:		
GROUP 1.....	\$ 30.18	15.50
GROUP 2.....	\$ 30.83	15.50
GROUP 3.....	\$ 30.93	15.50
GROUP 4.....	\$ 31.03	15.50
GROUP 5.....	\$ 31.43	15.50
GROUP 6.....	\$ 39.20	11.75
GROUP 7.....	\$ 31.68	15.50

PAINTER CLASSIFICATIONS:

GROUP 1 - Brush, Roller & Paperhanger

GROUP 2 - Epoxy Application

GROUP 3 - Swing Scaffold, Bosum Chair, & Window Jack

GROUP 4 - Spray Gun Operator of Any & All Coatings

GROUP 5 - Sandblast, Painting of Standpipes, etc. from Scaffolds, Bridge Work and/or Open Structural Steel, Standpipes and/or Water Towers

GROUP 6 - Public & Commerce Transportation, Steel or Galvanized, Bridges, Tunnels & Related Support Items (concrete)

GROUP 7 - Synthetic Exterior, Drywall Finisher and/or Taper, Drywall Finisher and Follow-up Man Using Automatic Tools

-----  
PAIN0841-002 06/01/2023

CARROLL, COSHOCTON, HOLMES, STARK, TUSCARAWAS & WAYNE

Rates Fringes

PAINTER

Bridges; Towers, Poles & Stacks; Sandblasting Steel; Structural Steel & Metalizing.....	\$ 31.43	15.50
Brush & Roller.....	\$ 30.18	15.50
Spray; Tank Interior & Exterior.....	\$ 31.03	15.50

-----  
PAIN1020-002 04/01/2024

ALLEN, AUGLAIZE, CHAMPAIGN, DEFIANCE, HARDIN, LOGAN, MERCER,  
PAULDING, PUTNAM, SHELBY, VAN WERT, and WILLIAMS COUNTIES

Rates Fringes

PAINTER

Brush & Roller.....	\$ 26.84	17.01
Drywall Finishing & Taping..	\$ 27.59	17.01
Lead Abatement.....	\$ 28.59	17.01
Spray, Sandblasting Pressure Cleaning, & Refinery.....	\$ 27.59	17.01
Swing Stage, Chair, Spiders, & Cherry Pickers...	\$ 27.09	17.01
Wallcoverings.....	\$ 27.59	17.01

All surfaces 40 ft. or over where material is applied to or  
labor performed on, above ground level (exterior), floor  
level (interior) - \$.50 premium

Applying Coal Tar Products - \$1.00 premium

-----  
PAIN1275-002 05/01/2024

DELAWARE, FAIRFIELD, FAYETTE, FRANKLIN, MADISON, PICKAWAY, ROSS  
& UNION

Rates Fringes

PAINTER

Bridges.....	\$ 36.26	14.91
Brush; Roller.....	\$ 30.65	14.91
Sandblasting; Steamcleaning; Waterblasting (3500 PSI or Over)& Hazardous Work.....	\$ 31.35	14.91
Spray.....	\$ 31.15	14.91
Stacks; Tanks; & Towers....	\$ 33.46	14.91
Structural Steel & Swing Stage.....	\$ 29.50	14.91

-----  
PLAS0109-001 06/01/2024

MEDINA, PORTAGE, STARK, and SUMMIT COUNTIES

Rates Fringes

PLASTERER.....	\$ 31.70	23.63
----------------	----------	-------

-----  
PLAS0109-003 06/01/2024

CARROLL, HOLMES, TUSCARAWAS, and WAYNE COUNTIES

	Rates	Fringes
PLASTERER.....	\$ 31.70	23.63

-----  
PLAS0132-002 07/01/2023

BROWN, BUTLER, CLERMONT, HAMILTON, HIGHLAND, WARREN COUNTIES

	Rates	Fringes
PLASTERER.....	\$ 28.40	16.24

-----  
PLAS0404-002 05/01/2018

ASHTABULA, CUYAHOGA, GEAUGA, AND LAKE COUNTIES

	Rates	Fringes
PLASTERER.....	\$ 29.63	17.11

-----  
PLAS0404-003 05/01/2018

LORAIN COUNTY

	Rates	Fringes
PLASTERER.....	\$ 28.86	17.11

-----  
PLAS0526-022 05/01/2018

COLUMBIANA, MAHONING, and TRUMBULL COUNTIES

	Rates	Fringes
PLASTERER.....	\$ 28.86	17.11

-----  
PLAS0526-023 05/01/2018

BELMONT, HARRISON, and JEFFERSON COUNTIES

	Rates	Fringes
PLASTERER.....	\$ 28.21	17.11

-----  
PLAS0886-001 07/01/2024

FULTON, HANCOCK, HENRY, LUCAS, PUTNAM, and WOOD COUNTIES

	Rates	Fringes
PLASTERER.....	\$ 33.73	23.25

-----  
PLAS0886-003 07/01/2024

	Rates	Fringes
PLASTERER.....	\$ 33.73	23.25

-----  
PLAS0886-004 07/01/2024

	Rates	Fringes
PLASTERER.....	\$ 33.73	23.25

-----  
PLUM0042-002 07/01/2024



ASHLAND, CRAWFORD, ERIE, HURON, KNOX, LORAIN, MORROW, RICHLAND & WYANDOT

	Rates	Fringes
Plumber, Pipefitter, Steamfitter.....	\$ 40.62	25.67

-----  
PLUM0050-002 07/01/2024

DEFIANCE, FULTON, HANCOCK, HENRY, LUCAS, OTTAWA, PAULDING, PUTNAM, SANDUSKY, SENECA, WILLIAMS & WOOD

	Rates	Fringes
Plumber, Pipefitter, Steamfitter.....	\$ 49.70	30.76

-----  
PLUM0055-003 05/01/2024

ASHTABULA, CUYAHOGA, GEAUGA, LAKE, MEDINA (N. of Rte. #18 & Smith Road) & SUMMIT (N. of Rte. #303, including the corporate limits of the city of Hudson)

	Rates	Fringes
PLUMBER.....	\$ 42.36	29.90

-----  
PLUM0083-001 07/01/2023

BELMONT & MONROE (North of Rte. #78)

	Rates	Fringes
Plumber and Steamfitter.....	\$ 35.94	37.35

-----  
PLUM0094-002 05/01/2023

CARROLL (Northen Half), STARK, and WAYNE COUNTIES

	Rates	Fringes
PLUMBER/PIPEFITTER.....	\$ 38.03	23.09

-----  
PLUM0120-002 04/29/2024

ASHTABULA, CUYAHOGA, GEAUGA, LAKE, LORAIN (the C.E.I. Power House in Avon Lake), MEDINA (N. of Rte. #18) & SUMMIT (N. of #303)

	Rates	Fringes
PIPEFITTER.....	\$ 47.07	28.15

-----  
PLUM0162-002 06/01/2024

CHAMPAIGN, CLARK, CLINTON, DARKE, FAYETTE, GREENE, MIAMI, MONTGOMERY & PREBLE

	Rates	Fringes
Plumber, Pipefitter, Steamfitter.....	\$ 43.05	27.18

\* PLUM0168-002 06/01/2024

MEIGS, MONROE (South of Rte. #78), MORGAN (South of Rte. #78) & WASHINGTON

	Rates	Fringes
PLUMBER/PIPEFITTER.....	\$ 39.43	37.29
-----		
PLUM0189-002 06/01/2024		

DELAWARE, FAIRFIELD, FRANKLIN, HOCKING, LICKING, MADISON, MARION, PERRY, PICKAWAY, ROSS & UNION

	Rates	Fringes
Plumber, Pipefitter, Steamfitter.....	\$ 43.25	26.94
-----		
PLUM0219-002 06/01/2024		

MEDINA (Rte. #18 from eastern edge of Medina Co., west to eastern corporate limits of the city of Medina, & on the county road from the west corporate limits of Medina running due west to and through community of Risley to the western edge of Medina County - All territory south of this line), PORTAGE, and SUMMIT (S. of Rte. #303) COUNTIES

	Rates	Fringes
Plumber and Steamfitter.....	\$ 45.37	27.64
-----		
PLUM0392-002 06/01/2024		

BROWN, BUTLER, CLERMONT, HAMILTON & WARREN

	Rates	Fringes
PLUMBER/PIPEFITTER.....	\$ 40.65	26.75
-----		
PLUM0396-001 06/01/2024		

COLUMBIANA (Excluding Washington & Yellow Creek Townships & Liverpool Twp. - Secs. 35 & 36 - West of County Road #427), MAHONING and TRUMBULL COUNTIES

	Rates	Fringes
PLUMBER/PIPEFITTER.....	\$ 38.45	28.96
-----		
PLUM0495-002 06/01/2024		

CARROLL (Rose, Monroe, Union, Lee, Orange, Perry & Loudon Townships), COLUMBIANA (Washington & Yellow Creek Townships & Liverpool Township, Secs. 35 & 36, West of County Rd. #427), COSHOCTON, GUERNSEY, HARRISON, HOLMES, JEFFERSON, MORGAN (South to State Rte. #78 & from McConnelville west on State Rte. #37 to the Perry County line), MUSKINGUM, NOBLE, and TUSCARAWAS COUNTIES

	Rates	Fringes
Plumber, Pipefitter, Steamfitter.....	\$ 37.82	36.70

-----  
PLUM0577-002 06/01/2024

ADAMS, ATHENS, GALLIA, HIGHLAND, JACKSON, LAWRENCE, PIKE,  
SCIOTO & VINTON

	Rates	Fringes
Plumber, Pipefitter, Steamfitter.....	\$ 41.65	27.48

-----  
\* PLUM0776-002 07/01/2024

ALLEN, AUGLAIZE, HARDIN, LOGAN, MERCER, SHELBY and VAN WERT  
COUNTIES

	Rates	Fringes
Plumber, Pipefitter, Steamfitter.....	\$ 42.07	29.35

-----  
TEAM0377-003 05/01/2024

STATEWIDE, EXCEPT CUYAHOGA, GEAUGA & LAKE

	Rates	Fringes
TRUCK DRIVER		
GROUP 1.....	\$ 32.54	16.80
GROUP 2.....	\$ 32.96	16.80

TRUCK DRIVER CLASSIFICATIONS

GROUP 1 - Asphalt Distributor; Batch; 4- Wheel Service;  
4-Wheel Dump; Oil Distributor & Tandem

GROUP 2 - Tractor-Trailer Combination: Fuel; Pole Trailer;  
Ready Mix; Semi-Tractor; & Asphalt Oil Spraybar Man When  
Operated From Cab; 5 Axles & Over; Belly Dump; End Dump;  
Articulated Dump; Heavy Duty Equipment; Low Boy; & Truck  
Mechanic

-----  
TEAM0436-002 05/01/2024

CUYAHOGA, GEAUGA & LAKE

	Rates	Fringes
TRUCK DRIVER		
GROUP 1.....	\$ 32.54	16.85
GROUP 2.....	\$ 32.96	16.85

GROUP 1: Straight & Dump, Straight Fuel

GROUP 2: Semi Fuel, Semi Tractor, Euclids, Darts, Tank,  
Asphalt Spreaders, Low Boys, Carry-All, Tourna-Rockers,  
Hi-Lifts, Extra Long Trailers, Semi-Pole Trailers, Double  
Hook-Up Tractor Trailers including Team Track & Railroad  
Siding, Semi-Tractor & Tri-Axle Trailer, Tandem Tractor &  
Tandem Trailer, Tag Along Trailer, Expandable Trailer or  
Towing Requiring Road Permits, Ready-Mix (Agitator or  
Non-Agitator), Bulk Concrete Driver, Dry Batch Truck,  
Articulated End Dump

WELDERS - Receive rate prescribed for craft performing operation to which welding is incidental.

=====  
\*\* Workers in this classification may be entitled to a higher minimum wage under Executive Order 14026 (\$17.20) or 13658 (\$12.90). Please see the Note at the top of the wage determination for more information. Please also note that the minimum wage requirements of Executive Order 14026 are not currently being enforced as to any contract or subcontract to which the states of Texas, Louisiana, or Mississippi, including their agencies, are a party.

Note: Executive Order (EO) 13706, Establishing Paid Sick Leave for Federal Contractors applies to all contracts subject to the Davis-Bacon Act for which the contract is awarded (and any solicitation was issued) on or after January 1, 2017. If this contract is covered by the EO, the contractor must provide employees with 1 hour of paid sick leave for every 30 hours they work, up to 56 hours of paid sick leave each year. Employees must be permitted to use paid sick leave for their own illness, injury or other health-related needs, including preventive care; to assist a family member (or person who is like family to the employee) who is ill, injured, or has other health-related needs, including preventive care; or for reasons resulting from, or to assist a family member (or person who is like family to the employee) who is a victim of, domestic violence, sexual assault, or stalking. Additional information on contractor requirements and worker protections under the EO is available at <https://www.dol.gov/agencies/whd/government-contracts>.

Unlisted classifications needed for work not included within the scope of the classifications listed may be added after award only as provided in the labor standards contract clauses (29CFR 5.5 (a) (1) (iii)).

-----  
The body of each wage determination lists the classification and wage rates that have been found to be prevailing for the cited type(s) of construction in the area covered by the wage determination. The classifications are listed in alphabetical order of ""identifiers"" that indicate whether the particular rate is a union rate (current union negotiated rate for local), a survey rate (weighted average rate) or a union average rate (weighted union average rate).

Union Rate Identifiers

A four letter classification abbreviation identifier enclosed in dotted lines beginning with characters other than ""SU"" or ""UAVG"" denotes that the union classification and rate were prevailing for that classification in the survey. Example: PLUM0198-005 07/01/2014. PLUM is an abbreviation identifier of the union which prevailed in the survey for this classification, which in this example would be Plumbers. 0198 indicates the local union number or district council number where applicable, i.e., Plumbers Local 0198. The next number, 005 in the example, is an internal number used in processing the wage determination. 07/01/2014 is the effective date of the most current negotiated rate, which in this example is July 1, 2014.

Union prevailing wage rates are updated to reflect all rate changes in the collective bargaining agreement (CBA) governing

this classification and rate.

#### Survey Rate Identifiers

Classifications listed under the ""SU"" identifier indicate that no one rate prevailed for this classification in the survey and the published rate is derived by computing a weighted average rate based on all the rates reported in the survey for that classification. As this weighted average rate includes all rates reported in the survey, it may include both union and non-union rates. Example: SULA2012-007 5/13/2014. SU indicates the rates are survey rates based on a weighted average calculation of rates and are not majority rates. LA indicates the State of Louisiana. 2012 is the year of survey on which these classifications and rates are based. The next number, 007 in the example, is an internal number used in producing the wage determination. 5/13/2014 indicates the survey completion date for the classifications and rates under that identifier.

Survey wage rates are not updated and remain in effect until a new survey is conducted.

#### Union Average Rate Identifiers

Classification(s) listed under the UAVG identifier indicate that no single majority rate prevailed for those classifications; however, 100% of the data reported for the classifications was union data. EXAMPLE: UAVG-OH-0010 08/29/2014. UAVG indicates that the rate is a weighted union average rate. OH indicates the state. The next number, 0010 in the example, is an internal number used in producing the wage determination. 08/29/2014 indicates the survey completion date for the classifications and rates under that identifier.

A UAVG rate will be updated once a year, usually in January of each year, to reflect a weighted average of the current negotiated/CBA rate of the union locals from which the rate is based.

#### State Adopted Rate Identifiers

Classifications listed under the ""SA"" identifier indicate that the prevailing wage rate set by a state (or local) government was adopted under 29 C.F.R. 1.3(g)-(h). Example: SAME2023-007 01/03/2024. SA reflects that the rates are state adopted. ME refers to the State of Maine. 2023 is the year during which the state completed the survey on which the listed classifications and rates are based. The next number, 007 in the example, is an internal number used in producing the wage determination. 01/03/2024 reflects the date on which the classifications and rates under the ?SA? identifier took effect under state law in the state from which the rates were adopted.

---

#### WAGE DETERMINATION APPEALS PROCESS

1.) Has there been an initial decision in the matter? This can be:

- \* an existing published wage determination
- \* a survey underlying a wage determination
- \* a Wage and Hour Division letter setting forth a position on a wage determination matter
- \* a conformance (additional classification and rate) ruling

On survey related matters, initial contact, including requests for summaries of surveys, should be with the Wage and Hour National Office because National Office has responsibility for

the Davis-Bacon survey program. If the response from this initial contact is not satisfactory, then the process described in 2.) and 3.) should be followed.

With regard to any other matter not yet ripe for the formal process described here, initial contact should be with the Branch of Construction Wage Determinations. Write to:

Branch of Construction Wage Determinations  
Wage and Hour Division  
U.S. Department of Labor  
200 Constitution Avenue, N.W.  
Washington, DC 20210

2.) If the answer to the question in 1.) is yes, then an interested party (those affected by the action) can request review and reconsideration from the Wage and Hour Administrator (See 29 CFR Part 1.8 and 29 CFR Part 7). Write to:

Wage and Hour Administrator  
U.S. Department of Labor  
200 Constitution Avenue, N.W.  
Washington, DC 20210

The request should be accompanied by a full statement of the interested party's position and by any information (wage payment data, project description, area practice material, etc.) that the requestor considers relevant to the issue.

3.) If the decision of the Administrator is not favorable, an interested party may appeal directly to the Administrative Review Board (formerly the Wage Appeals Board). Write to:

Administrative Review Board  
U.S. Department of Labor  
200 Constitution Avenue, N.W.  
Washington, DC 20210

4.) All decisions by the Administrative Review Board are final.

=====

END OF GENERAL DECISION"

This document has important legal consequences; consultation with an attorney is encouraged with respect to its use or modification. This document should be adapted to the particular circumstances of the contemplated Project and the controlling Laws and Regulations.

# STANDARD GENERAL CONDITIONS OF THE CONSTRUCTION CONTRACT

Prepared by

**ENGINEERS JOINT CONTRACT DOCUMENTS COMMITTEE**

and

Issued and Published Jointly by



AMERICAN COUNCIL OF ENGINEERING COMPANIES

ASSOCIATED GENERAL CONTRACTORS OF AMERICA

AMERICAN SOCIETY OF CIVIL ENGINEERS

PROFESSIONAL ENGINEERS IN PRIVATE PRACTICE  
*A Practice Division of the*  
NATIONAL SOCIETY OF PROFESSIONAL ENGINEERS

Endorsed by



CONSTRUCTION SPECIFICATIONS INSTITUTE

These General Conditions have been prepared for use with the Suggested Forms of Agreement Between Owner and Contractor (EJCDC C-520 or C-525, 2007 Editions). Their provisions are interrelated and a change in one may necessitate a change in the other. Comments concerning their usage are contained in the Narrative Guide to the EJCDC Construction Documents (EJCDC C-001, 2007 Edition). For guidance in the preparation of Supplementary Conditions, see Guide to the Preparation of Supplementary Conditions (EJCDC C-800, 2007 Edition).

Copyright © 2007 National Society of Professional Engineers  
1420 King Street, Alexandria, VA 22314-2794  
(703) 684-2882  
[www.nspe.org](http://www.nspe.org)

American Council of Engineering Companies  
1015 15th Street N.W., Washington, DC 20005  
(202) 347-7474  
[www.acec.org](http://www.acec.org)

American Society of Civil Engineers  
1801 Alexander Bell Drive, Reston, VA 20191-4400  
(800) 548-2723  
[www.asce.org](http://www.asce.org)

Associated General Contractors of America  
2300 Wilson Boulevard, Suite 400, Arlington, VA 22201-3308  
(703) 548-3118  
[www.agc.org](http://www.agc.org)

The copyright for this EJCDC document is owned jointly by the four EJCDC sponsoring organizations and held in trust for their benefit by NSPE.



# STANDARD GENERAL CONDITIONS OF THE CONSTRUCTION CONTRACT

## TABLE OF CONTENTS

	<b>Page</b>
Article 1 – Definitions and Terminology .....	1
1.01 Defined Terms.....	1
1.02 Terminology.....	5
Article 2 – Preliminary Matters .....	6
2.01 Delivery of Bonds and Evidence of Insurance.....	6
2.02 Copies of Documents.....	6
2.03 Commencement of Contract Times; Notice to Proceed.....	6
2.04 Starting the Work.....	7
2.05 Before Starting Construction .....	7
2.06 Preconstruction Conference; Designation of Authorized Representatives .....	7
2.07 Initial Acceptance of Schedules.....	7
Article 3 – Contract Documents: Intent, Amending, Reuse .....	8
3.01 Intent.....	8
3.02 Reference Standards.....	8
3.03 Reporting and Resolving Discrepancies.....	8
3.04 Amending and Supplementing Contract Documents.....	9
3.05 Reuse of Documents .....	10
3.06 Electronic Data.....	10
Article 4 – Availability of Lands; Subsurface and Physical Conditions; Hazardous Environmental Conditions; Reference Points.....	10
4.01 Availability of Lands .....	10
4.02 Subsurface and Physical Conditions .....	11
4.03 Differing Subsurface or Physical Conditions.....	11
4.04 Underground Facilities .....	13
4.05 Reference Points .....	14
4.06 Hazardous Environmental Condition at Site.....	14
Article 5 – Bonds and Insurance .....	16
5.01 Performance, Payment, and Other Bonds .....	16
5.02 Licensed Sureties and Insurers .....	16
5.03 Certificates of Insurance .....	16
5.04 Contractor’s Insurance.....	17
5.05 Owner’s Liability Insurance .....	18
5.06 Property Insurance .....	18
5.07 Waiver of Rights .....	20
5.08 Receipt and Application of Insurance Proceeds.....	21

5.09	Acceptance of Bonds and Insurance; Option to Replace.....	21
5.10	Partial Utilization, Acknowledgment of Property Insurer .....	21
Article 6 – Contractor’s Responsibilities .....		22
6.01	Supervision and Superintendence.....	22
6.02	Labor; Working Hours.....	22
6.03	Services, Materials, and Equipment .....	22
6.04	Progress Schedule .....	23
6.05	Substitutes and “Or-Equals” .....	23
6.06	Concerning Subcontractors, Suppliers, and Others.....	25
6.07	Patent Fees and Royalties .....	27
6.08	Permits.....	27
6.09	Laws and Regulations .....	27
6.10	Taxes .....	28
6.11	Use of Site and Other Areas .....	28
6.12	Record Documents.....	29
6.13	Safety and Protection .....	29
6.14	Safety Representative.....	30
6.15	Hazard Communication Programs .....	30
6.16	Emergencies .....	30
6.17	Shop Drawings and Samples .....	30
6.18	Continuing the Work.....	32
6.19	Contractor’s General Warranty and Guarantee.....	32
6.20	Indemnification .....	33
6.21	Delegation of Professional Design Services .....	34
Article 7 – Other Work at the Site.....		35
7.01	Related Work at Site .....	35
7.02	Coordination.....	35
7.03	Legal Relationships.....	36
Article 8 – Owner’s Responsibilities.....		36
8.01	Communications to Contractor.....	36
8.02	Replacement of Engineer.....	36
8.03	Furnish Data .....	36
8.04	Pay When Due .....	36
8.05	Lands and Easements; Reports and Tests.....	36
8.06	Insurance .....	36
8.07	Change Orders.....	36
8.08	Inspections, Tests, and Approvals .....	37
8.09	Limitations on Owner’s Responsibilities .....	37
8.10	Undisclosed Hazardous Environmental Condition .....	37
8.11	Evidence of Financial Arrangements .....	37
8.12	Compliance with Safety Program.....	37
Article 9 – Engineer’s Status During Construction .....		37
9.01	Owner’s Representative.....	37
9.02	Visits to Site .....	37

9.03	Project Representative .....	38
9.04	Authorized Variations in Work .....	38
9.05	Rejecting Defective Work .....	38
9.06	Shop Drawings, Change Orders and Payments.....	38
9.07	Determinations for Unit Price Work .....	39
9.08	Decisions on Requirements of Contract Documents and Acceptability of Work.....	39
9.09	Limitations on Engineer’s Authority and Responsibilities.....	39
9.10	Compliance with Safety Program.....	40
Article 10 – Changes in the Work; Claims .....		40
10.01	Authorized Changes in the Work .....	40
10.02	Unauthorized Changes in the Work .....	40
10.03	Execution of Change Orders.....	41
10.04	Notification to Surety.....	41
10.05	Claims.....	41
Article 11 – Cost of the Work; Allowances; Unit Price Work.....		42
11.01	Cost of the Work .....	42
11.02	Allowances .....	45
11.03	Unit Price Work .....	45
Article 12 – Change of Contract Price; Change of Contract Times .....		46
12.01	Change of Contract Price.....	46
12.02	Change of Contract Times .....	47
12.03	Delays.....	47
Article 13 – Tests and Inspections; Correction, Removal or Acceptance of Defective Work .....		48
13.01	Notice of Defects .....	48
13.02	Access to Work .....	48
13.03	Tests and Inspections .....	48
13.04	Uncovering Work.....	49
13.05	Owner May Stop the Work.....	50
13.06	Correction or Removal of Defective Work .....	50
13.07	Correction Period.....	50
13.08	Acceptance of Defective Work.....	51
13.09	Owner May Correct Defective Work .....	51
Article 14 – Payments to Contractor and Completion.....		52
14.01	Schedule of Values.....	52
14.02	Progress Payments .....	52
14.03	Contractor’s Warranty of Title .....	55
14.04	Substantial Completion.....	55
14.05	Partial Utilization .....	56
14.06	Final Inspection.....	56
14.07	Final Payment.....	57
14.08	Final Completion Delayed.....	58
14.09	Waiver of Claims .....	58

Article 15 – Suspension of Work and Termination .....	58
15.01 Owner May Suspend Work .....	58
15.02 Owner May Terminate for Cause .....	58
15.03 Owner May Terminate For Convenience.....	60
15.04 Contractor May Stop Work or Terminate .....	60
Article 16 – Dispute Resolution .....	61
16.01 Methods and Procedures.....	61
Article 17 – Miscellaneous .....	61
17.01 Giving Notice .....	61
17.02 Computation of Times .....	61
17.03 Cumulative Remedies .....	62
17.04 Survival of Obligations .....	62
17.05 Controlling Law .....	62
17.06 Headings.....	62

## ARTICLE 1 – DEFINITIONS AND TERMINOLOGY

### 1.01 *Defined Terms*

- A. Wherever used in the Bidding Requirements or Contract Documents and printed with initial capital letters, the terms listed below will have the meanings indicated which are applicable to both the singular and plural thereof. In addition to terms specifically defined, terms with initial capital letters in the Contract Documents include references to identified articles and paragraphs, and the titles of other documents or forms.
1. *Addenda*—Written or graphic instruments issued prior to the opening of Bids which clarify, correct, or change the Bidding Requirements or the proposed Contract Documents.
  2. *Agreement*—The written instrument which is evidence of the agreement between Owner and Contractor covering the Work.
  3. *Application for Payment*—The form acceptable to Engineer which is to be used by Contractor during the course of the Work in requesting progress or final payments and which is to be accompanied by such supporting documentation as is required by the Contract Documents.
  4. *Asbestos*—Any material that contains more than one percent asbestos and is friable or is releasing asbestos fibers into the air above current action levels established by the United States Occupational Safety and Health Administration.
  5. *Bid*—The offer or proposal of a Bidder submitted on the prescribed form setting forth the prices for the Work to be performed.
  6. *Bidder*—The individual or entity who submits a Bid directly to Owner.
  7. *Bidding Documents*—The Bidding Requirements and the proposed Contract Documents (including all Addenda).
  8. *Bidding Requirements*—The advertisement or invitation to bid, Instructions to Bidders, Bid security of acceptable form, if any, and the Bid Form with any supplements.
  9. *Change Order*—A document recommended by Engineer which is signed by Contractor and Owner and authorizes an addition, deletion, or revision in the Work or an adjustment in the Contract Price or the Contract Times, issued on or after the Effective Date of the Agreement.
  10. *Claim*—A demand or assertion by Owner or Contractor seeking an adjustment of Contract Price or Contract Times, or both, or other relief with respect to the terms of the Contract. A demand for money or services by a third party is not a Claim.
  11. *Contract*—The entire and integrated written agreement between the Owner and Contractor concerning the Work. The Contract supersedes prior negotiations, representations, or agreements, whether written or oral.

12. *Contract Documents*—Those items so designated in the Agreement. Only printed or hard copies of the items listed in the Agreement are Contract Documents. Approved Shop Drawings, other Contractor submittals, and the reports and drawings of subsurface and physical conditions are not Contract Documents.
13. *Contract Price*—The moneys payable by Owner to Contractor for completion of the Work in accordance with the Contract Documents as stated in the Agreement (subject to the provisions of Paragraph 11.03 in the case of Unit Price Work).
14. *Contract Times*—The number of days or the dates stated in the Agreement to: (i) achieve Milestones, if any; (ii) achieve Substantial Completion; and (iii) complete the Work so that it is ready for final payment as evidenced by Engineer's written recommendation of final payment.
15. *Contractor*—The individual or entity with whom Owner has entered into the Agreement.
16. *Cost of the Work*—See Paragraph 11.01 for definition.
17. *Drawings*—That part of the Contract Documents prepared or approved by Engineer which graphically shows the scope, extent, and character of the Work to be performed by Contractor. Shop Drawings and other Contractor submittals are not Drawings as so defined.
18. *Effective Date of the Agreement*—The date indicated in the Agreement on which it becomes effective, but if no such date is indicated, it means the date on which the Agreement is signed and delivered by the last of the two parties to sign and deliver.
19. *Engineer*—The individual or entity named as such in the Agreement.
20. *Field Order*—A written order issued by Engineer which requires minor changes in the Work but which does not involve a change in the Contract Price or the Contract Times.
21. *General Requirements*—Sections of Division 1 of the Specifications.
22. *Hazardous Environmental Condition*—The presence at the Site of Asbestos, PCBs, Petroleum, Hazardous Waste, or Radioactive Material in such quantities or circumstances that may present a substantial danger to persons or property exposed thereto.
23. *Hazardous Waste*—The term Hazardous Waste shall have the meaning provided in Section 1004 of the Solid Waste Disposal Act (42 USC Section 6903) as amended from time to time.
24. *Laws and Regulations; Laws or Regulations*—Any and all applicable laws, rules, regulations, ordinances, codes, and orders of any and all governmental bodies, agencies, authorities, and courts having jurisdiction.
25. *Liens*—Charges, security interests, or encumbrances upon Project funds, real property, or personal property.
26. *Milestone*—A principal event specified in the Contract Documents relating to an intermediate completion date or time prior to Substantial Completion of all the Work.

27. *Notice of Award*—The written notice by Owner to the Successful Bidder stating that upon timely compliance by the Successful Bidder with the conditions precedent listed therein, Owner will sign and deliver the Agreement.
28. *Notice to Proceed*—A written notice given by Owner to Contractor fixing the date on which the Contract Times will commence to run and on which Contractor shall start to perform the Work under the Contract Documents.
29. *Owner*—The individual or entity with whom Contractor has entered into the Agreement and for whom the Work is to be performed.
30. *PCBs*—Polychlorinated biphenyls.
31. *Petroleum*—Petroleum, including crude oil or any fraction thereof which is liquid at standard conditions of temperature and pressure (60 degrees Fahrenheit and 14.7 pounds per square inch absolute), such as oil, petroleum, fuel oil, oil sludge, oil refuse, gasoline, kerosene, and oil mixed with other non-Hazardous Waste and crude oils.
32. *Progress Schedule*—A schedule, prepared and maintained by Contractor, describing the sequence and duration of the activities comprising the Contractor's plan to accomplish the Work within the Contract Times.
33. *Project*—The total construction of which the Work to be performed under the Contract Documents may be the whole, or a part.
34. *Project Manual*—The bound documentary information prepared for bidding and constructing the Work. A listing of the contents of the Project Manual, which may be bound in one or more volumes, is contained in the table(s) of contents.
35. *Radioactive Material*—Source, special nuclear, or byproduct material as defined by the Atomic Energy Act of 1954 (42 USC Section 2011 et seq.) as amended from time to time.
36. *Resident Project Representative*—The authorized representative of Engineer who may be assigned to the Site or any part thereof.
37. *Samples*—Physical examples of materials, equipment, or workmanship that are representative of some portion of the Work and which establish the standards by which such portion of the Work will be judged.
38. *Schedule of Submittals*—A schedule, prepared and maintained by Contractor, of required submittals and the time requirements to support scheduled performance of related construction activities.
39. *Schedule of Values*—A schedule, prepared and maintained by Contractor, allocating portions of the Contract Price to various portions of the Work and used as the basis for reviewing Contractor's Applications for Payment.

40. *Shop Drawings*—All drawings, diagrams, illustrations, schedules, and other data or information which are specifically prepared or assembled by or for Contractor and submitted by Contractor to illustrate some portion of the Work.
41. *Site*—Lands or areas indicated in the Contract Documents as being furnished by Owner upon which the Work is to be performed, including rights-of-way and easements for access thereto, and such other lands furnished by Owner which are designated for the use of Contractor.
42. *Specifications*—That part of the Contract Documents consisting of written requirements for materials, equipment, systems, standards and workmanship as applied to the Work, and certain administrative requirements and procedural matters applicable thereto.
43. *Subcontractor*—An individual or entity having a direct contract with Contractor or with any other Subcontractor for the performance of a part of the Work at the Site.
44. *Substantial Completion*—The time at which the Work (or a specified part thereof) has progressed to the point where, in the opinion of Engineer, the Work (or a specified part thereof) is sufficiently complete, in accordance with the Contract Documents, so that the Work (or a specified part thereof) can be utilized for the purposes for which it is intended. The terms “substantially complete” and “substantially completed” as applied to all or part of the Work refer to Substantial Completion thereof.
45. *Successful Bidder*—The Bidder submitting a responsive Bid to whom Owner makes an award.
46. *Supplementary Conditions*—That part of the Contract Documents which amends or supplements these General Conditions.
47. *Supplier*—A manufacturer, fabricator, supplier, distributor, materialman, or vendor having a direct contract with Contractor or with any Subcontractor to furnish materials or equipment to be incorporated in the Work by Contractor or Subcontractor.
48. *Underground Facilities*—All underground pipelines, conduits, ducts, cables, wires, manholes, vaults, tanks, tunnels, or other such facilities or attachments, and any encasements containing such facilities, including those that convey electricity, gases, steam, liquid petroleum products, telephone or other communications, cable television, water, wastewater, storm water, other liquids or chemicals, or traffic or other control systems.
49. *Unit Price Work*—Work to be paid for on the basis of unit prices.
50. *Work*—The entire construction or the various separately identifiable parts thereof required to be provided under the Contract Documents. Work includes and is the result of performing or providing all labor, services, and documentation necessary to produce such construction, and furnishing, installing, and incorporating all materials and equipment into such construction, all as required by the Contract Documents.
51. *Work Change Directive*—A written statement to Contractor issued on or after the Effective Date of the Agreement and signed by Owner and recommended by Engineer ordering an



addition, deletion, or revision in the Work, or responding to differing or unforeseen subsurface or physical conditions under which the Work is to be performed or to emergencies. A Work Change Directive will not change the Contract Price or the Contract Times but is evidence that the parties expect that the change ordered or documented by a Work Change Directive will be incorporated in a subsequently issued Change Order following negotiations by the parties as to its effect, if any, on the Contract Price or Contract Times.

## 1.02 Terminology

A. The words and terms discussed in Paragraph 1.02.B through F are not defined but, when used in the Bidding Requirements or Contract Documents, have the indicated meaning.

### B. *Intent of Certain Terms or Adjectives:*

1. The Contract Documents include the terms “as allowed,” “as approved,” “as ordered,” “as directed” or terms of like effect or import to authorize an exercise of professional judgment by Engineer. In addition, the adjectives “reasonable,” “suitable,” “acceptable,” “proper,” “satisfactory,” or adjectives of like effect or import are used to describe an action or determination of Engineer as to the Work. It is intended that such exercise of professional judgment, action, or determination will be solely to evaluate, in general, the Work for compliance with the information in the Contract Documents and with the design concept of the Project as a functioning whole as shown or indicated in the Contract Documents (unless there is a specific statement indicating otherwise). The use of any such term or adjective is not intended to and shall not be effective to assign to Engineer any duty or authority to supervise or direct the performance of the Work, or any duty or authority to undertake responsibility contrary to the provisions of Paragraph 9.09 or any other provision of the Contract Documents.

### C. *Day:*

1. The word “day” means a calendar day of 24 hours measured from midnight to the next midnight.

### D. *Defective:*

1. The word “defective,” when modifying the word “Work,” refers to Work that is unsatisfactory, faulty, or deficient in that it:
  - a. does not conform to the Contract Documents; or
  - b. does not meet the requirements of any applicable inspection, reference standard, test, or approval referred to in the Contract Documents; or
  - c. has been damaged prior to Engineer’s recommendation of final payment (unless responsibility for the protection thereof has been assumed by Owner at Substantial Completion in accordance with Paragraph 14.04 or 14.05).

### E. *Furnish, Install, Perform, Provide:*

1. The word “furnish,” when used in connection with services, materials, or equipment, shall mean to supply and deliver said services, materials, or equipment to the Site (or some other specified location) ready for use or installation and in usable or operable condition.
  2. The word “install,” when used in connection with services, materials, or equipment, shall mean to put into use or place in final position said services, materials, or equipment complete and ready for intended use.
  3. The words “perform” or “provide,” when used in connection with services, materials, or equipment, shall mean to furnish and install said services, materials, or equipment complete and ready for intended use.
  4. When “furnish,” “install,” “perform,” or “provide” is not used in connection with services, materials, or equipment in a context clearly requiring an obligation of Contractor, “provide” is implied.
- F. Unless stated otherwise in the Contract Documents, words or phrases that have a well-known technical or construction industry or trade meaning are used in the Contract Documents in accordance with such recognized meaning.

## **ARTICLE 2 – PRELIMINARY MATTERS**

### **2.01 *Delivery of Bonds and Evidence of Insurance***

- A. When Contractor delivers the executed counterparts of the Agreement to Owner, Contractor shall also deliver to Owner such bonds as Contractor may be required to furnish.
- B. *Evidence of Insurance:* Before any Work at the Site is started, Contractor and Owner shall each deliver to the other, with copies to each additional insured identified in the Supplementary Conditions, certificates of insurance (and other evidence of insurance which either of them or any additional insured may reasonably request) which Contractor and Owner respectively are required to purchase and maintain in accordance with Article 5.

### **2.02 *Copies of Documents***

- A. Owner shall furnish to Contractor up to ten printed or hard copies of the Drawings and Project Manual. Additional copies will be furnished upon request at the cost of reproduction.

### **2.03 *Commencement of Contract Times; Notice to Proceed***

- A. The Contract Times will commence to run on the thirtieth day after the Effective Date of the Agreement or, if a Notice to Proceed is given, on the day indicated in the Notice to Proceed. A Notice to Proceed may be given at any time within 30 days after the Effective Date of the Agreement. In no event will the Contract Times commence to run later than the sixtieth day after the day of Bid opening or the thirtieth day after the Effective Date of the Agreement, whichever date is earlier.

## 2.04 *Starting the Work*

- A. Contractor shall start to perform the Work on the date when the Contract Times commence to run. No Work shall be done at the Site prior to the date on which the Contract Times commence to run.

## 2.05 *Before Starting Construction*

- A. *Preliminary Schedules:* Within 10 days after the Effective Date of the Agreement (unless otherwise specified in the General Requirements), Contractor shall submit to Engineer for timely review:
  - 1. a preliminary Progress Schedule indicating the times (numbers of days or dates) for starting and completing the various stages of the Work, including any Milestones specified in the Contract Documents;
  - 2. a preliminary Schedule of Submittals; and
  - 3. a preliminary Schedule of Values for all of the Work which includes quantities and prices of items which when added together equal the Contract Price and subdivides the Work into component parts in sufficient detail to serve as the basis for progress payments during performance of the Work. Such prices will include an appropriate amount of overhead and profit applicable to each item of Work.

## 2.06 *Preconstruction Conference; Designation of Authorized Representatives*

- A. Before any Work at the Site is started, a conference attended by Owner, Contractor, Engineer, and others as appropriate will be held to establish a working understanding among the parties as to the Work and to discuss the schedules referred to in Paragraph 2.05.A, procedures for handling Shop Drawings and other submittals, processing Applications for Payment, and maintaining required records.
- B. At this conference Owner and Contractor each shall designate, in writing, a specific individual to act as its authorized representative with respect to the services and responsibilities under the Contract. Such individuals shall have the authority to transmit instructions, receive information, render decisions relative to the Contract, and otherwise act on behalf of each respective party.

## 2.07 *Initial Acceptance of Schedules*

- A. At least 10 days before submission of the first Application for Payment a conference attended by Contractor, Engineer, and others as appropriate will be held to review for acceptability to Engineer as provided below the schedules submitted in accordance with Paragraph 2.05.A. Contractor shall have an additional 10 days to make corrections and adjustments and to complete and resubmit the schedules. No progress payment shall be made to Contractor until acceptable schedules are submitted to Engineer.
  - 1. The Progress Schedule will be acceptable to Engineer if it provides an orderly progression of the Work to completion within the Contract Times. Such acceptance will not impose on Engineer responsibility for the Progress Schedule, for sequencing, scheduling, or progress of

the Work, nor interfere with or relieve Contractor from Contractor's full responsibility therefor.

2. Contractor's Schedule of Submittals will be acceptable to Engineer if it provides a workable arrangement for reviewing and processing the required submittals.
3. Contractor's Schedule of Values will be acceptable to Engineer as to form and substance if it provides a reasonable allocation of the Contract Price to component parts of the Work.

### **ARTICLE 3 – CONTRACT DOCUMENTS: INTENT, AMENDING, REUSE**

#### **3.01 *Intent***

- A. The Contract Documents are complementary; what is required by one is as binding as if required by all.
- B. It is the intent of the Contract Documents to describe a functionally complete project (or part thereof) to be constructed in accordance with the Contract Documents. Any labor, documentation, services, materials, or equipment that reasonably may be inferred from the Contract Documents or from prevailing custom or trade usage as being required to produce the indicated result will be provided whether or not specifically called for, at no additional cost to Owner.
- C. Clarifications and interpretations of the Contract Documents shall be issued by Engineer as provided in Article 9.

#### **3.02 *Reference Standards***

- A. Standards, Specifications, Codes, Laws, and Regulations
  1. Reference to standards, specifications, manuals, or codes of any technical society, organization, or association, or to Laws or Regulations, whether such reference be specific or by implication, shall mean the standard, specification, manual, code, or Laws or Regulations in effect at the time of opening of Bids (or on the Effective Date of the Agreement if there were no Bids), except as may be otherwise specifically stated in the Contract Documents.
  2. No provision of any such standard, specification, manual, or code, or any instruction of a Supplier, shall be effective to change the duties or responsibilities of Owner, Contractor, or Engineer, or any of their subcontractors, consultants, agents, or employees, from those set forth in the Contract Documents. No such provision or instruction shall be effective to assign to Owner, Engineer, or any of their officers, directors, members, partners, employees, agents, consultants, or subcontractors, any duty or authority to supervise or direct the performance of the Work or any duty or authority to undertake responsibility inconsistent with the provisions of the Contract Documents.

#### **3.03 *Reporting and Resolving Discrepancies***

- A. *Reporting Discrepancies:*

1. *Contractor's Review of Contract Documents Before Starting Work:* Before undertaking each part of the Work, Contractor shall carefully study and compare the Contract Documents and check and verify pertinent figures therein and all applicable field measurements. Contractor shall promptly report in writing to Engineer any conflict, error, ambiguity, or discrepancy which Contractor discovers, or has actual knowledge of, and shall obtain a written interpretation or clarification from Engineer before proceeding with any Work affected thereby.
2. *Contractor's Review of Contract Documents During Performance of Work:* If, during the performance of the Work, Contractor discovers any conflict, error, ambiguity, or discrepancy within the Contract Documents, or between the Contract Documents and (a) any applicable Law or Regulation, (b) any standard, specification, manual, or code, or (c) any instruction of any Supplier, then Contractor shall promptly report it to Engineer in writing. Contractor shall not proceed with the Work affected thereby (except in an emergency as required by Paragraph 6.16.A) until an amendment or supplement to the Contract Documents has been issued by one of the methods indicated in Paragraph 3.04.
3. Contractor shall not be liable to Owner or Engineer for failure to report any conflict, error, ambiguity, or discrepancy in the Contract Documents unless Contractor had actual knowledge thereof.

B. *Resolving Discrepancies:*

1. Except as may be otherwise specifically stated in the Contract Documents, the provisions of the Contract Documents shall take precedence in resolving any conflict, error, ambiguity, or discrepancy between the provisions of the Contract Documents and:
  - a. the provisions of any standard, specification, manual, or code, or the instruction of any Supplier (whether or not specifically incorporated by reference in the Contract Documents); or
  - b. the provisions of any Laws or Regulations applicable to the performance of the Work (unless such an interpretation of the provisions of the Contract Documents would result in violation of such Law or Regulation).

3.04 *Amending and Supplementing Contract Documents*

- A. The Contract Documents may be amended to provide for additions, deletions, and revisions in the Work or to modify the terms and conditions thereof by either a Change Order or a Work Change Directive.
- B. The requirements of the Contract Documents may be supplemented, and minor variations and deviations in the Work may be authorized, by one or more of the following ways:
  1. A Field Order;
  2. Engineer's approval of a Shop Drawing or Sample (subject to the provisions of Paragraph 6.17.D.3); or

3. Engineer's written interpretation or clarification.

### 3.05 *Reuse of Documents*

- A. Contractor and any Subcontractor or Supplier shall not:
  1. have or acquire any title to or ownership rights in any of the Drawings, Specifications, or other documents (or copies of any thereof) prepared by or bearing the seal of Engineer or its consultants, including electronic media editions; or
  2. reuse any such Drawings, Specifications, other documents, or copies thereof on extensions of the Project or any other project without written consent of Owner and Engineer and specific written verification or adaptation by Engineer.
- B. The prohibitions of this Paragraph 3.05 will survive final payment, or termination of the Contract. Nothing herein shall preclude Contractor from retaining copies of the Contract Documents for record purposes.

### 3.06 *Electronic Data*

- A. Unless otherwise stated in the Supplementary Conditions, the data furnished by Owner or Engineer to Contractor, or by Contractor to Owner or Engineer, that may be relied upon are limited to the printed copies (also known as hard copies). Files in electronic media format of text, data, graphics, or other types are furnished only for the convenience of the receiving party. Any conclusion or information obtained or derived from such electronic files will be at the user's sole risk. If there is a discrepancy between the electronic files and the hard copies, the hard copies govern.
- B. Because data stored in electronic media format can deteriorate or be modified inadvertently or otherwise without authorization of the data's creator, the party receiving electronic files agrees that it will perform acceptance tests or procedures within 60 days, after which the receiving party shall be deemed to have accepted the data thus transferred. Any errors detected within the 60-day acceptance period will be corrected by the transferring party.
- C. When transferring documents in electronic media format, the transferring party makes no representations as to long term compatibility, usability, or readability of documents resulting from the use of software application packages, operating systems, or computer hardware differing from those used by the data's creator.

## **ARTICLE 4 – AVAILABILITY OF LANDS; SUBSURFACE AND PHYSICAL CONDITIONS; HAZARDOUS ENVIRONMENTAL CONDITIONS; REFERENCE POINTS**

### 4.01 *Availability of Lands*

- A. Owner shall furnish the Site. Owner shall notify Contractor of any encumbrances or restrictions not of general application but specifically related to use of the Site with which Contractor must comply in performing the Work. Owner will obtain in a timely manner and pay for easements for permanent structures or permanent changes in existing facilities. If Contractor and Owner are unable to agree on entitlement to or on the amount or extent, if any, of any adjustment in the

Contract Price or Contract Times, or both, as a result of any delay in Owner's furnishing the Site or a part thereof, Contractor may make a Claim therefor as provided in Paragraph 10.05.

- B. Upon reasonable written request, Owner shall furnish Contractor with a current statement of record legal title and legal description of the lands upon which the Work is to be performed and Owner's interest therein as necessary for giving notice of or filing a mechanic's or construction lien against such lands in accordance with applicable Laws and Regulations.
- C. Contractor shall provide for all additional lands and access thereto that may be required for temporary construction facilities or storage of materials and equipment.

#### 4.02 *Subsurface and Physical Conditions*

A. *Reports and Drawings:* The Supplementary Conditions identify:

- 1. those reports known to Owner of explorations and tests of subsurface conditions at or contiguous to the Site; and
- 2. those drawings known to Owner of physical conditions relating to existing surface or subsurface structures at the Site (except Underground Facilities).

B. *Limited Reliance by Contractor on Technical Data Authorized:* Contractor may rely upon the accuracy of the "technical data" contained in such reports and drawings, but such reports and drawings are not Contract Documents. Such "technical data" is identified in the Supplementary Conditions. Except for such reliance on such "technical data," Contractor may not rely upon or make any claim against Owner or Engineer, or any of their officers, directors, members, partners, employees, agents, consultants, or subcontractors with respect to:

- 1. the completeness of such reports and drawings for Contractor's purposes, including, but not limited to, any aspects of the means, methods, techniques, sequences, and procedures of construction to be employed by Contractor, and safety precautions and programs incident thereto; or
- 2. other data, interpretations, opinions, and information contained in such reports or shown or indicated in such drawings; or
- 3. any Contractor interpretation of or conclusion drawn from any "technical data" or any such other data, interpretations, opinions, or information.

#### 4.03 *Differing Subsurface or Physical Conditions*

A. *Notice:* If Contractor believes that any subsurface or physical condition that is uncovered or revealed either:

- 1. is of such a nature as to establish that any "technical data" on which Contractor is entitled to rely as provided in Paragraph 4.02 is materially inaccurate; or
- 2. is of such a nature as to require a change in the Contract Documents; or

3. differs materially from that shown or indicated in the Contract Documents; or
4. is of an unusual nature, and differs materially from conditions ordinarily encountered and generally recognized as inherent in work of the character provided for in the Contract Documents;

then Contractor shall, promptly after becoming aware thereof and before further disturbing the subsurface or physical conditions or performing any Work in connection therewith (except in an emergency as required by Paragraph 6.16.A), notify Owner and Engineer in writing about such condition. Contractor shall not further disturb such condition or perform any Work in connection therewith (except as aforesaid) until receipt of written order to do so.

B. *Engineer's Review:* After receipt of written notice as required by Paragraph 4.03.A, Engineer will promptly review the pertinent condition, determine the necessity of Owner's obtaining additional exploration or tests with respect thereto, and advise Owner in writing (with a copy to Contractor) of Engineer's findings and conclusions.

C. *Possible Price and Times Adjustments:*

1. The Contract Price or the Contract Times, or both, will be equitably adjusted to the extent that the existence of such differing subsurface or physical condition causes an increase or decrease in Contractor's cost of, or time required for, performance of the Work; subject, however, to the following:
  - a. such condition must meet any one or more of the categories described in Paragraph 4.03.A; and
  - b. with respect to Work that is paid for on a unit price basis, any adjustment in Contract Price will be subject to the provisions of Paragraphs 9.07 and 11.03.
2. Contractor shall not be entitled to any adjustment in the Contract Price or Contract Times if:
  - a. Contractor knew of the existence of such conditions at the time Contractor made a final commitment to Owner with respect to Contract Price and Contract Times by the submission of a Bid or becoming bound under a negotiated contract; or
  - b. the existence of such condition could reasonably have been discovered or revealed as a result of any examination, investigation, exploration, test, or study of the Site and contiguous areas required by the Bidding Requirements or Contract Documents to be conducted by or for Contractor prior to Contractor's making such final commitment; or
  - c. Contractor failed to give the written notice as required by Paragraph 4.03.A.
3. If Owner and Contractor are unable to agree on entitlement to or on the amount or extent, if any, of any adjustment in the Contract Price or Contract Times, or both, a Claim may be made therefor as provided in Paragraph 10.05. However, neither Owner or Engineer, or any of their officers, directors, members, partners, employees, agents, consultants, or subcontractors shall be liable to Contractor for any claims, costs, losses, or damages (including but not limited to all fees and charges of engineers, architects, attorneys, and other



professionals and all court or arbitration or other dispute resolution costs) sustained by Contractor on or in connection with any other project or anticipated project.

#### 4.04 *Underground Facilities*

A. *Shown or Indicated:* The information and data shown or indicated in the Contract Documents with respect to existing Underground Facilities at or contiguous to the Site is based on information and data furnished to Owner or Engineer by the owners of such Underground Facilities, including Owner, or by others. Unless it is otherwise expressly provided in the Supplementary Conditions:

1. Owner and Engineer shall not be responsible for the accuracy or completeness of any such information or data provided by others; and
2. the cost of all of the following will be included in the Contract Price, and Contractor shall have full responsibility for:
  - a. reviewing and checking all such information and data;
  - b. locating all Underground Facilities shown or indicated in the Contract Documents;
  - c. coordination of the Work with the owners of such Underground Facilities, including Owner, during construction; and
  - d. the safety and protection of all such Underground Facilities and repairing any damage thereto resulting from the Work.

B. *Not Shown or Indicated:*

1. If an Underground Facility is uncovered or revealed at or contiguous to the Site which was not shown or indicated, or not shown or indicated with reasonable accuracy in the Contract Documents, Contractor shall, promptly after becoming aware thereof and before further disturbing conditions affected thereby or performing any Work in connection therewith (except in an emergency as required by Paragraph 6.16.A), identify the owner of such Underground Facility and give written notice to that owner and to Owner and Engineer. Engineer will promptly review the Underground Facility and determine the extent, if any, to which a change is required in the Contract Documents to reflect and document the consequences of the existence or location of the Underground Facility. During such time, Contractor shall be responsible for the safety and protection of such Underground Facility.
2. If Engineer concludes that a change in the Contract Documents is required, a Work Change Directive or a Change Order will be issued to reflect and document such consequences. An equitable adjustment shall be made in the Contract Price or Contract Times, or both, to the extent that they are attributable to the existence or location of any Underground Facility that was not shown or indicated or not shown or indicated with reasonable accuracy in the Contract Documents and that Contractor did not know of and could not reasonably have been expected to be aware of or to have anticipated. If Owner and Contractor are unable to agree on entitlement to or on the amount or extent, if any, of any such adjustment in Contract Price

or Contract Times, Owner or Contractor may make a Claim therefor as provided in Paragraph 10.05.

#### 4.05 *Reference Points*

- A. Owner shall provide engineering surveys to establish reference points for construction which in Engineer's judgment are necessary to enable Contractor to proceed with the Work. Contractor shall be responsible for laying out the Work, shall protect and preserve the established reference points and property monuments, and shall make no changes or relocations without the prior written approval of Owner. Contractor shall report to Engineer whenever any reference point or property monument is lost or destroyed or requires relocation because of necessary changes in grades or locations, and shall be responsible for the accurate replacement or relocation of such reference points or property monuments by professionally qualified personnel.

#### 4.06 *Hazardous Environmental Condition at Site*

- A. *Reports and Drawings:* The Supplementary Conditions identify those reports and drawings known to Owner relating to Hazardous Environmental Conditions that have been identified at the Site.
- B. *Limited Reliance by Contractor on Technical Data Authorized:* Contractor may rely upon the accuracy of the "technical data" contained in such reports and drawings, but such reports and drawings are not Contract Documents. Such "technical data" is identified in the Supplementary Conditions. Except for such reliance on such "technical data," Contractor may not rely upon or make any claim against Owner or Engineer, or any of their officers, directors, members, partners, employees, agents, consultants, or subcontractors with respect to:
1. the completeness of such reports and drawings for Contractor's purposes, including, but not limited to, any aspects of the means, methods, techniques, sequences and procedures of construction to be employed by Contractor and safety precautions and programs incident thereto; or
  2. other data, interpretations, opinions and information contained in such reports or shown or indicated in such drawings; or
  3. any Contractor interpretation of or conclusion drawn from any "technical data" or any such other data, interpretations, opinions or information.
- C. Contractor shall not be responsible for any Hazardous Environmental Condition uncovered or revealed at the Site which was not shown or indicated in Drawings or Specifications or identified in the Contract Documents to be within the scope of the Work. Contractor shall be responsible for a Hazardous Environmental Condition created with any materials brought to the Site by Contractor, Subcontractors, Suppliers, or anyone else for whom Contractor is responsible.
- D. If Contractor encounters a Hazardous Environmental Condition or if Contractor or anyone for whom Contractor is responsible creates a Hazardous Environmental Condition, Contractor shall immediately: (i) secure or otherwise isolate such condition; (ii) stop all Work in connection with such condition and in any area affected thereby (except in an emergency as required by

Paragraph 6.16.A); and (iii) notify Owner and Engineer (and promptly thereafter confirm such notice in writing). Owner shall promptly consult with Engineer concerning the necessity for Owner to retain a qualified expert to evaluate such condition or take corrective action, if any. Promptly after consulting with Engineer, Owner shall take such actions as are necessary to permit Owner to timely obtain required permits and provide Contractor the written notice required by Paragraph 4.06.E.

- E. Contractor shall not be required to resume Work in connection with such condition or in any affected area until after Owner has obtained any required permits related thereto and delivered written notice to Contractor: (i) specifying that such condition and any affected area is or has been rendered safe for the resumption of Work; or (ii) specifying any special conditions under which such Work may be resumed safely. If Owner and Contractor cannot agree as to entitlement to or on the amount or extent, if any, of any adjustment in Contract Price or Contract Times, or both, as a result of such Work stoppage or such special conditions under which Work is agreed to be resumed by Contractor, either party may make a Claim therefor as provided in Paragraph 10.05.
- F. If after receipt of such written notice Contractor does not agree to resume such Work based on a reasonable belief it is unsafe, or does not agree to resume such Work under such special conditions, then Owner may order the portion of the Work that is in the area affected by such condition to be deleted from the Work. If Owner and Contractor cannot agree as to entitlement to or on the amount or extent, if any, of an adjustment in Contract Price or Contract Times as a result of deleting such portion of the Work, then either party may make a Claim therefor as provided in Paragraph 10.05. Owner may have such deleted portion of the Work performed by Owner's own forces or others in accordance with Article 7.
- G. To the fullest extent permitted by Laws and Regulations, Owner shall indemnify and hold harmless Contractor, Subcontractors, and Engineer, and the officers, directors, members, partners, employees, agents, consultants, and subcontractors of each and any of them from and against all claims, costs, losses, and damages (including but not limited to all fees and charges of engineers, architects, attorneys, and other professionals and all court or arbitration or other dispute resolution costs) arising out of or relating to a Hazardous Environmental Condition, provided that such Hazardous Environmental Condition: (i) was not shown or indicated in the Drawings or Specifications or identified in the Contract Documents to be included within the scope of the Work, and (ii) was not created by Contractor or by anyone for whom Contractor is responsible. Nothing in this Paragraph 4.06.G shall obligate Owner to indemnify any individual or entity from and against the consequences of that individual's or entity's own negligence.
- H. To the fullest extent permitted by Laws and Regulations, Contractor shall indemnify and hold harmless Owner and Engineer, and the officers, directors, members, partners, employees, agents, consultants, and subcontractors of each and any of them from and against all claims, costs, losses, and damages (including but not limited to all fees and charges of engineers, architects, attorneys, and other professionals and all court or arbitration or other dispute resolution costs) arising out of or relating to a Hazardous Environmental Condition created by Contractor or by anyone for whom Contractor is responsible. Nothing in this Paragraph 4.06.H shall obligate Contractor to indemnify any individual or entity from and against the consequences of that individual's or entity's own negligence.

- I. The provisions of Paragraphs 4.02, 4.03, and 4.04 do not apply to a Hazardous Environmental Condition uncovered or revealed at the Site.

## **ARTICLE 5 – BONDS AND INSURANCE**

### *5.01 Performance, Payment, and Other Bonds*

- A. Contractor shall furnish performance and payment bonds, each in an amount at least equal to the Contract Price as security for the faithful performance and payment of all of Contractor's obligations under the Contract Documents. These bonds shall remain in effect until one year after the date when final payment becomes due or until completion of the correction period specified in Paragraph 13.07, whichever is later, except as provided otherwise by Laws or Regulations or by the Contract Documents. Contractor shall also furnish such other bonds as are required by the Contract Documents.
- B. All bonds shall be in the form prescribed by the Contract Documents except as provided otherwise by Laws or Regulations, and shall be executed by such sureties as are named in the list of "Companies Holding Certificates of Authority as Acceptable Sureties on Federal Bonds and as Acceptable Reinsuring Companies" as published in Circular 570 (amended) by the Financial Management Service, Surety Bond Branch, U.S. Department of the Treasury. All bonds signed by an agent or attorney-in-fact must be accompanied by a certified copy of that individual's authority to bind the surety. The evidence of authority shall show that it is effective on the date the agent or attorney-in-fact signed each bond.
- C. If the surety on any bond furnished by Contractor is declared bankrupt or becomes insolvent or its right to do business is terminated in any state where any part of the Project is located or it ceases to meet the requirements of Paragraph 5.01.B, Contractor shall promptly notify Owner and Engineer and shall, within 20 days after the event giving rise to such notification, provide another bond and surety, both of which shall comply with the requirements of Paragraphs 5.01.B and 5.02.

### *5.02 Licensed Sureties and Insurers*

- A. All bonds and insurance required by the Contract Documents to be purchased and maintained by Owner or Contractor shall be obtained from surety or insurance companies that are duly licensed or authorized in the jurisdiction in which the Project is located to issue bonds or insurance policies for the limits and coverages so required. Such surety and insurance companies shall also meet such additional requirements and qualifications as may be provided in the Supplementary Conditions.

### *5.03 Certificates of Insurance*

- A. Contractor shall deliver to Owner, with copies to each additional insured and loss payee identified in the Supplementary Conditions, certificates of insurance (and other evidence of insurance requested by Owner or any other additional insured) which Contractor is required to purchase and maintain.

- B. Owner shall deliver to Contractor, with copies to each additional insured and loss payee identified in the Supplementary Conditions, certificates of insurance (and other evidence of insurance requested by Contractor or any other additional insured) which Owner is required to purchase and maintain.
- C. Failure of Owner to demand such certificates or other evidence of Contractor's full compliance with these insurance requirements or failure of Owner to identify a deficiency in compliance from the evidence provided shall not be construed as a waiver of Contractor's obligation to maintain such insurance.
- D. Owner does not represent that insurance coverage and limits established in this Contract necessarily will be adequate to protect Contractor.
- E. The insurance and insurance limits required herein shall not be deemed as a limitation on Contractor's liability under the indemnities granted to Owner in the Contract Documents.

#### 5.04 *Contractor's Insurance*

- A. Contractor shall purchase and maintain such insurance as is appropriate for the Work being performed and as will provide protection from claims set forth below which may arise out of or result from Contractor's performance of the Work and Contractor's other obligations under the Contract Documents, whether it is to be performed by Contractor, any Subcontractor or Supplier, or by anyone directly or indirectly employed by any of them to perform any of the Work, or by anyone for whose acts any of them may be liable:
  - 1. claims under workers' compensation, disability benefits, and other similar employee benefit acts;
  - 2. claims for damages because of bodily injury, occupational sickness or disease, or death of Contractor's employees;
  - 3. claims for damages because of bodily injury, sickness or disease, or death of any person other than Contractor's employees;
  - 4. claims for damages insured by reasonably available personal injury liability coverage which are sustained:
    - a. by any person as a result of an offense directly or indirectly related to the employment of such person by Contractor, or
    - b. by any other person for any other reason;
  - 5. claims for damages, other than to the Work itself, because of injury to or destruction of tangible property wherever located, including loss of use resulting therefrom; and
  - 6. claims for damages because of bodily injury or death of any person or property damage arising out of the ownership, maintenance or use of any motor vehicle.
- B. The policies of insurance required by this Paragraph 5.04 shall:

1. with respect to insurance required by Paragraphs 5.04.A.3 through 5.04.A.6 inclusive, be written on an occurrence basis, include as additional insureds (subject to any customary exclusion regarding professional liability) Owner and Engineer, and any other individuals or entities identified in the Supplementary Conditions, all of whom shall be listed as additional insureds, and include coverage for the respective officers, directors, members, partners, employees, agents, consultants, and subcontractors of each and any of all such additional insureds, and the insurance afforded to these additional insureds shall provide primary coverage for all claims covered thereby;
2. include at least the specific coverages and be written for not less than the limits of liability provided in the Supplementary Conditions or required by Laws or Regulations, whichever is greater;
3. include contractual liability insurance covering Contractor's indemnity obligations under Paragraphs 6.11 and 6.20;
4. contain a provision or endorsement that the coverage afforded will not be canceled, materially changed or renewal refused until at least 30 days prior written notice has been given to Owner and Contractor and to each other additional insured identified in the Supplementary Conditions to whom a certificate of insurance has been issued (and the certificates of insurance furnished by the Contractor pursuant to Paragraph 5.03 will so provide);
5. remain in effect at least until final payment and at all times thereafter when Contractor may be correcting, removing, or replacing defective Work in accordance with Paragraph 13.07; and
6. include completed operations coverage:
  - a. Such insurance shall remain in effect for two years after final payment.
  - b. Contractor shall furnish Owner and each other additional insured identified in the Supplementary Conditions, to whom a certificate of insurance has been issued, evidence satisfactory to Owner and any such additional insured of continuation of such insurance at final payment and one year thereafter.

#### 5.05 *Owner's Liability Insurance*

- A. In addition to the insurance required to be provided by Contractor under Paragraph 5.04, Owner, at Owner's option, may purchase and maintain at Owner's expense Owner's own liability insurance as will protect Owner against claims which may arise from operations under the Contract Documents.

#### 5.06 *Property Insurance*

- A. Unless otherwise provided in the Supplementary Conditions, Owner shall purchase and maintain property insurance upon the Work at the Site in the amount of the full replacement cost thereof (subject to such deductible amounts as may be provided in the Supplementary Conditions or required by Laws and Regulations). This insurance shall:

1. include the interests of Owner, Contractor, Subcontractors, and Engineer, and any other individuals or entities identified in the Supplementary Conditions, and the officers, directors, members, partners, employees, agents, consultants, and subcontractors of each and any of them, each of whom is deemed to have an insurable interest and shall be listed as a loss payee;
  2. be written on a Builder's Risk "all-risk" policy form that shall at least include insurance for physical loss or damage to the Work, temporary buildings, falsework, and materials and equipment in transit, and shall insure against at least the following perils or causes of loss: fire, lightning, extended coverage, theft, vandalism and malicious mischief, earthquake, collapse, debris removal, demolition occasioned by enforcement of Laws and Regulations, water damage (other than that caused by flood), and such other perils or causes of loss as may be specifically required by the Supplementary Conditions.
  3. include expenses incurred in the repair or replacement of any insured property (including but not limited to fees and charges of engineers and architects);
  4. cover materials and equipment stored at the Site or at another location that was agreed to in writing by Owner prior to being incorporated in the Work, provided that such materials and equipment have been included in an Application for Payment recommended by Engineer;
  5. allow for partial utilization of the Work by Owner;
  6. include testing and startup; and
  7. be maintained in effect until final payment is made unless otherwise agreed to in writing by Owner, Contractor, and Engineer with 30 days written notice to each other loss payee to whom a certificate of insurance has been issued.
- B. Owner shall purchase and maintain such equipment breakdown insurance or additional property insurance as may be required by the Supplementary Conditions or Laws and Regulations which will include the interests of Owner, Contractor, Subcontractors, and Engineer, and any other individuals or entities identified in the Supplementary Conditions, and the officers, directors, members, partners, employees, agents, consultants and subcontractors of each and any of them, each of whom is deemed to have an insurable interest and shall be listed as a loss payee.
- C. All the policies of insurance (and the certificates or other evidence thereof) required to be purchased and maintained in accordance with this Paragraph 5.06 will contain a provision or endorsement that the coverage afforded will not be canceled or materially changed or renewal refused until at least 30 days prior written notice has been given to Owner and Contractor and to each other loss payee to whom a certificate of insurance has been issued and will contain waiver provisions in accordance with Paragraph 5.07.
- D. Owner shall not be responsible for purchasing and maintaining any property insurance specified in this Paragraph 5.06 to protect the interests of Contractor, Subcontractors, or others in the Work to the extent of any deductible amounts that are identified in the Supplementary Conditions. The risk of loss within such identified deductible amount will be borne by Contractor, Subcontractors, or others suffering any such loss, and if any of them wishes property

insurance coverage within the limits of such amounts, each may purchase and maintain it at the purchaser's own expense.

- E. If Contractor requests in writing that other special insurance be included in the property insurance policies provided under this Paragraph 5.06, Owner shall, if possible, include such insurance, and the cost thereof will be charged to Contractor by appropriate Change Order. Prior to commencement of the Work at the Site, Owner shall in writing advise Contractor whether or not such other insurance has been procured by Owner.

#### 5.07 *Waiver of Rights*

- A. Owner and Contractor intend that all policies purchased in accordance with Paragraph 5.06 will protect Owner, Contractor, Subcontractors, and Engineer, and all other individuals or entities identified in the Supplementary Conditions as loss payees (and the officers, directors, members, partners, employees, agents, consultants, and subcontractors of each and any of them) in such policies and will provide primary coverage for all losses and damages caused by the perils or causes of loss covered thereby. All such policies shall contain provisions to the effect that in the event of payment of any loss or damage the insurers will have no rights of recovery against any of the insureds or loss payees thereunder. Owner and Contractor waive all rights against each other and their respective officers, directors, members, partners, employees, agents, consultants and subcontractors of each and any of them for all losses and damages caused by, arising out of or resulting from any of the perils or causes of loss covered by such policies and any other property insurance applicable to the Work; and, in addition, waive all such rights against Subcontractors and Engineer, and all other individuals or entities identified in the Supplementary Conditions as loss payees (and the officers, directors, members, partners, employees, agents, consultants, and subcontractors of each and any of them) under such policies for losses and damages so caused. None of the above waivers shall extend to the rights that any party making such waiver may have to the proceeds of insurance held by Owner as trustee or otherwise payable under any policy so issued.
- B. Owner waives all rights against Contractor, Subcontractors, and Engineer, and the officers, directors, members, partners, employees, agents, consultants and subcontractors of each and any of them for:
  - 1. loss due to business interruption, loss of use, or other consequential loss extending beyond direct physical loss or damage to Owner's property or the Work caused by, arising out of, or resulting from fire or other perils whether or not insured by Owner; and
  - 2. loss or damage to the completed Project or part thereof caused by, arising out of, or resulting from fire or other insured peril or cause of loss covered by any property insurance maintained on the completed Project or part thereof by Owner during partial utilization pursuant to Paragraph 14.05, after Substantial Completion pursuant to Paragraph 14.04, or after final payment pursuant to Paragraph 14.07.
- C. Any insurance policy maintained by Owner covering any loss, damage or consequential loss referred to in Paragraph 5.07.B shall contain provisions to the effect that in the event of payment of any such loss, damage, or consequential loss, the insurers will have no rights of recovery



against Contractor, Subcontractors, or Engineer, and the officers, directors, members, partners, employees, agents, consultants and subcontractors of each and any of them.

5.08 *Receipt and Application of Insurance Proceeds*

- A. Any insured loss under the policies of insurance required by Paragraph 5.06 will be adjusted with Owner and made payable to Owner as fiduciary for the loss payees, as their interests may appear, subject to the requirements of any applicable mortgage clause and of Paragraph 5.08.B. Owner shall deposit in a separate account any money so received and shall distribute it in accordance with such agreement as the parties in interest may reach. If no other special agreement is reached, the damaged Work shall be repaired or replaced, the moneys so received applied on account thereof, and the Work and the cost thereof covered by an appropriate Change Order.
- B. Owner as fiduciary shall have power to adjust and settle any loss with the insurers unless one of the parties in interest shall object in writing within 15 days after the occurrence of loss to Owner's exercise of this power. If such objection be made, Owner as fiduciary shall make settlement with the insurers in accordance with such agreement as the parties in interest may reach. If no such agreement among the parties in interest is reached, Owner as fiduciary shall adjust and settle the loss with the insurers and, if required in writing by any party in interest, Owner as fiduciary shall give bond for the proper performance of such duties.

5.09 *Acceptance of Bonds and Insurance; Option to Replace*

- A. If either Owner or Contractor has any objection to the coverage afforded by or other provisions of the bonds or insurance required to be purchased and maintained by the other party in accordance with Article 5 on the basis of non-conformance with the Contract Documents, the objecting party shall so notify the other party in writing within 10 days after receipt of the certificates (or other evidence requested) required by Paragraph 2.01.B. Owner and Contractor shall each provide to the other such additional information in respect of insurance provided as the other may reasonably request. If either party does not purchase or maintain all of the bonds and insurance required of such party by the Contract Documents, such party shall notify the other party in writing of such failure to purchase prior to the start of the Work, or of such failure to maintain prior to any change in the required coverage. Without prejudice to any other right or remedy, the other party may elect to obtain equivalent bonds or insurance to protect such other party's interests at the expense of the party who was required to provide such coverage, and a Change Order shall be issued to adjust the Contract Price accordingly.

5.10 *Partial Utilization, Acknowledgment of Property Insurer*

- A. If Owner finds it necessary to occupy or use a portion or portions of the Work prior to Substantial Completion of all the Work as provided in Paragraph 14.05, no such use or occupancy shall commence before the insurers providing the property insurance pursuant to Paragraph 5.06 have acknowledged notice thereof and in writing effected any changes in coverage necessitated thereby. The insurers providing the property insurance shall consent by endorsement on the policy or policies, but the property insurance shall not be canceled or permitted to lapse on account of any such partial use or occupancy.

## ARTICLE 6 – CONTRACTOR’S RESPONSIBILITIES

### 6.01 *Supervision and Superintendence*

- A. Contractor shall supervise, inspect, and direct the Work competently and efficiently, devoting such attention thereto and applying such skills and expertise as may be necessary to perform the Work in accordance with the Contract Documents. Contractor shall be solely responsible for the means, methods, techniques, sequences, and procedures of construction. Contractor shall not be responsible for the negligence of Owner or Engineer in the design or specification of a specific means, method, technique, sequence, or procedure of construction which is shown or indicated in and expressly required by the Contract Documents.
- B. At all times during the progress of the Work, Contractor shall assign a competent resident superintendent who shall not be replaced without written notice to Owner and Engineer except under extraordinary circumstances.

### 6.02 *Labor; Working Hours*

- A. Contractor shall provide competent, suitably qualified personnel to survey and lay out the Work and perform construction as required by the Contract Documents. Contractor shall at all times maintain good discipline and order at the Site.
- B. Except as otherwise required for the safety or protection of persons or the Work or property at the Site or adjacent thereto, and except as otherwise stated in the Contract Documents, all Work at the Site shall be performed during regular working hours. Contractor will not permit the performance of Work on a Saturday, Sunday, or any legal holiday without Owner’s written consent (which will not be unreasonably withheld) given after prior written notice to Engineer.

### 6.03 *Services, Materials, and Equipment*

- A. Unless otherwise specified in the Contract Documents, Contractor shall provide and assume full responsibility for all services, materials, equipment, labor, transportation, construction equipment and machinery, tools, appliances, fuel, power, light, heat, telephone, water, sanitary facilities, temporary facilities, and all other facilities and incidentals necessary for the performance, testing, start-up, and completion of the Work.
- B. All materials and equipment incorporated into the Work shall be as specified or, if not specified, shall be of good quality and new, except as otherwise provided in the Contract Documents. All special warranties and guarantees required by the Specifications shall expressly run to the benefit of Owner. If required by Engineer, Contractor shall furnish satisfactory evidence (including reports of required tests) as to the source, kind, and quality of materials and equipment.
- C. All materials and equipment shall be stored, applied, installed, connected, erected, protected, used, cleaned, and conditioned in accordance with instructions of the applicable Supplier, except as otherwise may be provided in the Contract Documents.

#### 6.04 *Progress Schedule*

- A. Contractor shall adhere to the Progress Schedule established in accordance with Paragraph 2.07 as it may be adjusted from time to time as provided below.
1. Contractor shall submit to Engineer for acceptance (to the extent indicated in Paragraph 2.07) proposed adjustments in the Progress Schedule that will not result in changing the Contract Times. Such adjustments will comply with any provisions of the General Requirements applicable thereto.
  2. Proposed adjustments in the Progress Schedule that will change the Contract Times shall be submitted in accordance with the requirements of Article 12. Adjustments in Contract Times may only be made by a Change Order.

#### 6.05 *Substitutes and "Or-Equals"*

- A. Whenever an item of material or equipment is specified or described in the Contract Documents by using the name of a proprietary item or the name of a particular Supplier, the specification or description is intended to establish the type, function, appearance, and quality required. Unless the specification or description contains or is followed by words reading that no like, equivalent, or "or-equal" item or no substitution is permitted, other items of material or equipment or material or equipment of other Suppliers may be submitted to Engineer for review under the circumstances described below.
1. *"Or-Equal" Items:* If in Engineer's sole discretion an item of material or equipment proposed by Contractor is functionally equal to that named and sufficiently similar so that no change in related Work will be required, it may be considered by Engineer as an "or-equal" item, in which case review and approval of the proposed item may, in Engineer's sole discretion, be accomplished without compliance with some or all of the requirements for approval of proposed substitute items. For the purposes of this Paragraph 6.05.A.1, a proposed item of material or equipment will be considered functionally equal to an item so named if:
    - a. in the exercise of reasonable judgment Engineer determines that:
      - 1) it is at least equal in materials of construction, quality, durability, appearance, strength, and design characteristics;
      - 2) it will reliably perform at least equally well the function and achieve the results imposed by the design concept of the completed Project as a functioning whole; and
      - 3) it has a proven record of performance and availability of responsive service.
    - b. Contractor certifies that, if approved and incorporated into the Work:
      - 1) there will be no increase in cost to the Owner or increase in Contract Times; and
      - 2) it will conform substantially to the detailed requirements of the item named in the Contract Documents.

2. *Substitute Items:*

- a. If in Engineer's sole discretion an item of material or equipment proposed by Contractor does not qualify as an "or-equal" item under Paragraph 6.05.A.1, it will be considered a proposed substitute item.
- b. Contractor shall submit sufficient information as provided below to allow Engineer to determine if the item of material or equipment proposed is essentially equivalent to that named and an acceptable substitute therefor. Requests for review of proposed substitute items of material or equipment will not be accepted by Engineer from anyone other than Contractor.
- c. The requirements for review by Engineer will be as set forth in Paragraph 6.05.A.2.d, as supplemented by the General Requirements, and as Engineer may decide is appropriate under the circumstances.
- d. Contractor shall make written application to Engineer for review of a proposed substitute item of material or equipment that Contractor seeks to furnish or use. The application:
  - 1) shall certify that the proposed substitute item will:
    - a) perform adequately the functions and achieve the results called for by the general design,
    - b) be similar in substance to that specified, and
    - c) be suited to the same use as that specified;
  - 2) will state:
    - a) the extent, if any, to which the use of the proposed substitute item will prejudice Contractor's achievement of Substantial Completion on time,
    - b) whether use of the proposed substitute item in the Work will require a change in any of the Contract Documents (or in the provisions of any other direct contract with Owner for other work on the Project) to adapt the design to the proposed substitute item, and
    - c) whether incorporation or use of the proposed substitute item in connection with the Work is subject to payment of any license fee or royalty;
  - 3) will identify:
    - a) all variations of the proposed substitute item from that specified, and
    - b) available engineering, sales, maintenance, repair, and replacement services; and

- 4) shall contain an itemized estimate of all costs or credits that will result directly or indirectly from use of such substitute item, including costs of redesign and claims of other contractors affected by any resulting change.
- B. *Substitute Construction Methods or Procedures:* If a specific means, method, technique, sequence, or procedure of construction is expressly required by the Contract Documents, Contractor may furnish or utilize a substitute means, method, technique, sequence, or procedure of construction approved by Engineer. Contractor shall submit sufficient information to allow Engineer, in Engineer's sole discretion, to determine that the substitute proposed is equivalent to that expressly called for by the Contract Documents. The requirements for review by Engineer will be similar to those provided in Paragraph 6.05.A.2.
- C. *Engineer's Evaluation:* Engineer will be allowed a reasonable time within which to evaluate each proposal or submittal made pursuant to Paragraphs 6.05.A and 6.05.B. Engineer may require Contractor to furnish additional data about the proposed substitute item. Engineer will be the sole judge of acceptability. No "or equal" or substitute will be ordered, installed or utilized until Engineer's review is complete, which will be evidenced by a Change Order in the case of a substitute and an approved Shop Drawing for an "or equal." Engineer will advise Contractor in writing of any negative determination.
- D. *Special Guarantee:* Owner may require Contractor to furnish at Contractor's expense a special performance guarantee or other surety with respect to any substitute.
- E. *Engineer's Cost Reimbursement:* Engineer will record Engineer's costs in evaluating a substitute proposed or submitted by Contractor pursuant to Paragraphs 6.05.A.2 and 6.05.B. Whether or not Engineer approves a substitute so proposed or submitted by Contractor, Contractor shall reimburse Owner for the reasonable charges of Engineer for evaluating each such proposed substitute. Contractor shall also reimburse Owner for the reasonable charges of Engineer for making changes in the Contract Documents (or in the provisions of any other direct contract with Owner) resulting from the acceptance of each proposed substitute.
- F. *Contractor's Expense:* Contractor shall provide all data in support of any proposed substitute or "or-equal" at Contractor's expense.

#### 6.06 *Concerning Subcontractors, Suppliers, and Others*

- A. Contractor shall not employ any Subcontractor, Supplier, or other individual or entity (including those acceptable to Owner as indicated in Paragraph 6.06.B), whether initially or as a replacement, against whom Owner may have reasonable objection. Contractor shall not be required to employ any Subcontractor, Supplier, or other individual or entity to furnish or perform any of the Work against whom Contractor has reasonable objection.
- B. If the Supplementary Conditions require the identity of certain Subcontractors, Suppliers, or other individuals or entities to be submitted to Owner in advance for acceptance by Owner by a specified date prior to the Effective Date of the Agreement, and if Contractor has submitted a list thereof in accordance with the Supplementary Conditions, Owner's acceptance (either in writing or by failing to make written objection thereto by the date indicated for acceptance or objection in the Bidding Documents or the Contract Documents) of any such Subcontractor, Supplier, or

other individual or entity so identified may be revoked on the basis of reasonable objection after due investigation. Contractor shall submit an acceptable replacement for the rejected Subcontractor, Supplier, or other individual or entity, and the Contract Price will be adjusted by the difference in the cost occasioned by such replacement, and an appropriate Change Order will be issued. No acceptance by Owner of any such Subcontractor, Supplier, or other individual or entity, whether initially or as a replacement, shall constitute a waiver of any right of Owner or Engineer to reject defective Work.

- C. Contractor shall be fully responsible to Owner and Engineer for all acts and omissions of the Subcontractors, Suppliers, and other individuals or entities performing or furnishing any of the Work just as Contractor is responsible for Contractor's own acts and omissions. Nothing in the Contract Documents:
1. shall create for the benefit of any such Subcontractor, Supplier, or other individual or entity any contractual relationship between Owner or Engineer and any such Subcontractor, Supplier or other individual or entity; nor
  2. shall create any obligation on the part of Owner or Engineer to pay or to see to the payment of any moneys due any such Subcontractor, Supplier, or other individual or entity except as may otherwise be required by Laws and Regulations.
- D. Contractor shall be solely responsible for scheduling and coordinating the Work of Subcontractors, Suppliers, and other individuals or entities performing or furnishing any of the Work under a direct or indirect contract with Contractor.
- E. Contractor shall require all Subcontractors, Suppliers, and such other individuals or entities performing or furnishing any of the Work to communicate with Engineer through Contractor.
- F. The divisions and sections of the Specifications and the identifications of any Drawings shall not control Contractor in dividing the Work among Subcontractors or Suppliers or delineating the Work to be performed by any specific trade.
- G. All Work performed for Contractor by a Subcontractor or Supplier will be pursuant to an appropriate agreement between Contractor and the Subcontractor or Supplier which specifically binds the Subcontractor or Supplier to the applicable terms and conditions of the Contract Documents for the benefit of Owner and Engineer. Whenever any such agreement is with a Subcontractor or Supplier who is listed as a loss payee on the property insurance provided in Paragraph 5.06, the agreement between the Contractor and the Subcontractor or Supplier will contain provisions whereby the Subcontractor or Supplier waives all rights against Owner, Contractor, Engineer, and all other individuals or entities identified in the Supplementary Conditions to be listed as insureds or loss payees (and the officers, directors, members, partners, employees, agents, consultants, and subcontractors of each and any of them) for all losses and damages caused by, arising out of, relating to, or resulting from any of the perils or causes of loss covered by such policies and any other property insurance applicable to the Work. If the insurers on any such policies require separate waiver forms to be signed by any Subcontractor or Supplier, Contractor will obtain the same.

## 6.07 *Patent Fees and Royalties*

- A. Contractor shall pay all license fees and royalties and assume all costs incident to the use in the performance of the Work or the incorporation in the Work of any invention, design, process, product, or device which is the subject of patent rights or copyrights held by others. If a particular invention, design, process, product, or device is specified in the Contract Documents for use in the performance of the Work and if, to the actual knowledge of Owner or Engineer, its use is subject to patent rights or copyrights calling for the payment of any license fee or royalty to others, the existence of such rights shall be disclosed by Owner in the Contract Documents.
- B. To the fullest extent permitted by Laws and Regulations, Owner shall indemnify and hold harmless Contractor, and its officers, directors, members, partners, employees, agents, consultants, and subcontractors from and against all claims, costs, losses, and damages (including but not limited to all fees and charges of engineers, architects, attorneys, and other professionals, and all court or arbitration or other dispute resolution costs) arising out of or relating to any infringement of patent rights or copyrights incident to the use in the performance of the Work or resulting from the incorporation in the Work of any invention, design, process, product, or device specified in the Contract Documents, but not identified as being subject to payment of any license fee or royalty to others required by patent rights or copyrights.
- C. To the fullest extent permitted by Laws and Regulations, Contractor shall indemnify and hold harmless Owner and Engineer, and the officers, directors, members, partners, employees, agents, consultants and subcontractors of each and any of them from and against all claims, costs, losses, and damages (including but not limited to all fees and charges of engineers, architects, attorneys, and other professionals and all court or arbitration or other dispute resolution costs) arising out of or relating to any infringement of patent rights or copyrights incident to the use in the performance of the Work or resulting from the incorporation in the Work of any invention, design, process, product, or device not specified in the Contract Documents.

## 6.08 *Permits*

- A. Unless otherwise provided in the Supplementary Conditions, Contractor shall obtain and pay for all construction permits and licenses. Owner shall assist Contractor, when necessary, in obtaining such permits and licenses. Contractor shall pay all governmental charges and inspection fees necessary for the prosecution of the Work which are applicable at the time of opening of Bids, or, if there are no Bids, on the Effective Date of the Agreement. Owner shall pay all charges of utility owners for connections for providing permanent service to the Work.

## 6.09 *Laws and Regulations*

- A. Contractor shall give all notices required by and shall comply with all Laws and Regulations applicable to the performance of the Work. Except where otherwise expressly required by applicable Laws and Regulations, neither Owner nor Engineer shall be responsible for monitoring Contractor's compliance with any Laws or Regulations.
- B. If Contractor performs any Work knowing or having reason to know that it is contrary to Laws or Regulations, Contractor shall bear all claims, costs, losses, and damages (including but not limited to all fees and charges of engineers, architects, attorneys, and other professionals and all

court or arbitration or other dispute resolution costs) arising out of or relating to such Work. However, it shall not be Contractor's responsibility to make certain that the Specifications and Drawings are in accordance with Laws and Regulations, but this shall not relieve Contractor of Contractor's obligations under Paragraph 3.03.

- C. Changes in Laws or Regulations not known at the time of opening of Bids (or, on the Effective Date of the Agreement if there were no Bids) having an effect on the cost or time of performance of the Work shall be the subject of an adjustment in Contract Price or Contract Times. If Owner and Contractor are unable to agree on entitlement to or on the amount or extent, if any, of any such adjustment, a Claim may be made therefor as provided in Paragraph 10.05.

#### 6.10 *Taxes*

- A. Contractor shall pay all sales, consumer, use, and other similar taxes required to be paid by Contractor in accordance with the Laws and Regulations of the place of the Project which are applicable during the performance of the Work.

#### 6.11 *Use of Site and Other Areas*

##### A. *Limitation on Use of Site and Other Areas:*

1. Contractor shall confine construction equipment, the storage of materials and equipment, and the operations of workers to the Site and other areas permitted by Laws and Regulations, and shall not unreasonably encumber the Site and other areas with construction equipment or other materials or equipment. Contractor shall assume full responsibility for any damage to any such land or area, or to the owner or occupant thereof, or of any adjacent land or areas resulting from the performance of the Work.
2. Should any claim be made by any such owner or occupant because of the performance of the Work, Contractor shall promptly settle with such other party by negotiation or otherwise resolve the claim by arbitration or other dispute resolution proceeding or at law.
3. To the fullest extent permitted by Laws and Regulations, Contractor shall indemnify and hold harmless Owner and Engineer, and the officers, directors, members, partners, employees, agents, consultants and subcontractors of each and any of them from and against all claims, costs, losses, and damages (including but not limited to all fees and charges of engineers, architects, attorneys, and other professionals and all court or arbitration or other dispute resolution costs) arising out of or relating to any claim or action, legal or equitable, brought by any such owner or occupant against Owner, Engineer, or any other party indemnified hereunder to the extent caused by or based upon Contractor's performance of the Work.

- B. *Removal of Debris During Performance of the Work:* During the progress of the Work Contractor shall keep the Site and other areas free from accumulations of waste materials, rubbish, and other debris. Removal and disposal of such waste materials, rubbish, and other debris shall conform to applicable Laws and Regulations.

- C. *Cleaning:* Prior to Substantial Completion of the Work Contractor shall clean the Site and the Work and make it ready for utilization by Owner. At the completion of the Work Contractor



shall remove from the Site all tools, appliances, construction equipment and machinery, and surplus materials and shall restore to original condition all property not designated for alteration by the Contract Documents.

- D. *Loading Structures:* Contractor shall not load nor permit any part of any structure to be loaded in any manner that will endanger the structure, nor shall Contractor subject any part of the Work or adjacent property to stresses or pressures that will endanger it.

#### 6.12 *Record Documents*

- A. Contractor shall maintain in a safe place at the Site one record copy of all Drawings, Specifications, Addenda, Change Orders, Work Change Directives, Field Orders, and written interpretations and clarifications in good order and annotated to show changes made during construction. These record documents together with all approved Samples and a counterpart of all approved Shop Drawings will be available to Engineer for reference. Upon completion of the Work, these record documents, Samples, and Shop Drawings will be delivered to Engineer for Owner.

#### 6.13 *Safety and Protection*

- A. Contractor shall be solely responsible for initiating, maintaining and supervising all safety precautions and programs in connection with the Work. Such responsibility does not relieve Subcontractors of their responsibility for the safety of persons or property in the performance of their work, nor for compliance with applicable safety Laws and Regulations. Contractor shall take all necessary precautions for the safety of, and shall provide the necessary protection to prevent damage, injury or loss to:
1. all persons on the Site or who may be affected by the Work;
  2. all the Work and materials and equipment to be incorporated therein, whether in storage on or off the Site; and
  3. other property at the Site or adjacent thereto, including trees, shrubs, lawns, walks, pavements, roadways, structures, utilities, and Underground Facilities not designated for removal, relocation, or replacement in the course of construction.
- B. Contractor shall comply with all applicable Laws and Regulations relating to the safety of persons or property, or to the protection of persons or property from damage, injury, or loss; and shall erect and maintain all necessary safeguards for such safety and protection. Contractor shall notify owners of adjacent property and of Underground Facilities and other utility owners when prosecution of the Work may affect them, and shall cooperate with them in the protection, removal, relocation, and replacement of their property.
- C. Contractor shall comply with the applicable requirements of Owner's safety programs, if any. The Supplementary Conditions identify any Owner's safety programs that are applicable to the Work.

- D. Contractor shall inform Owner and Engineer of the specific requirements of Contractor's safety program with which Owner's and Engineer's employees and representatives must comply while at the Site.
- E. All damage, injury, or loss to any property referred to in Paragraph 6.13.A.2 or 6.13.A.3 caused, directly or indirectly, in whole or in part, by Contractor, any Subcontractor, Supplier, or any other individual or entity directly or indirectly employed by any of them to perform any of the Work, or anyone for whose acts any of them may be liable, shall be remedied by Contractor (except damage or loss attributable to the fault of Drawings or Specifications or to the acts or omissions of Owner or Engineer or anyone employed by any of them, or anyone for whose acts any of them may be liable, and not attributable, directly or indirectly, in whole or in part, to the fault or negligence of Contractor or any Subcontractor, Supplier, or other individual or entity directly or indirectly employed by any of them).
- F. Contractor's duties and responsibilities for safety and for protection of the Work shall continue until such time as all the Work is completed and Engineer has issued a notice to Owner and Contractor in accordance with Paragraph 14.07.B that the Work is acceptable (except as otherwise expressly provided in connection with Substantial Completion).

6.14 *Safety Representative*

- A. Contractor shall designate a qualified and experienced safety representative at the Site whose duties and responsibilities shall be the prevention of accidents and the maintaining and supervising of safety precautions and programs.

6.15 *Hazard Communication Programs*

- A. Contractor shall be responsible for coordinating any exchange of material safety data sheets or other hazard communication information required to be made available to or exchanged between or among employers at the Site in accordance with Laws or Regulations.

6.16 *Emergencies*

- A. In emergencies affecting the safety or protection of persons or the Work or property at the Site or adjacent thereto, Contractor is obligated to act to prevent threatened damage, injury, or loss. Contractor shall give Engineer prompt written notice if Contractor believes that any significant changes in the Work or variations from the Contract Documents have been caused thereby or are required as a result thereof. If Engineer determines that a change in the Contract Documents is required because of the action taken by Contractor in response to such an emergency, a Work Change Directive or Change Order will be issued.

6.17 *Shop Drawings and Samples*

- A. Contractor shall submit Shop Drawings and Samples to Engineer for review and approval in accordance with the accepted Schedule of Submittals (as required by Paragraph 2.07). Each submittal will be identified as Engineer may require.

1. *Shop Drawings:*
    - a. Submit number of copies specified in the General Requirements.
    - b. Data shown on the Shop Drawings will be complete with respect to quantities, dimensions, specified performance and design criteria, materials, and similar data to show Engineer the services, materials, and equipment Contractor proposes to provide and to enable Engineer to review the information for the limited purposes required by Paragraph 6.17.D.
  2. *Samples:*
    - a. Submit number of Samples specified in the Specifications.
    - b. Clearly identify each Sample as to material, Supplier, pertinent data such as catalog numbers, the use for which intended and other data as Engineer may require to enable Engineer to review the submittal for the limited purposes required by Paragraph 6.17.D.
- B. Where a Shop Drawing or Sample is required by the Contract Documents or the Schedule of Submittals, any related Work performed prior to Engineer's review and approval of the pertinent submittal will be at the sole expense and responsibility of Contractor.
- C. *Submittal Procedures:*
1. Before submitting each Shop Drawing or Sample, Contractor shall have:
    - a. reviewed and coordinated each Shop Drawing or Sample with other Shop Drawings and Samples and with the requirements of the Work and the Contract Documents;
    - b. determined and verified all field measurements, quantities, dimensions, specified performance and design criteria, installation requirements, materials, catalog numbers, and similar information with respect thereto;
    - c. determined and verified the suitability of all materials offered with respect to the indicated application, fabrication, shipping, handling, storage, assembly, and installation pertaining to the performance of the Work; and
    - d. determined and verified all information relative to Contractor's responsibilities for means, methods, techniques, sequences, and procedures of construction, and safety precautions and programs incident thereto.
  2. Each submittal shall bear a stamp or specific written certification that Contractor has satisfied Contractor's obligations under the Contract Documents with respect to Contractor's review and approval of that submittal.
  3. With each submittal, Contractor shall give Engineer specific written notice of any variations that the Shop Drawing or Sample may have from the requirements of the Contract Documents. This notice shall be both a written communication separate from the Shop

Drawings or Sample submittal; and, in addition, by a specific notation made on each Shop Drawing or Sample submitted to Engineer for review and approval of each such variation.

D. *Engineer's Review:*

1. Engineer will provide timely review of Shop Drawings and Samples in accordance with the Schedule of Submittals acceptable to Engineer. Engineer's review and approval will be only to determine if the items covered by the submittals will, after installation or incorporation in the Work, conform to the information given in the Contract Documents and be compatible with the design concept of the completed Project as a functioning whole as indicated by the Contract Documents.
2. Engineer's review and approval will not extend to means, methods, techniques, sequences, or procedures of construction (except where a particular means, method, technique, sequence, or procedure of construction is specifically and expressly called for by the Contract Documents) or to safety precautions or programs incident thereto. The review and approval of a separate item as such will not indicate approval of the assembly in which the item functions.
3. Engineer's review and approval shall not relieve Contractor from responsibility for any variation from the requirements of the Contract Documents unless Contractor has complied with the requirements of Paragraph 6.17.C.3 and Engineer has given written approval of each such variation by specific written notation thereof incorporated in or accompanying the Shop Drawing or Sample. Engineer's review and approval shall not relieve Contractor from responsibility for complying with the requirements of Paragraph 6.17.C.1.

E. *Resubmittal Procedures:*

1. Contractor shall make corrections required by Engineer and shall return the required number of corrected copies of Shop Drawings and submit, as required, new Samples for review and approval. Contractor shall direct specific attention in writing to revisions other than the corrections called for by Engineer on previous submittals.

6.18 *Continuing the Work*

- A. Contractor shall carry on the Work and adhere to the Progress Schedule during all disputes or disagreements with Owner. No Work shall be delayed or postponed pending resolution of any disputes or disagreements, except as permitted by Paragraph 15.04 or as Owner and Contractor may otherwise agree in writing.

6.19 *Contractor's General Warranty and Guarantee*

- A. Contractor warrants and guarantees to Owner that all Work will be in accordance with the Contract Documents and will not be defective. Engineer and its officers, directors, members, partners, employees, agents, consultants, and subcontractors shall be entitled to rely on representation of Contractor's warranty and guarantee.
- B. Contractor's warranty and guarantee hereunder excludes defects or damage caused by:

1. abuse, modification, or improper maintenance or operation by persons other than Contractor, Subcontractors, Suppliers, or any other individual or entity for whom Contractor is responsible; or
  2. normal wear and tear under normal usage.
- C. Contractor's obligation to perform and complete the Work in accordance with the Contract Documents shall be absolute. None of the following will constitute an acceptance of Work that is not in accordance with the Contract Documents or a release of Contractor's obligation to perform the Work in accordance with the Contract Documents:
1. observations by Engineer;
  2. recommendation by Engineer or payment by Owner of any progress or final payment;
  3. the issuance of a certificate of Substantial Completion by Engineer or any payment related thereto by Owner;
  4. use or occupancy of the Work or any part thereof by Owner;
  5. any review and approval of a Shop Drawing or Sample submittal or the issuance of a notice of acceptability by Engineer;
  6. any inspection, test, or approval by others; or
  7. any correction of defective Work by Owner.

#### 6.20 *Indemnification*

- A. To the fullest extent permitted by Laws and Regulations, Contractor shall indemnify and hold harmless Owner and Engineer, and the officers, directors, members, partners, employees, agents, consultants and subcontractors of each and any of them from and against all claims, costs, losses, and damages (including but not limited to all fees and charges of engineers, architects, attorneys, and other professionals and all court or arbitration or other dispute resolution costs) arising out of or relating to the performance of the Work, provided that any such claim, cost, loss, or damage is attributable to bodily injury, sickness, disease, or death, or to injury to or destruction of tangible property (other than the Work itself), including the loss of use resulting therefrom but only to the extent caused by any negligent act or omission of Contractor, any Subcontractor, any Supplier, or any individual or entity directly or indirectly employed by any of them to perform any of the Work or anyone for whose acts any of them may be liable .
- B. In any and all claims against Owner or Engineer or any of their officers, directors, members, partners, employees, agents, consultants, or subcontractors by any employee (or the survivor or personal representative of such employee) of Contractor, any Subcontractor, any Supplier, or any individual or entity directly or indirectly employed by any of them to perform any of the Work, or anyone for whose acts any of them may be liable, the indemnification obligation under Paragraph 6.20.A shall not be limited in any way by any limitation on the amount or type of damages, compensation, or benefits payable by or for Contractor or any such Subcontractor,

Supplier, or other individual or entity under workers' compensation acts, disability benefit acts, or other employee benefit acts.

- C. The indemnification obligations of Contractor under Paragraph 6.20.A shall not extend to the liability of Engineer and Engineer's officers, directors, members, partners, employees, agents, consultants and subcontractors arising out of:
  - 1. the preparation or approval of, or the failure to prepare or approve maps, Drawings, opinions, reports, surveys, Change Orders, designs, or Specifications; or
  - 2. giving directions or instructions, or failing to give them, if that is the primary cause of the injury or damage.

#### 6.21 *Delegation of Professional Design Services*

- A. Contractor will not be required to provide professional design services unless such services are specifically required by the Contract Documents for a portion of the Work or unless such services are required to carry out Contractor's responsibilities for construction means, methods, techniques, sequences and procedures. Contractor shall not be required to provide professional services in violation of applicable law.
- B. If professional design services or certifications by a design professional related to systems, materials or equipment are specifically required of Contractor by the Contract Documents, Owner and Engineer will specify all performance and design criteria that such services must satisfy. Contractor shall cause such services or certifications to be provided by a properly licensed professional, whose signature and seal shall appear on all drawings, calculations, specifications, certifications, Shop Drawings and other submittals prepared by such professional. Shop Drawings and other submittals related to the Work designed or certified by such professional, if prepared by others, shall bear such professional's written approval when submitted to Engineer.
- C. Owner and Engineer shall be entitled to rely upon the adequacy, accuracy and completeness of the services, certifications or approvals performed by such design professionals, provided Owner and Engineer have specified to Contractor all performance and design criteria that such services must satisfy.
- D. Pursuant to this Paragraph 6.21, Engineer's review and approval of design calculations and design drawings will be only for the limited purpose of checking for conformance with performance and design criteria given and the design concept expressed in the Contract Documents. Engineer's review and approval of Shop Drawings and other submittals (except design calculations and design drawings) will be only for the purpose stated in Paragraph 6.17.D.1.
- E. Contractor shall not be responsible for the adequacy of the performance or design criteria required by the Contract Documents.

## ARTICLE 7 – OTHER WORK AT THE SITE

### 7.01 *Related Work at Site*

- A. Owner may perform other work related to the Project at the Site with Owner's employees, or through other direct contracts therefor, or have other work performed by utility owners. If such other work is not noted in the Contract Documents, then:
1. written notice thereof will be given to Contractor prior to starting any such other work; and
  2. if Owner and Contractor are unable to agree on entitlement to or on the amount or extent, if any, of any adjustment in the Contract Price or Contract Times that should be allowed as a result of such other work, a Claim may be made therefor as provided in Paragraph 10.05.
- B. Contractor shall afford each other contractor who is a party to such a direct contract, each utility owner, and Owner, if Owner is performing other work with Owner's employees, proper and safe access to the Site, provide a reasonable opportunity for the introduction and storage of materials and equipment and the execution of such other work, and properly coordinate the Work with theirs. Contractor shall do all cutting, fitting, and patching of the Work that may be required to properly connect or otherwise make its several parts come together and properly integrate with such other work. Contractor shall not endanger any work of others by cutting, excavating, or otherwise altering such work; provided, however, that Contractor may cut or alter others' work with the written consent of Engineer and the others whose work will be affected. The duties and responsibilities of Contractor under this Paragraph are for the benefit of such utility owners and other contractors to the extent that there are comparable provisions for the benefit of Contractor in said direct contracts between Owner and such utility owners and other contractors.
- C. If the proper execution or results of any part of Contractor's Work depends upon work performed by others under this Article 7, Contractor shall inspect such other work and promptly report to Engineer in writing any delays, defects, or deficiencies in such other work that render it unavailable or unsuitable for the proper execution and results of Contractor's Work. Contractor's failure to so report will constitute an acceptance of such other work as fit and proper for integration with Contractor's Work except for latent defects and deficiencies in such other work.

### 7.02 *Coordination*

- A. If Owner intends to contract with others for the performance of other work on the Project at the Site, the following will be set forth in Supplementary Conditions:
1. the individual or entity who will have authority and responsibility for coordination of the activities among the various contractors will be identified;
  2. the specific matters to be covered by such authority and responsibility will be itemized; and
  3. the extent of such authority and responsibilities will be provided.
- B. Unless otherwise provided in the Supplementary Conditions, Owner shall have sole authority and responsibility for such coordination.

### 7.03 *Legal Relationships*

- A. Paragraphs 7.01.A and 7.02 are not applicable for utilities not under the control of Owner.
- B. Each other direct contract of Owner under Paragraph 7.01.A shall provide that the other contractor is liable to Owner and Contractor for the reasonable direct delay and disruption costs incurred by Contractor as a result of the other contractor's wrongful actions or inactions.
- C. Contractor shall be liable to Owner and any other contractor under direct contract to Owner for the reasonable direct delay and disruption costs incurred by such other contractor as a result of Contractor's wrongful action or inactions.

## **ARTICLE 8 – OWNER'S RESPONSIBILITIES**

### 8.01 *Communications to Contractor*

- A. Except as otherwise provided in these General Conditions, Owner shall issue all communications to Contractor through Engineer.

### 8.02 *Replacement of Engineer*

- A. In case of termination of the employment of Engineer, Owner shall appoint an engineer to whom Contractor makes no reasonable objection, whose status under the Contract Documents shall be that of the former Engineer.

### 8.03 *Furnish Data*

- A. Owner shall promptly furnish the data required of Owner under the Contract Documents.

### 8.04 *Pay When Due*

- A. Owner shall make payments to Contractor when they are due as provided in Paragraphs 14.02.C and 14.07.C.

### 8.05 *Lands and Easements; Reports and Tests*

- A. Owner's duties with respect to providing lands and easements and providing engineering surveys to establish reference points are set forth in Paragraphs 4.01 and 4.05. Paragraph 4.02 refers to Owner's identifying and making available to Contractor copies of reports of explorations and tests of subsurface conditions and drawings of physical conditions relating to existing surface or subsurface structures at the Site.

### 8.06 *Insurance*

- A. Owner's responsibilities, if any, with respect to purchasing and maintaining liability and property insurance are set forth in Article 5.

### 8.07 *Change Orders*

- A. Owner is obligated to execute Change Orders as indicated in Paragraph 10.03.



8.08 *Inspections, Tests, and Approvals*

- A. Owner's responsibility with respect to certain inspections, tests, and approvals is set forth in Paragraph 13.03.B.

8.09 *Limitations on Owner's Responsibilities*

- A. The Owner shall not supervise, direct, or have control or authority over, nor be responsible for, Contractor's means, methods, techniques, sequences, or procedures of construction, or the safety precautions and programs incident thereto, or for any failure of Contractor to comply with Laws and Regulations applicable to the performance of the Work. Owner will not be responsible for Contractor's failure to perform the Work in accordance with the Contract Documents.

8.10 *Undisclosed Hazardous Environmental Condition*

- A. Owner's responsibility in respect to an undisclosed Hazardous Environmental Condition is set forth in Paragraph 4.06.

8.11 *Evidence of Financial Arrangements*

- A. Upon request of Contractor, Owner shall furnish Contractor reasonable evidence that financial arrangements have been made to satisfy Owner's obligations under the Contract Documents.

8.12 *Compliance with Safety Program*

- A. While at the Site, Owner's employees and representatives shall comply with the specific applicable requirements of Contractor's safety programs of which Owner has been informed pursuant to Paragraph 6.13.D.

**ARTICLE 9 – ENGINEER'S STATUS DURING CONSTRUCTION**

9.01 *Owner's Representative*

- A. Engineer will be Owner's representative during the construction period. The duties and responsibilities and the limitations of authority of Engineer as Owner's representative during construction are set forth in the Contract Documents.

9.02 *Visits to Site*

- A. Engineer will make visits to the Site at intervals appropriate to the various stages of construction as Engineer deems necessary in order to observe as an experienced and qualified design professional the progress that has been made and the quality of the various aspects of Contractor's executed Work. Based on information obtained during such visits and observations, Engineer, for the benefit of Owner, will determine, in general, if the Work is proceeding in accordance with the Contract Documents. Engineer will not be required to make exhaustive or continuous inspections on the Site to check the quality or quantity of the Work. Engineer's efforts will be directed toward providing for Owner a greater degree of confidence that the completed Work will conform generally to the Contract Documents. On the basis of such visits

and observations, Engineer will keep Owner informed of the progress of the Work and will endeavor to guard Owner against defective Work.

- B. Engineer's visits and observations are subject to all the limitations on Engineer's authority and responsibility set forth in Paragraph 9.09. Particularly, but without limitation, during or as a result of Engineer's visits or observations of Contractor's Work, Engineer will not supervise, direct, control, or have authority over or be responsible for Contractor's means, methods, techniques, sequences, or procedures of construction, or the safety precautions and programs incident thereto, or for any failure of Contractor to comply with Laws and Regulations applicable to the performance of the Work.

#### 9.03 *Project Representative*

- A. If Owner and Engineer agree, Engineer will furnish a Resident Project Representative to assist Engineer in providing more extensive observation of the Work. The authority and responsibilities of any such Resident Project Representative and assistants will be as provided in the Supplementary Conditions, and limitations on the responsibilities thereof will be as provided in Paragraph 9.09. If Owner designates another representative or agent to represent Owner at the Site who is not Engineer's consultant, agent or employee, the responsibilities and authority and limitations thereon of such other individual or entity will be as provided in the Supplementary Conditions.

#### 9.04 *Authorized Variations in Work*

- A. Engineer may authorize minor variations in the Work from the requirements of the Contract Documents which do not involve an adjustment in the Contract Price or the Contract Times and are compatible with the design concept of the completed Project as a functioning whole as indicated by the Contract Documents. These may be accomplished by a Field Order and will be binding on Owner and also on Contractor, who shall perform the Work involved promptly. If Owner or Contractor believes that a Field Order justifies an adjustment in the Contract Price or Contract Times, or both, and the parties are unable to agree on entitlement to or on the amount or extent, if any, of any such adjustment, a Claim may be made therefor as provided in Paragraph 10.05.

#### 9.05 *Rejecting Defective Work*

- A. Engineer will have authority to reject Work which Engineer believes to be defective, or that Engineer believes will not produce a completed Project that conforms to the Contract Documents or that will prejudice the integrity of the design concept of the completed Project as a functioning whole as indicated by the Contract Documents. Engineer will also have authority to require special inspection or testing of the Work as provided in Paragraph 13.04, whether or not the Work is fabricated, installed, or completed.

#### 9.06 *Shop Drawings, Change Orders and Payments*

- A. In connection with Engineer's authority, and limitations thereof, as to Shop Drawings and Samples, see Paragraph 6.17.

- B. In connection with Engineer's authority, and limitations thereof, as to design calculations and design drawings submitted in response to a delegation of professional design services, if any, see Paragraph 6.21.
- C. In connection with Engineer's authority as to Change Orders, see Articles 10, 11, and 12.
- D. In connection with Engineer's authority as to Applications for Payment, see Article 14.

9.07 *Determinations for Unit Price Work*

- A. Engineer will determine the actual quantities and classifications of Unit Price Work performed by Contractor. Engineer will review with Contractor the Engineer's preliminary determinations on such matters before rendering a written decision thereon (by recommendation of an Application for Payment or otherwise). Engineer's written decision thereon will be final and binding (except as modified by Engineer to reflect changed factual conditions or more accurate data) upon Owner and Contractor, subject to the provisions of Paragraph 10.05.

9.08 *Decisions on Requirements of Contract Documents and Acceptability of Work*

- A. Engineer will be the initial interpreter of the requirements of the Contract Documents and judge of the acceptability of the Work thereunder. All matters in question and other matters between Owner and Contractor arising prior to the date final payment is due relating to the acceptability of the Work, and the interpretation of the requirements of the Contract Documents pertaining to the performance of the Work, will be referred initially to Engineer in writing within 30 days of the event giving rise to the question.
- B. Engineer will, with reasonable promptness, render a written decision on the issue referred. If Owner or Contractor believes that any such decision entitles them to an adjustment in the Contract Price or Contract Times or both, a Claim may be made under Paragraph 10.05. The date of Engineer's decision shall be the date of the event giving rise to the issues referenced for the purposes of Paragraph 10.05.B.
- C. Engineer's written decision on the issue referred will be final and binding on Owner and Contractor, subject to the provisions of Paragraph 10.05.
- D. When functioning as interpreter and judge under this Paragraph 9.08, Engineer will not show partiality to Owner or Contractor and will not be liable in connection with any interpretation or decision rendered in good faith in such capacity.

9.09 *Limitations on Engineer's Authority and Responsibilities*

- A. Neither Engineer's authority or responsibility under this Article 9 or under any other provision of the Contract Documents nor any decision made by Engineer in good faith either to exercise or not exercise such authority or responsibility or the undertaking, exercise, or performance of any authority or responsibility by Engineer shall create, impose, or give rise to any duty in contract, tort, or otherwise owed by Engineer to Contractor, any Subcontractor, any Supplier, any other individual or entity, or to any surety for or employee or agent of any of them.

- B. Engineer will not supervise, direct, control, or have authority over or be responsible for Contractor's means, methods, techniques, sequences, or procedures of construction, or the safety precautions and programs incident thereto, or for any failure of Contractor to comply with Laws and Regulations applicable to the performance of the Work. Engineer will not be responsible for Contractor's failure to perform the Work in accordance with the Contract Documents.
- C. Engineer will not be responsible for the acts or omissions of Contractor or of any Subcontractor, any Supplier, or of any other individual or entity performing any of the Work.
- D. Engineer's review of the final Application for Payment and accompanying documentation and all maintenance and operating instructions, schedules, guarantees, bonds, certificates of inspection, tests and approvals, and other documentation required to be delivered by Paragraph 14.07.A will only be to determine generally that their content complies with the requirements of, and in the case of certificates of inspections, tests, and approvals that the results certified indicate compliance with, the Contract Documents.
- E. The limitations upon authority and responsibility set forth in this Paragraph 9.09 shall also apply to the Resident Project Representative, if any, and assistants, if any.

9.10 *Compliance with Safety Program*

- A. While at the Site, Engineer's employees and representatives shall comply with the specific applicable requirements of Contractor's safety programs of which Engineer has been informed pursuant to Paragraph 6.13.D.

**ARTICLE 10 – CHANGES IN THE WORK; CLAIMS**

10.01 *Authorized Changes in the Work*

- A. Without invalidating the Contract and without notice to any surety, Owner may, at any time or from time to time, order additions, deletions, or revisions in the Work by a Change Order, or a Work Change Directive. Upon receipt of any such document, Contractor shall promptly proceed with the Work involved which will be performed under the applicable conditions of the Contract Documents (except as otherwise specifically provided).
- B. If Owner and Contractor are unable to agree on entitlement to, or on the amount or extent, if any, of an adjustment in the Contract Price or Contract Times, or both, that should be allowed as a result of a Work Change Directive, a Claim may be made therefor as provided in Paragraph 10.05.

10.02 *Unauthorized Changes in the Work*

- A. Contractor shall not be entitled to an increase in the Contract Price or an extension of the Contract Times with respect to any work performed that is not required by the Contract Documents as amended, modified, or supplemented as provided in Paragraph 3.04, except in the case of an emergency as provided in Paragraph 6.16 or in the case of uncovering Work as provided in Paragraph 13.04.D.

### 10.03 *Execution of Change Orders*

- A. Owner and Contractor shall execute appropriate Change Orders recommended by Engineer covering:
1. changes in the Work which are: (i) ordered by Owner pursuant to Paragraph 10.01.A, (ii) required because of acceptance of defective Work under Paragraph 13.08.A or Owner's correction of defective Work under Paragraph 13.09, or (iii) agreed to by the parties;
  2. changes in the Contract Price or Contract Times which are agreed to by the parties, including any undisputed sum or amount of time for Work actually performed in accordance with a Work Change Directive; and
  3. changes in the Contract Price or Contract Times which embody the substance of any written decision rendered by Engineer pursuant to Paragraph 10.05; provided that, in lieu of executing any such Change Order, an appeal may be taken from any such decision in accordance with the provisions of the Contract Documents and applicable Laws and Regulations, but during any such appeal, Contractor shall carry on the Work and adhere to the Progress Schedule as provided in Paragraph 6.18.A.

### 10.04 *Notification to Surety*

- A. If the provisions of any bond require notice to be given to a surety of any change affecting the general scope of the Work or the provisions of the Contract Documents (including, but not limited to, Contract Price or Contract Times), the giving of any such notice will be Contractor's responsibility. The amount of each applicable bond will be adjusted to reflect the effect of any such change.

### 10.05 *Claims*

- A. *Engineer's Decision Required:* All Claims, except those waived pursuant to Paragraph 14.09, shall be referred to the Engineer for decision. A decision by Engineer shall be required as a condition precedent to any exercise by Owner or Contractor of any rights or remedies either may otherwise have under the Contract Documents or by Laws and Regulations in respect of such Claims.
- B. *Notice:* Written notice stating the general nature of each Claim shall be delivered by the claimant to Engineer and the other party to the Contract promptly (but in no event later than 30 days) after the start of the event giving rise thereto. The responsibility to substantiate a Claim shall rest with the party making the Claim. Notice of the amount or extent of the Claim, with supporting data shall be delivered to the Engineer and the other party to the Contract within 60 days after the start of such event (unless Engineer allows additional time for claimant to submit additional or more accurate data in support of such Claim). A Claim for an adjustment in Contract Price shall be prepared in accordance with the provisions of Paragraph 12.01.B. A Claim for an adjustment in Contract Times shall be prepared in accordance with the provisions of Paragraph 12.02.B. Each Claim shall be accompanied by claimant's written statement that the adjustment claimed is the entire adjustment to which the claimant believes it is entitled as a result of said event. The

opposing party shall submit any response to Engineer and the claimant within 30 days after receipt of the claimant's last submittal (unless Engineer allows additional time).

- C. *Engineer's Action:* Engineer will review each Claim and, within 30 days after receipt of the last submittal of the claimant or the last submittal of the opposing party, if any, take one of the following actions in writing:
1. deny the Claim in whole or in part;
  2. approve the Claim; or
  3. notify the parties that the Engineer is unable to resolve the Claim if, in the Engineer's sole discretion, it would be inappropriate for the Engineer to do so. For purposes of further resolution of the Claim, such notice shall be deemed a denial.
- D. In the event that Engineer does not take action on a Claim within said 30 days, the Claim shall be deemed denied.
- E. Engineer's written action under Paragraph 10.05.C or denial pursuant to Paragraphs 10.05.C.3 or 10.05.D will be final and binding upon Owner and Contractor, unless Owner or Contractor invoke the dispute resolution procedure set forth in Article 16 within 30 days of such action or denial.
- F. No Claim for an adjustment in Contract Price or Contract Times will be valid if not submitted in accordance with this Paragraph 10.05.

## **ARTICLE 11 – COST OF THE WORK; ALLOWANCES; UNIT PRICE WORK**

### *11.01 Cost of the Work*

- A. *Costs Included:* The term Cost of the Work means the sum of all costs, except those excluded in Paragraph 11.01.B, necessarily incurred and paid by Contractor in the proper performance of the Work. When the value of any Work covered by a Change Order or when a Claim for an adjustment in Contract Price is determined on the basis of Cost of the Work, the costs to be reimbursed to Contractor will be only those additional or incremental costs required because of the change in the Work or because of the event giving rise to the Claim. Except as otherwise may be agreed to in writing by Owner, such costs shall be in amounts no higher than those prevailing in the locality of the Project, shall not include any of the costs itemized in Paragraph 11.01.B, and shall include only the following items:
1. Payroll costs for employees in the direct employ of Contractor in the performance of the Work under schedules of job classifications agreed upon by Owner and Contractor. Such employees shall include, without limitation, superintendents, foremen, and other personnel employed full time on the Work. Payroll costs for employees not employed full time on the Work shall be apportioned on the basis of their time spent on the Work. Payroll costs shall include, but not be limited to, salaries and wages plus the cost of fringe benefits, which shall include social security contributions, unemployment, excise, and payroll taxes, workers' compensation, health and retirement benefits, bonuses, sick leave, vacation and holiday pay applicable thereto. The expenses of performing Work outside of regular working hours, on

Saturday, Sunday, or legal holidays, shall be included in the above to the extent authorized by Owner.

2. Cost of all materials and equipment furnished and incorporated in the Work, including costs of transportation and storage thereof, and Suppliers' field services required in connection therewith. All cash discounts shall accrue to Contractor unless Owner deposits funds with Contractor with which to make payments, in which case the cash discounts shall accrue to Owner. All trade discounts, rebates and refunds and returns from sale of surplus materials and equipment shall accrue to Owner, and Contractor shall make provisions so that they may be obtained.
3. Payments made by Contractor to Subcontractors for Work performed by Subcontractors. If required by Owner, Contractor shall obtain competitive bids from subcontractors acceptable to Owner and Contractor and shall deliver such bids to Owner, who will then determine, with the advice of Engineer, which bids, if any, will be acceptable. If any subcontract provides that the Subcontractor is to be paid on the basis of Cost of the Work plus a fee, the Subcontractor's Cost of the Work and fee shall be determined in the same manner as Contractor's Cost of the Work and fee as provided in this Paragraph 11.01.
4. Costs of special consultants (including but not limited to engineers, architects, testing laboratories, surveyors, attorneys, and accountants) employed for services specifically related to the Work.
5. Supplemental costs including the following:
  - a. The proportion of necessary transportation, travel, and subsistence expenses of Contractor's employees incurred in discharge of duties connected with the Work.
  - b. Cost, including transportation and maintenance, of all materials, supplies, equipment, machinery, appliances, office, and temporary facilities at the Site, and hand tools not owned by the workers, which are consumed in the performance of the Work, and cost, less market value, of such items used but not consumed which remain the property of Contractor.
  - c. Rentals of all construction equipment and machinery, and the parts thereof whether rented from Contractor or others in accordance with rental agreements approved by Owner with the advice of Engineer, and the costs of transportation, loading, unloading, assembly, dismantling, and removal thereof. All such costs shall be in accordance with the terms of said rental agreements. The rental of any such equipment, machinery, or parts shall cease when the use thereof is no longer necessary for the Work.
  - d. Sales, consumer, use, and other similar taxes related to the Work, and for which Contractor is liable, as imposed by Laws and Regulations.
  - e. Deposits lost for causes other than negligence of Contractor, any Subcontractor, or anyone directly or indirectly employed by any of them or for whose acts any of them may be liable, and royalty payments and fees for permits and licenses.

- f. Losses and damages (and related expenses) caused by damage to the Work, not compensated by insurance or otherwise, sustained by Contractor in connection with the performance of the Work (except losses and damages within the deductible amounts of property insurance established in accordance with Paragraph 5.06.D), provided such losses and damages have resulted from causes other than the negligence of Contractor, any Subcontractor, or anyone directly or indirectly employed by any of them or for whose acts any of them may be liable. Such losses shall include settlements made with the written consent and approval of Owner. No such losses, damages, and expenses shall be included in the Cost of the Work for the purpose of determining Contractor's fee.
- g. The cost of utilities, fuel, and sanitary facilities at the Site.
- h. Minor expenses such as telegrams, long distance telephone calls, telephone service at the Site, express and courier services, and similar petty cash items in connection with the Work.
- i. The costs of premiums for all bonds and insurance Contractor is required by the Contract Documents to purchase and maintain.

B. *Costs Excluded:* The term Cost of the Work shall not include any of the following items:

- 1. Payroll costs and other compensation of Contractor's officers, executives, principals (of partnerships and sole proprietorships), general managers, safety managers, engineers, architects, estimators, attorneys, auditors, accountants, purchasing and contracting agents, expeditors, timekeepers, clerks, and other personnel employed by Contractor, whether at the Site or in Contractor's principal or branch office for general administration of the Work and not specifically included in the agreed upon schedule of job classifications referred to in Paragraph 11.01.A.1 or specifically covered by Paragraph 11.01.A.4, all of which are to be considered administrative costs covered by the Contractor's fee.
- 2. Expenses of Contractor's principal and branch offices other than Contractor's office at the Site.
- 3. Any part of Contractor's capital expenses, including interest on Contractor's capital employed for the Work and charges against Contractor for delinquent payments.
- 4. Costs due to the negligence of Contractor, any Subcontractor, or anyone directly or indirectly employed by any of them or for whose acts any of them may be liable, including but not limited to, the correction of defective Work, disposal of materials or equipment wrongly supplied, and making good any damage to property.
- 5. Other overhead or general expense costs of any kind and the costs of any item not specifically and expressly included in Paragraphs 11.01.A.

C. *Contractor's Fee:* When all the Work is performed on the basis of cost-plus, Contractor's fee shall be determined as set forth in the Agreement. When the value of any Work covered by a Change Order or when a Claim for an adjustment in Contract Price is determined on the basis of Cost of the Work, Contractor's fee shall be determined as set forth in Paragraph 12.01.C.



- D. *Documentation:* Whenever the Cost of the Work for any purpose is to be determined pursuant to Paragraphs 11.01.A and 11.01.B, Contractor will establish and maintain records thereof in accordance with generally accepted accounting practices and submit in a form acceptable to Engineer an itemized cost breakdown together with supporting data.

#### 11.02 *Allowances*

- A. It is understood that Contractor has included in the Contract Price all allowances so named in the Contract Documents and shall cause the Work so covered to be performed for such sums and by such persons or entities as may be acceptable to Owner and Engineer.

B. *Cash Allowances:*

1. Contractor agrees that:

- a. the cash allowances include the cost to Contractor (less any applicable trade discounts) of materials and equipment required by the allowances to be delivered at the Site, and all applicable taxes; and
- b. Contractor's costs for unloading and handling on the Site, labor, installation, overhead, profit, and other expenses contemplated for the cash allowances have been included in the Contract Price and not in the allowances, and no demand for additional payment on account of any of the foregoing will be valid.

C. *Contingency Allowance:*

1. Contractor agrees that a contingency allowance, if any, is for the sole use of Owner to cover unanticipated costs.

- D. Prior to final payment, an appropriate Change Order will be issued as recommended by Engineer to reflect actual amounts due Contractor on account of Work covered by allowances, and the Contract Price shall be correspondingly adjusted.

#### 11.03 *Unit Price Work*

- A. Where the Contract Documents provide that all or part of the Work is to be Unit Price Work, initially the Contract Price will be deemed to include for all Unit Price Work an amount equal to the sum of the unit price for each separately identified item of Unit Price Work times the estimated quantity of each item as indicated in the Agreement.
- B. The estimated quantities of items of Unit Price Work are not guaranteed and are solely for the purpose of comparison of Bids and determining an initial Contract Price. Determinations of the actual quantities and classifications of Unit Price Work performed by Contractor will be made by Engineer subject to the provisions of Paragraph 9.07.
- C. Each unit price will be deemed to include an amount considered by Contractor to be adequate to cover Contractor's overhead and profit for each separately identified item.

- D. Owner or Contractor may make a Claim for an adjustment in the Contract Price in accordance with Paragraph 10.05 if:
1. the quantity of any item of Unit Price Work performed by Contractor differs materially and significantly from the estimated quantity of such item indicated in the Agreement; and
  2. there is no corresponding adjustment with respect to any other item of Work; and
  3. Contractor believes that Contractor is entitled to an increase in Contract Price as a result of having incurred additional expense or Owner believes that Owner is entitled to a decrease in Contract Price and the parties are unable to agree as to the amount of any such increase or decrease.

## **ARTICLE 12 – CHANGE OF CONTRACT PRICE; CHANGE OF CONTRACT TIMES**

### *12.01 Change of Contract Price*

- A. The Contract Price may only be changed by a Change Order. Any Claim for an adjustment in the Contract Price shall be based on written notice submitted by the party making the Claim to the Engineer and the other party to the Contract in accordance with the provisions of Paragraph 10.05.
- B. The value of any Work covered by a Change Order or of any Claim for an adjustment in the Contract Price will be determined as follows:
1. where the Work involved is covered by unit prices contained in the Contract Documents, by application of such unit prices to the quantities of the items involved (subject to the provisions of Paragraph 11.03); or
  2. where the Work involved is not covered by unit prices contained in the Contract Documents, by a mutually agreed lump sum (which may include an allowance for overhead and profit not necessarily in accordance with Paragraph 12.01.C.2); or
  3. where the Work involved is not covered by unit prices contained in the Contract Documents and agreement to a lump sum is not reached under Paragraph 12.01.B.2, on the basis of the Cost of the Work (determined as provided in Paragraph 11.01) plus a Contractor's fee for overhead and profit (determined as provided in Paragraph 12.01.C).
- C. *Contractor's Fee:* The Contractor's fee for overhead and profit shall be determined as follows:
1. a mutually acceptable fixed fee; or
  2. if a fixed fee is not agreed upon, then a fee based on the following percentages of the various portions of the Cost of the Work:
    - a. for costs incurred under Paragraphs 11.01.A.1 and 11.01.A.2, the Contractor's fee shall be 15 percent;
    - b. for costs incurred under Paragraph 11.01.A.3, the Contractor's fee shall be five percent;

- c. where one or more tiers of subcontracts are on the basis of Cost of the Work plus a fee and no fixed fee is agreed upon, the intent of Paragraphs 12.01.C.2.a and 12.01.C.2.b is that the Subcontractor who actually performs the Work, at whatever tier, will be paid a fee of 15 percent of the costs incurred by such Subcontractor under Paragraphs 11.01.A.1 and 11.01.A.2 and that any higher tier Subcontractor and Contractor will each be paid a fee of five percent of the amount paid to the next lower tier Subcontractor;
- d. no fee shall be payable on the basis of costs itemized under Paragraphs 11.01.A.4, 11.01.A.5, and 11.01.B;
- e. the amount of credit to be allowed by Contractor to Owner for any change which results in a net decrease in cost will be the amount of the actual net decrease in cost plus a deduction in Contractor's fee by an amount equal to five percent of such net decrease; and
- f. when both additions and credits are involved in any one change, the adjustment in Contractor's fee shall be computed on the basis of the net change in accordance with Paragraphs 12.01.C.2.a through 12.01.C.2.e, inclusive.

#### 12.02 *Change of Contract Times*

- A. The Contract Times may only be changed by a Change Order. Any Claim for an adjustment in the Contract Times shall be based on written notice submitted by the party making the Claim to the Engineer and the other party to the Contract in accordance with the provisions of Paragraph 10.05.
- B. Any adjustment of the Contract Times covered by a Change Order or any Claim for an adjustment in the Contract Times will be determined in accordance with the provisions of this Article 12.

#### 12.03 *Delays*

- A. Where Contractor is prevented from completing any part of the Work within the Contract Times due to delay beyond the control of Contractor, the Contract Times will be extended in an amount equal to the time lost due to such delay if a Claim is made therefor as provided in Paragraph 12.02.A. Delays beyond the control of Contractor shall include, but not be limited to, acts or neglect by Owner, acts or neglect of utility owners or other contractors performing other work as contemplated by Article 7, fires, floods, epidemics, abnormal weather conditions, or acts of God.
- B. If Owner, Engineer, or other contractors or utility owners performing other work for Owner as contemplated by Article 7, or anyone for whom Owner is responsible, delays, disrupts, or interferes with the performance or progress of the Work, then Contractor shall be entitled to an equitable adjustment in the Contract Price or the Contract Times, or both. Contractor's entitlement to an adjustment of the Contract Times is conditioned on such adjustment being essential to Contractor's ability to complete the Work within the Contract Times.
- C. If Contractor is delayed in the performance or progress of the Work by fire, flood, epidemic, abnormal weather conditions, acts of God, acts or failures to act of utility owners not under the

control of Owner, or other causes not the fault of and beyond control of Owner and Contractor, then Contractor shall be entitled to an equitable adjustment in Contract Times, if such adjustment is essential to Contractor's ability to complete the Work within the Contract Times. Such an adjustment shall be Contractor's sole and exclusive remedy for the delays described in this Paragraph 12.03.C.

- D. Owner, Engineer, and their officers, directors, members, partners, employees, agents, consultants, or subcontractors shall not be liable to Contractor for any claims, costs, losses, or damages (including but not limited to all fees and charges of engineers, architects, attorneys, and other professionals and all court or arbitration or other dispute resolution costs) sustained by Contractor on or in connection with any other project or anticipated project.
- E. Contractor shall not be entitled to an adjustment in Contract Price or Contract Times for delays within the control of Contractor. Delays attributable to and within the control of a Subcontractor or Supplier shall be deemed to be delays within the control of Contractor.

## **ARTICLE 13 – TESTS AND INSPECTIONS; CORRECTION, REMOVAL OR ACCEPTANCE OF DEFECTIVE WORK**

### *13.01 Notice of Defects*

- A. Prompt notice of all defective Work of which Owner or Engineer has actual knowledge will be given to Contractor. Defective Work may be rejected, corrected, or accepted as provided in this Article 13.

### *13.02 Access to Work*

- A. Owner, Engineer, their consultants and other representatives and personnel of Owner, independent testing laboratories, and governmental agencies with jurisdictional interests will have access to the Site and the Work at reasonable times for their observation, inspection, and testing. Contractor shall provide them proper and safe conditions for such access and advise them of Contractor's safety procedures and programs so that they may comply therewith as applicable.

### *13.03 Tests and Inspections*

- A. Contractor shall give Engineer timely notice of readiness of the Work for all required inspections, tests, or approvals and shall cooperate with inspection and testing personnel to facilitate required inspections or tests.
- B. Owner shall employ and pay for the services of an independent testing laboratory to perform all inspections, tests, or approvals required by the Contract Documents except:
  - 1. for inspections, tests, or approvals covered by Paragraphs 13.03.C and 13.03.D below;
  - 2. that costs incurred in connection with tests or inspections conducted pursuant to Paragraph 13.04.B shall be paid as provided in Paragraph 13.04.C; and
  - 3. as otherwise specifically provided in the Contract Documents.

- C. If Laws or Regulations of any public body having jurisdiction require any Work (or part thereof) specifically to be inspected, tested, or approved by an employee or other representative of such public body, Contractor shall assume full responsibility for arranging and obtaining such inspections, tests, or approvals, pay all costs in connection therewith, and furnish Engineer the required certificates of inspection or approval.
- D. Contractor shall be responsible for arranging and obtaining and shall pay all costs in connection with any inspections, tests, or approvals required for Owner's and Engineer's acceptance of materials or equipment to be incorporated in the Work; or acceptance of materials, mix designs, or equipment submitted for approval prior to Contractor's purchase thereof for incorporation in the Work. Such inspections, tests, or approvals shall be performed by organizations acceptable to Owner and Engineer.
- E. If any Work (or the work of others) that is to be inspected, tested, or approved is covered by Contractor without written concurrence of Engineer, Contractor shall, if requested by Engineer, uncover such Work for observation.
- F. Uncovering Work as provided in Paragraph 13.03.E shall be at Contractor's expense unless Contractor has given Engineer timely notice of Contractor's intention to cover the same and Engineer has not acted with reasonable promptness in response to such notice.

#### 13.04 *Uncovering Work*

- A. If any Work is covered contrary to the written request of Engineer, it must, if requested by Engineer, be uncovered for Engineer's observation and replaced at Contractor's expense.
- B. If Engineer considers it necessary or advisable that covered Work be observed by Engineer or inspected or tested by others, Contractor, at Engineer's request, shall uncover, expose, or otherwise make available for observation, inspection, or testing as Engineer may require, that portion of the Work in question, furnishing all necessary labor, material, and equipment.
- C. If it is found that the uncovered Work is defective, Contractor shall pay all claims, costs, losses, and damages (including but not limited to all fees and charges of engineers, architects, attorneys, and other professionals and all court or arbitration or other dispute resolution costs) arising out of or relating to such uncovering, exposure, observation, inspection, and testing, and of satisfactory replacement or reconstruction (including but not limited to all costs of repair or replacement of work of others); and Owner shall be entitled to an appropriate decrease in the Contract Price. If the parties are unable to agree as to the amount thereof, Owner may make a Claim therefor as provided in Paragraph 10.05.
- D. If the uncovered Work is not found to be defective, Contractor shall be allowed an increase in the Contract Price or an extension of the Contract Times, or both, directly attributable to such uncovering, exposure, observation, inspection, testing, replacement, and reconstruction. If the parties are unable to agree as to the amount or extent thereof, Contractor may make a Claim therefor as provided in Paragraph 10.05.

### 13.05 *Owner May Stop the Work*

- A. If the Work is defective, or Contractor fails to supply sufficient skilled workers or suitable materials or equipment, or fails to perform the Work in such a way that the completed Work will conform to the Contract Documents, Owner may order Contractor to stop the Work, or any portion thereof, until the cause for such order has been eliminated; however, this right of Owner to stop the Work shall not give rise to any duty on the part of Owner to exercise this right for the benefit of Contractor, any Subcontractor, any Supplier, any other individual or entity, or any surety for, or employee or agent of any of them.

### 13.06 *Correction or Removal of Defective Work*

- A. Promptly after receipt of written notice, Contractor shall correct all defective Work, whether or not fabricated, installed, or completed, or, if the Work has been rejected by Engineer, remove it from the Project and replace it with Work that is not defective. Contractor shall pay all claims, costs, losses, and damages (including but not limited to all fees and charges of engineers, architects, attorneys, and other professionals and all court or arbitration or other dispute resolution costs) arising out of or relating to such correction or removal (including but not limited to all costs of repair or replacement of work of others).
- B. When correcting defective Work under the terms of this Paragraph 13.06 or Paragraph 13.07, Contractor shall take no action that would void or otherwise impair Owner's special warranty and guarantee, if any, on said Work.

### 13.07 *Correction Period*

- A. If within one year after the date of Substantial Completion (or such longer period of time as may be prescribed by the terms of any applicable special guarantee required by the Contract Documents) or by any specific provision of the Contract Documents, any Work is found to be defective, or if the repair of any damages to the land or areas made available for Contractor's use by Owner or permitted by Laws and Regulations as contemplated in Paragraph 6.11.A is found to be defective, Contractor shall promptly, without cost to Owner and in accordance with Owner's written instructions:
  - 1. repair such defective land or areas; or
  - 2. correct such defective Work; or
  - 3. if the defective Work has been rejected by Owner, remove it from the Project and replace it with Work that is not defective, and
  - 4. satisfactorily correct or repair or remove and replace any damage to other Work, to the work of others or other land or areas resulting therefrom.
- B. If Contractor does not promptly comply with the terms of Owner's written instructions, or in an emergency where delay would cause serious risk of loss or damage, Owner may have the defective Work corrected or repaired or may have the rejected Work removed and replaced. All claims, costs, losses, and damages (including but not limited to all fees and charges of engineers, architects, attorneys, and other professionals and all court or arbitration or other dispute

resolution costs) arising out of or relating to such correction or repair or such removal and replacement (including but not limited to all costs of repair or replacement of work of others) will be paid by Contractor.

- C. In special circumstances where a particular item of equipment is placed in continuous service before Substantial Completion of all the Work, the correction period for that item may start to run from an earlier date if so provided in the Specifications.
- D. Where defective Work (and damage to other Work resulting therefrom) has been corrected or removed and replaced under this Paragraph 13.07, the correction period hereunder with respect to such Work will be extended for an additional period of one year after such correction or removal and replacement has been satisfactorily completed.
- E. Contractor's obligations under this Paragraph 13.07 are in addition to any other obligation or warranty. The provisions of this Paragraph 13.07 shall not be construed as a substitute for, or a waiver of, the provisions of any applicable statute of limitation or repose.

#### 13.08 *Acceptance of Defective Work*

- A. If, instead of requiring correction or removal and replacement of defective Work, Owner (and, prior to Engineer's recommendation of final payment, Engineer) prefers to accept it, Owner may do so. Contractor shall pay all claims, costs, losses, and damages (including but not limited to all fees and charges of engineers, architects, attorneys, and other professionals and all court or arbitration or other dispute resolution costs) attributable to Owner's evaluation of and determination to accept such defective Work (such costs to be approved by Engineer as to reasonableness) and for the diminished value of the Work to the extent not otherwise paid by Contractor pursuant to this sentence. If any such acceptance occurs prior to Engineer's recommendation of final payment, a Change Order will be issued incorporating the necessary revisions in the Contract Documents with respect to the Work, and Owner shall be entitled to an appropriate decrease in the Contract Price, reflecting the diminished value of Work so accepted. If the parties are unable to agree as to the amount thereof, Owner may make a Claim therefor as provided in Paragraph 10.05. If the acceptance occurs after such recommendation, an appropriate amount will be paid by Contractor to Owner.

#### 13.09 *Owner May Correct Defective Work*

- A. If Contractor fails within a reasonable time after written notice from Engineer to correct defective Work, or to remove and replace rejected Work as required by Engineer in accordance with Paragraph 13.06.A, or if Contractor fails to perform the Work in accordance with the Contract Documents, or if Contractor fails to comply with any other provision of the Contract Documents, Owner may, after seven days written notice to Contractor, correct, or remedy any such deficiency.
- B. In exercising the rights and remedies under this Paragraph 13.09, Owner shall proceed expeditiously. In connection with such corrective or remedial action, Owner may exclude Contractor from all or part of the Site, take possession of all or part of the Work and suspend Contractor's services related thereto, take possession of Contractor's tools, appliances, construction equipment and machinery at the Site, and incorporate in the Work all materials and

equipment stored at the Site or for which Owner has paid Contractor but which are stored elsewhere. Contractor shall allow Owner, Owner's representatives, agents and employees, Owner's other contractors, and Engineer and Engineer's consultants access to the Site to enable Owner to exercise the rights and remedies under this Paragraph.

- C. All claims, costs, losses, and damages (including but not limited to all fees and charges of engineers, architects, attorneys, and other professionals and all court or arbitration or other dispute resolution costs) incurred or sustained by Owner in exercising the rights and remedies under this Paragraph 13.09 will be charged against Contractor, and a Change Order will be issued incorporating the necessary revisions in the Contract Documents with respect to the Work; and Owner shall be entitled to an appropriate decrease in the Contract Price. If the parties are unable to agree as to the amount of the adjustment, Owner may make a Claim therefor as provided in Paragraph 10.05. Such claims, costs, losses and damages will include but not be limited to all costs of repair, or replacement of work of others destroyed or damaged by correction, removal, or replacement of Contractor's defective Work.
- D. Contractor shall not be allowed an extension of the Contract Times because of any delay in the performance of the Work attributable to the exercise by Owner of Owner's rights and remedies under this Paragraph 13.09.

## **ARTICLE 14 – PAYMENTS TO CONTRACTOR AND COMPLETION**

### *14.01 Schedule of Values*

- A. The Schedule of Values established as provided in Paragraph 2.07.A will serve as the basis for progress payments and will be incorporated into a form of Application for Payment acceptable to Engineer. Progress payments on account of Unit Price Work will be based on the number of units completed.

### *14.02 Progress Payments*

#### *A. Applications for Payments:*

1. At least 20 days before the date established in the Agreement for each progress payment (but not more often than once a month), Contractor shall submit to Engineer for review an Application for Payment filled out and signed by Contractor covering the Work completed as of the date of the Application and accompanied by such supporting documentation as is required by the Contract Documents. If payment is requested on the basis of materials and equipment not incorporated in the Work but delivered and suitably stored at the Site or at another location agreed to in writing, the Application for Payment shall also be accompanied by a bill of sale, invoice, or other documentation warranting that Owner has received the materials and equipment free and clear of all Liens and evidence that the materials and equipment are covered by appropriate property insurance or other arrangements to protect Owner's interest therein, all of which must be satisfactory to Owner.
2. Beginning with the second Application for Payment, each Application shall include an affidavit of Contractor stating that all previous progress payments received on account of the



Work have been applied on account to discharge Contractor's legitimate obligations associated with prior Applications for Payment.

3. The amount of retainage with respect to progress payments will be as stipulated in the Agreement.

B. *Review of Applications:*

1. Engineer will, within 10 days after receipt of each Application for Payment, either indicate in writing a recommendation of payment and present the Application to Owner or return the Application to Contractor indicating in writing Engineer's reasons for refusing to recommend payment. In the latter case, Contractor may make the necessary corrections and resubmit the Application.
2. Engineer's recommendation of any payment requested in an Application for Payment will constitute a representation by Engineer to Owner, based on Engineer's observations of the executed Work as an experienced and qualified design professional, and on Engineer's review of the Application for Payment and the accompanying data and schedules, that to the best of Engineer's knowledge, information and belief:
  - a. the Work has progressed to the point indicated;
  - b. the quality of the Work is generally in accordance with the Contract Documents (subject to an evaluation of the Work as a functioning whole prior to or upon Substantial Completion, the results of any subsequent tests called for in the Contract Documents, a final determination of quantities and classifications for Unit Price Work under Paragraph 9.07, and any other qualifications stated in the recommendation); and
  - c. the conditions precedent to Contractor's being entitled to such payment appear to have been fulfilled in so far as it is Engineer's responsibility to observe the Work.
3. By recommending any such payment Engineer will not thereby be deemed to have represented that:
  - a. inspections made to check the quality or the quantity of the Work as it has been performed have been exhaustive, extended to every aspect of the Work in progress, or involved detailed inspections of the Work beyond the responsibilities specifically assigned to Engineer in the Contract Documents; or
  - b. there may not be other matters or issues between the parties that might entitle Contractor to be paid additionally by Owner or entitle Owner to withhold payment to Contractor.
4. Neither Engineer's review of Contractor's Work for the purposes of recommending payments nor Engineer's recommendation of any payment, including final payment, will impose responsibility on Engineer:
  - a. to supervise, direct, or control the Work, or

- b. for the means, methods, techniques, sequences, or procedures of construction, or the safety precautions and programs incident thereto, or
  - c. for Contractor's failure to comply with Laws and Regulations applicable to Contractor's performance of the Work, or
  - d. to make any examination to ascertain how or for what purposes Contractor has used the moneys paid on account of the Contract Price, or
  - e. to determine that title to any of the Work, materials, or equipment has passed to Owner free and clear of any Liens.
5. Engineer may refuse to recommend the whole or any part of any payment if, in Engineer's opinion, it would be incorrect to make the representations to Owner stated in Paragraph 14.02.B.2. Engineer may also refuse to recommend any such payment or, because of subsequently discovered evidence or the results of subsequent inspections or tests, revise or revoke any such payment recommendation previously made, to such extent as may be necessary in Engineer's opinion to protect Owner from loss because:
- a. the Work is defective, or completed Work has been damaged, requiring correction or replacement;
  - b. the Contract Price has been reduced by Change Orders;
  - c. Owner has been required to correct defective Work or complete Work in accordance with Paragraph 13.09; or
  - d. Engineer has actual knowledge of the occurrence of any of the events enumerated in Paragraph 15.02.A.

*C. Payment Becomes Due:*

- 1. Ten days after presentation of the Application for Payment to Owner with Engineer's recommendation, the amount recommended will (subject to the provisions of Paragraph 14.02.D) become due, and when due will be paid by Owner to Contractor.

*D. Reduction in Payment:*

- 1. Owner may refuse to make payment of the full amount recommended by Engineer because:
  - a. claims have been made against Owner on account of Contractor's performance or furnishing of the Work;
  - b. Liens have been filed in connection with the Work, except where Contractor has delivered a specific bond satisfactory to Owner to secure the satisfaction and discharge of such Liens;
  - c. there are other items entitling Owner to a set-off against the amount recommended; or

- d. Owner has actual knowledge of the occurrence of any of the events enumerated in Paragraphs 14.02.B.5.a through 14.02.B.5.c or Paragraph 15.02.A.
2. If Owner refuses to make payment of the full amount recommended by Engineer, Owner will give Contractor immediate written notice (with a copy to Engineer) stating the reasons for such action and promptly pay Contractor any amount remaining after deduction of the amount so withheld. Owner shall promptly pay Contractor the amount so withheld, or any adjustment thereto agreed to by Owner and Contractor, when Contractor remedies the reasons for such action.
3. Upon a subsequent determination that Owner's refusal of payment was not justified, the amount wrongfully withheld shall be treated as an amount due as determined by Paragraph 14.02.C.1 and subject to interest as provided in the Agreement.

#### 14.03 *Contractor's Warranty of Title*

- A. Contractor warrants and guarantees that title to all Work, materials, and equipment covered by any Application for Payment, whether incorporated in the Project or not, will pass to Owner no later than the time of payment free and clear of all Liens.

#### 14.04 *Substantial Completion*

- A. When Contractor considers the entire Work ready for its intended use Contractor shall notify Owner and Engineer in writing that the entire Work is substantially complete (except for items specifically listed by Contractor as incomplete) and request that Engineer issue a certificate of Substantial Completion.
- B. Promptly after Contractor's notification, Owner, Contractor, and Engineer shall make an inspection of the Work to determine the status of completion. If Engineer does not consider the Work substantially complete, Engineer will notify Contractor in writing giving the reasons therefor.
- C. If Engineer considers the Work substantially complete, Engineer will deliver to Owner a tentative certificate of Substantial Completion which shall fix the date of Substantial Completion. There shall be attached to the certificate a tentative list of items to be completed or corrected before final payment. Owner shall have seven days after receipt of the tentative certificate during which to make written objection to Engineer as to any provisions of the certificate or attached list. If, after considering such objections, Engineer concludes that the Work is not substantially complete, Engineer will, within 14 days after submission of the tentative certificate to Owner, notify Contractor in writing, stating the reasons therefor. If, after consideration of Owner's objections, Engineer considers the Work substantially complete, Engineer will, within said 14 days, execute and deliver to Owner and Contractor a definitive certificate of Substantial Completion (with a revised tentative list of items to be completed or corrected) reflecting such changes from the tentative certificate as Engineer believes justified after consideration of any objections from Owner.
- D. At the time of delivery of the tentative certificate of Substantial Completion, Engineer will deliver to Owner and Contractor a written recommendation as to division of responsibilities

pending final payment between Owner and Contractor with respect to security, operation, safety, and protection of the Work, maintenance, heat, utilities, insurance, and warranties and guarantees. Unless Owner and Contractor agree otherwise in writing and so inform Engineer in writing prior to Engineer's issuing the definitive certificate of Substantial Completion, Engineer's aforesaid recommendation will be binding on Owner and Contractor until final payment.

- E. Owner shall have the right to exclude Contractor from the Site after the date of Substantial Completion subject to allowing Contractor reasonable access to remove its property and complete or correct items on the tentative list.

#### 14.05 *Partial Utilization*

- A. Prior to Substantial Completion of all the Work, Owner may use or occupy any substantially completed part of the Work which has specifically been identified in the Contract Documents, or which Owner, Engineer, and Contractor agree constitutes a separately functioning and usable part of the Work that can be used by Owner for its intended purpose without significant interference with Contractor's performance of the remainder of the Work, subject to the following conditions:

1. Owner at any time may request Contractor in writing to permit Owner to use or occupy any such part of the Work which Owner believes to be ready for its intended use and substantially complete. If and when Contractor agrees that such part of the Work is substantially complete, Contractor, Owner, and Engineer will follow the procedures of Paragraph 14.04.A through D for that part of the Work.
2. Contractor at any time may notify Owner and Engineer in writing that Contractor considers any such part of the Work ready for its intended use and substantially complete and request Engineer to issue a certificate of Substantial Completion for that part of the Work.
3. Within a reasonable time after either such request, Owner, Contractor, and Engineer shall make an inspection of that part of the Work to determine its status of completion. If Engineer does not consider that part of the Work to be substantially complete, Engineer will notify Owner and Contractor in writing giving the reasons therefor. If Engineer considers that part of the Work to be substantially complete, the provisions of Paragraph 14.04 will apply with respect to certification of Substantial Completion of that part of the Work and the division of responsibility in respect thereof and access thereto.
4. No use or occupancy or separate operation of part of the Work may occur prior to compliance with the requirements of Paragraph 5.10 regarding property insurance.

#### 14.06 *Final Inspection*

- A. Upon written notice from Contractor that the entire Work or an agreed portion thereof is complete, Engineer will promptly make a final inspection with Owner and Contractor and will notify Contractor in writing of all particulars in which this inspection reveals that the Work is incomplete or defective. Contractor shall immediately take such measures as are necessary to complete such Work or remedy such deficiencies.

## 14.07 *Final Payment*

### A. *Application for Payment:*

1. After Contractor has, in the opinion of Engineer, satisfactorily completed all corrections identified during the final inspection and has delivered, in accordance with the Contract Documents, all maintenance and operating instructions, schedules, guarantees, bonds, certificates or other evidence of insurance, certificates of inspection, marked-up record documents (as provided in Paragraph 6.12), and other documents, Contractor may make application for final payment following the procedure for progress payments.
2. The final Application for Payment shall be accompanied (except as previously delivered) by:
  - a. all documentation called for in the Contract Documents, including but not limited to the evidence of insurance required by Paragraph 5.04.B.6;
  - b. consent of the surety, if any, to final payment;
  - c. a list of all Claims against Owner that Contractor believes are unsettled; and
  - d. complete and legally effective releases or waivers (satisfactory to Owner) of all Lien rights arising out of or Liens filed in connection with the Work.
3. In lieu of the releases or waivers of Liens specified in Paragraph 14.07.A.2 and as approved by Owner, Contractor may furnish receipts or releases in full and an affidavit of Contractor that: (i) the releases and receipts include all labor, services, material, and equipment for which a Lien could be filed; and (ii) all payrolls, material and equipment bills, and other indebtedness connected with the Work for which Owner might in any way be responsible, or which might in any way result in liens or other burdens on Owner's property, have been paid or otherwise satisfied. If any Subcontractor or Supplier fails to furnish such a release or receipt in full, Contractor may furnish a bond or other collateral satisfactory to Owner to indemnify Owner against any Lien.

### B. *Engineer's Review of Application and Acceptance:*

1. If, on the basis of Engineer's observation of the Work during construction and final inspection, and Engineer's review of the final Application for Payment and accompanying documentation as required by the Contract Documents, Engineer is satisfied that the Work has been completed and Contractor's other obligations under the Contract Documents have been fulfilled, Engineer will, within ten days after receipt of the final Application for Payment, indicate in writing Engineer's recommendation of payment and present the Application for Payment to Owner for payment. At the same time Engineer will also give written notice to Owner and Contractor that the Work is acceptable subject to the provisions of Paragraph 14.09. Otherwise, Engineer will return the Application for Payment to Contractor, indicating in writing the reasons for refusing to recommend final payment, in which case Contractor shall make the necessary corrections and resubmit the Application for Payment.

### C. *Payment Becomes Due:*

1. Thirty days after the presentation to Owner of the Application for Payment and accompanying documentation, the amount recommended by Engineer, less any sum Owner is entitled to set off against Engineer's recommendation, including but not limited to liquidated damages, will become due and will be paid by Owner to Contractor.

#### 14.08 *Final Completion Delayed*

- A. If, through no fault of Contractor, final completion of the Work is significantly delayed, and if Engineer so confirms, Owner shall, upon receipt of Contractor's final Application for Payment (for Work fully completed and accepted) and recommendation of Engineer, and without terminating the Contract, make payment of the balance due for that portion of the Work fully completed and accepted. If the remaining balance to be held by Owner for Work not fully completed or corrected is less than the retainage stipulated in the Agreement, and if bonds have been furnished as required in Paragraph 5.01, the written consent of the surety to the payment of the balance due for that portion of the Work fully completed and accepted shall be submitted by Contractor to Engineer with the Application for such payment. Such payment shall be made under the terms and conditions governing final payment, except that it shall not constitute a waiver of Claims.

#### 14.09 *Waiver of Claims*

- A. The making and acceptance of final payment will constitute:
  1. a waiver of all Claims by Owner against Contractor, except Claims arising from unsettled Liens, from defective Work appearing after final inspection pursuant to Paragraph 14.06, from failure to comply with the Contract Documents or the terms of any special guarantees specified therein, or from Contractor's continuing obligations under the Contract Documents; and
  2. a waiver of all Claims by Contractor against Owner other than those previously made in accordance with the requirements herein and expressly acknowledged by Owner in writing as still unsettled.

### **ARTICLE 15 – SUSPENSION OF WORK AND TERMINATION**

#### 15.01 *Owner May Suspend Work*

- A. At any time and without cause, Owner may suspend the Work or any portion thereof for a period of not more than 90 consecutive days by notice in writing to Contractor and Engineer which will fix the date on which Work will be resumed. Contractor shall resume the Work on the date so fixed. Contractor shall be granted an adjustment in the Contract Price or an extension of the Contract Times, or both, directly attributable to any such suspension if Contractor makes a Claim therefor as provided in Paragraph 10.05.

#### 15.02 *Owner May Terminate for Cause*

- A. The occurrence of any one or more of the following events will justify termination for cause:

1. Contractor's persistent failure to perform the Work in accordance with the Contract Documents (including, but not limited to, failure to supply sufficient skilled workers or suitable materials or equipment or failure to adhere to the Progress Schedule established under Paragraph 2.07 as adjusted from time to time pursuant to Paragraph 6.04);
  2. Contractor's disregard of Laws or Regulations of any public body having jurisdiction;
  3. Contractor's repeated disregard of the authority of Engineer; or
  4. Contractor's violation in any substantial way of any provisions of the Contract Documents.
- B. If one or more of the events identified in Paragraph 15.02.A occur, Owner may, after giving Contractor (and surety) seven days written notice of its intent to terminate the services of Contractor:
1. exclude Contractor from the Site, and take possession of the Work and of all Contractor's tools, appliances, construction equipment, and machinery at the Site, and use the same to the full extent they could be used by Contractor (without liability to Contractor for trespass or conversion);
  2. incorporate in the Work all materials and equipment stored at the Site or for which Owner has paid Contractor but which are stored elsewhere; and
  3. complete the Work as Owner may deem expedient.
- C. If Owner proceeds as provided in Paragraph 15.02.B, Contractor shall not be entitled to receive any further payment until the Work is completed. If the unpaid balance of the Contract Price exceeds all claims, costs, losses, and damages (including but not limited to all fees and charges of engineers, architects, attorneys, and other professionals and all court or arbitration or other dispute resolution costs) sustained by Owner arising out of or relating to completing the Work, such excess will be paid to Contractor. If such claims, costs, losses, and damages exceed such unpaid balance, Contractor shall pay the difference to Owner. Such claims, costs, losses, and damages incurred by Owner will be reviewed by Engineer as to their reasonableness and, when so approved by Engineer, incorporated in a Change Order. When exercising any rights or remedies under this Paragraph, Owner shall not be required to obtain the lowest price for the Work performed.
- D. Notwithstanding Paragraphs 15.02.B and 15.02.C, Contractor's services will not be terminated if Contractor begins within seven days of receipt of notice of intent to terminate to correct its failure to perform and proceeds diligently to cure such failure within no more than 30 days of receipt of said notice.
- E. Where Contractor's services have been so terminated by Owner, the termination will not affect any rights or remedies of Owner against Contractor then existing or which may thereafter accrue. Any retention or payment of moneys due Contractor by Owner will not release Contractor from liability.

- F. If and to the extent that Contractor has provided a performance bond under the provisions of Paragraph 5.01.A, the termination procedures of that bond shall supersede the provisions of Paragraphs 15.02.B and 15.02.C.

#### 15.03 *Owner May Terminate For Convenience*

- A. Upon seven days written notice to Contractor and Engineer, Owner may, without cause and without prejudice to any other right or remedy of Owner, terminate the Contract. In such case, Contractor shall be paid for (without duplication of any items):
  - 1. completed and acceptable Work executed in accordance with the Contract Documents prior to the effective date of termination, including fair and reasonable sums for overhead and profit on such Work;
  - 2. expenses sustained prior to the effective date of termination in performing services and furnishing labor, materials, or equipment as required by the Contract Documents in connection with uncompleted Work, plus fair and reasonable sums for overhead and profit on such expenses;
  - 3. all claims, costs, losses, and damages (including but not limited to all fees and charges of engineers, architects, attorneys, and other professionals and all court or arbitration or other dispute resolution costs) incurred in settlement of terminated contracts with Subcontractors, Suppliers, and others; and
  - 4. reasonable expenses directly attributable to termination.
- B. Contractor shall not be paid on account of loss of anticipated profits or revenue or other economic loss arising out of or resulting from such termination.

#### 15.04 *Contractor May Stop Work or Terminate*

- A. If, through no act or fault of Contractor, (i) the Work is suspended for more than 90 consecutive days by Owner or under an order of court or other public authority, or (ii) Engineer fails to act on any Application for Payment within 30 days after it is submitted, or (iii) Owner fails for 30 days to pay Contractor any sum finally determined to be due, then Contractor may, upon seven days written notice to Owner and Engineer, and provided Owner or Engineer do not remedy such suspension or failure within that time, terminate the Contract and recover from Owner payment on the same terms as provided in Paragraph 15.03.
- B. In lieu of terminating the Contract and without prejudice to any other right or remedy, if Engineer has failed to act on an Application for Payment within 30 days after it is submitted, or Owner has failed for 30 days to pay Contractor any sum finally determined to be due, Contractor may, seven days after written notice to Owner and Engineer, stop the Work until payment is made of all such amounts due Contractor, including interest thereon. The provisions of this Paragraph 15.04 are not intended to preclude Contractor from making a Claim under Paragraph 10.05 for an adjustment in Contract Price or Contract Times or otherwise for expenses or damage directly attributable to Contractor's stopping the Work as permitted by this Paragraph.



## ARTICLE 16 – DISPUTE RESOLUTION

### 16.01 *Methods and Procedures*

- A. Either Owner or Contractor may request mediation of any Claim submitted to Engineer for a decision under Paragraph 10.05 before such decision becomes final and binding. The mediation will be governed by the Construction Industry Mediation Rules of the American Arbitration Association in effect as of the Effective Date of the Agreement. The request for mediation shall be submitted in writing to the American Arbitration Association and the other party to the Contract. Timely submission of the request shall stay the effect of Paragraph 10.05.E.
- B. Owner and Contractor shall participate in the mediation process in good faith. The process shall be concluded within 60 days of filing of the request. The date of termination of the mediation shall be determined by application of the mediation rules referenced above.
- C. If the Claim is not resolved by mediation, Engineer’s action under Paragraph 10.05.C or a denial pursuant to Paragraphs 10.05.C.3 or 10.05.D shall become final and binding 30 days after termination of the mediation unless, within that time period, Owner or Contractor:
  - 1. elects in writing to invoke any dispute resolution process provided for in the Supplementary Conditions; or
  - 2. agrees with the other party to submit the Claim to another dispute resolution process; or
  - 3. gives written notice to the other party of the intent to submit the Claim to a court of competent jurisdiction.

## ARTICLE 17 – MISCELLANEOUS

### 17.01 *Giving Notice*

- A. Whenever any provision of the Contract Documents requires the giving of written notice, it will be deemed to have been validly given if:
  - 1. delivered in person to the individual or to a member of the firm or to an officer of the corporation for whom it is intended; or
  - 2. delivered at or sent by registered or certified mail, postage prepaid, to the last business address known to the giver of the notice.

### 17.02 *Computation of Times*

- A. When any period of time is referred to in the Contract Documents by days, it will be computed to exclude the first and include the last day of such period. If the last day of any such period falls on a Saturday or Sunday or on a day made a legal holiday by the law of the applicable jurisdiction, such day will be omitted from the computation.

### 17.03 *Cumulative Remedies*

- A. The duties and obligations imposed by these General Conditions and the rights and remedies available hereunder to the parties hereto are in addition to, and are not to be construed in any way as a limitation of, any rights and remedies available to any or all of them which are otherwise imposed or available by Laws or Regulations, by special warranty or guarantee, or by other provisions of the Contract Documents. The provisions of this Paragraph will be as effective as if repeated specifically in the Contract Documents in connection with each particular duty, obligation, right, and remedy to which they apply.

### 17.04 *Survival of Obligations*

- A. All representations, indemnifications, warranties, and guarantees made in, required by, or given in accordance with the Contract Documents, as well as all continuing obligations indicated in the Contract Documents, will survive final payment, completion, and acceptance of the Work or termination or completion of the Contract or termination of the services of Contractor.

### 17.05 *Controlling Law*

- A. This Contract is to be governed by the law of the state in which the Project is located.

### 17.06 *Headings*

- A. Article and paragraph headings are inserted for convenience only and do not constitute parts of these General Conditions.

H:\PRIVATE\SPEC\Ctsparts\GeneralConditions2007.doc

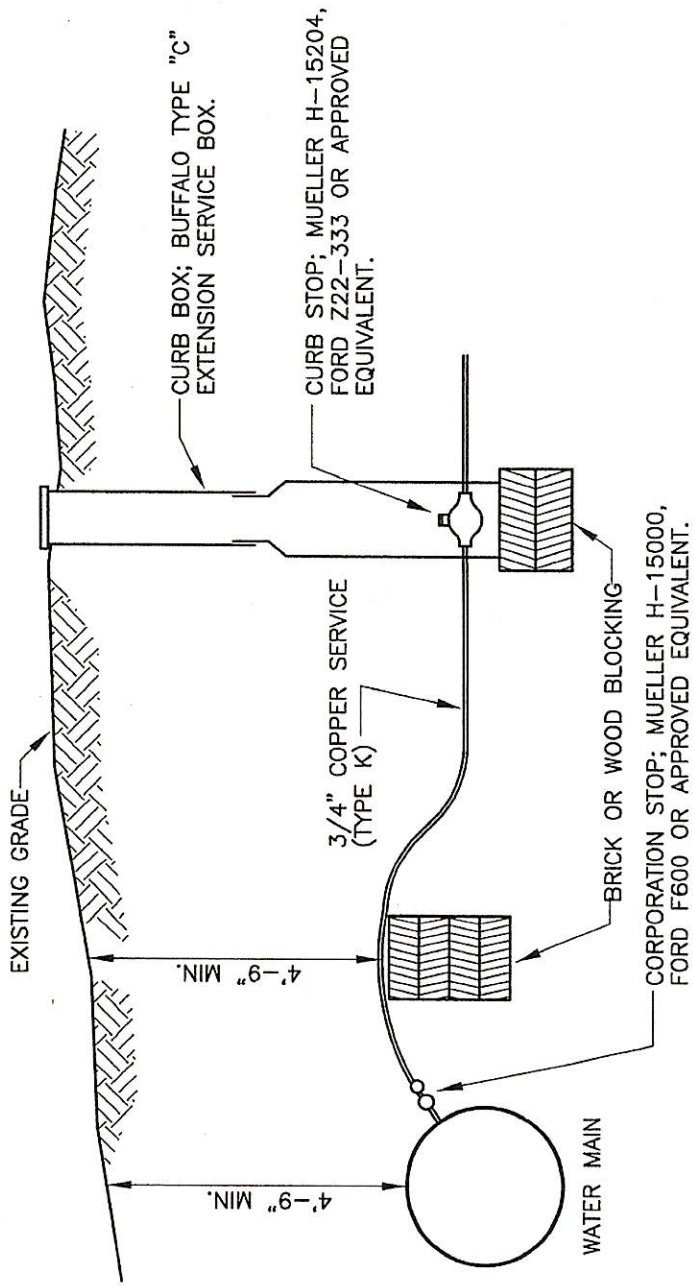

# SERVICE TIE-IN FOR INSIDE METER

9/93

SD-4-8

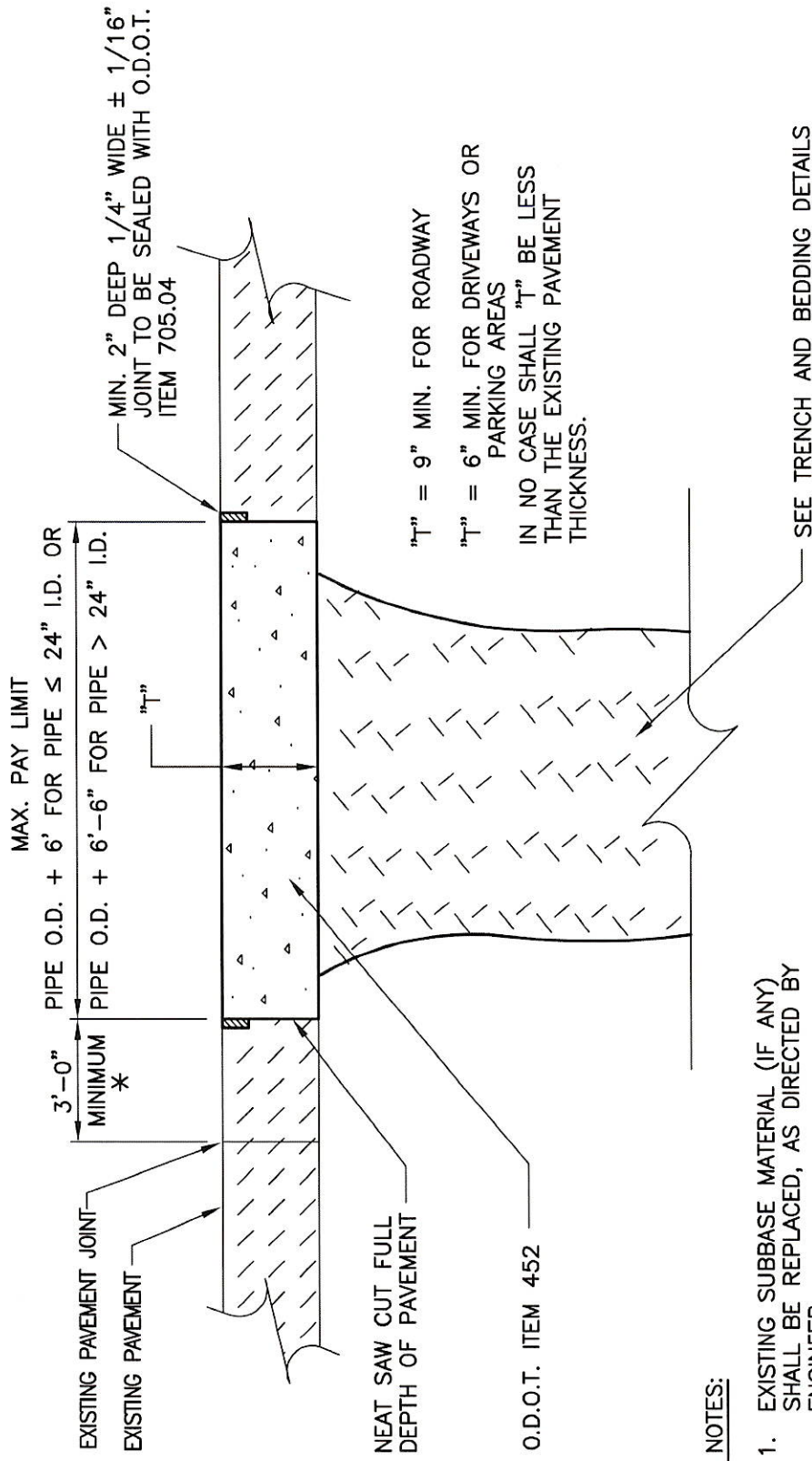

**NOTES:**

1. EXISTING SUBBASE MATERIAL (IF ANY) SHALL BE REPLACED, AS DIRECTED BY ENGINEER.
  2. REPLACEMENT SHALL BE REINFORCED AS PER O.D.O.T. ITEM 709.10 OR 709.12 IF EXISTING PAVEMENT IS REINFORCED.
  3. 5/8"  $\phi$  HOOKBOLT @ 30" O.C. MAY BE REQUIRED AS DIRECTED BY THE ENGINEER.
- \* WHERE WIDTH IS LESS THAN 3'-0" OR EXISTING PAVEMENT IS DETERIORATED, THE CONTRACTOR SHALL REPLACE ADDITIONAL PAVEMENT AS DIRECTED BY THE ENGINEER. PAYMENT FOR ADDITIONAL PAVEMENT REPLACEMENT AS DIRECTED BY THE ENGINEER SHALL BE AT THE SAME UNIT PRICE BID.

**TYPE A PAVEMENT REPLACEMENT**

(CONCRETE)

10/10

SD-5-1

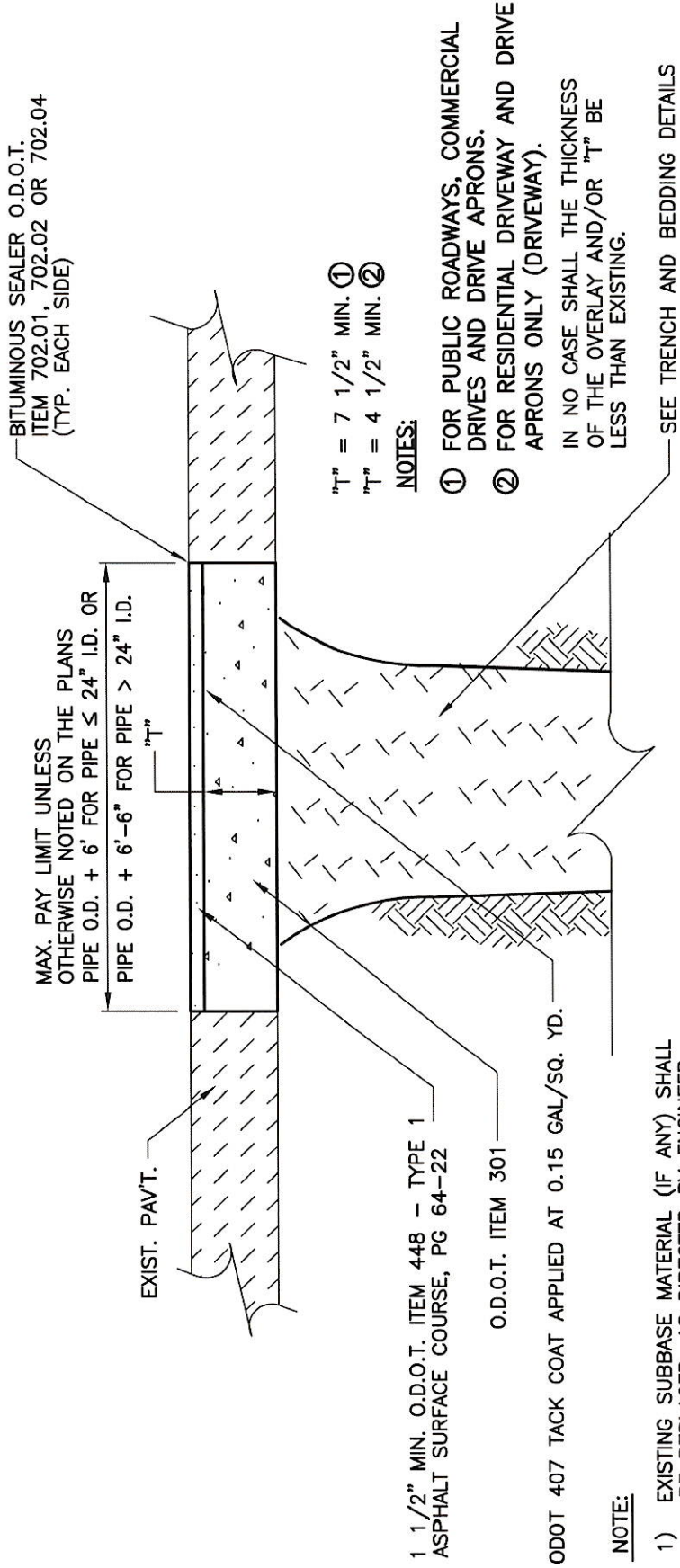

BITUMINOUS SEALER O.D.O.T. ITEM 702.01, 702.02 OR 702.04 (TYP. EACH SIDE)

MAX. PAY LIMIT UNLESS OTHERWISE NOTED ON THE PLANS PIPE O.D. + 6" FOR PIPE ≤ 24" I.D. OR PIPE O.D. + 6'-6" FOR PIPE > 24" I.D.

EXIST. PAVT.

"T" = 7 1/2" MIN. ①  
 "T" = 4 1/2" MIN. ②

NOTES:

- ① FOR PUBLIC ROADWAYS, COMMERCIAL DRIVES AND DRIVE APRONS.
  - ② FOR RESIDENTIAL DRIVEWAY AND DRIVE APRONS ONLY (DRIVEWAY).
- IN NO CASE SHALL THE THICKNESS OF THE OVERLAY AND/OR "T" BE LESS THAN EXISTING.

1 1/2" MIN. O.D.O.T. ITEM 448 - TYPE 1 ASPHALT SURFACE COURSE, PG 64-22

O.D.O.T. ITEM 301

ODOT 407 TACK COAT APPLIED AT 0.15 GAL/SQ. YD.

NOTE:

- 1) EXISTING SUBBASE MATERIAL (IF ANY) SHALL BE REPLACED, AS DIRECTED BY ENGINEER.

TYPE C PAVEMENT REPLACEMENT

(ASPHALT)

10/10

SD-5-3



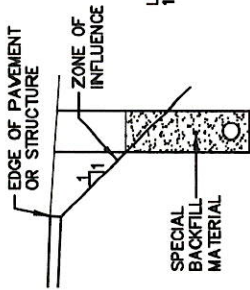

PARALLEL  
ZONE OF INFLUENCE

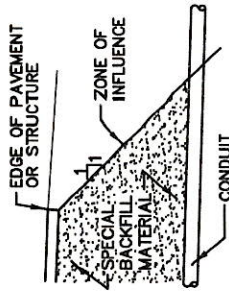

TRANSVERSE  
ZONE OF INFLUENCE

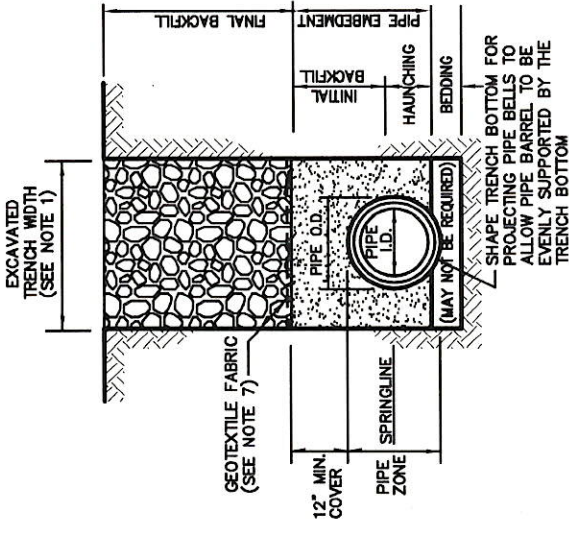

CLASS 'C' PIPE EMBEDMENT

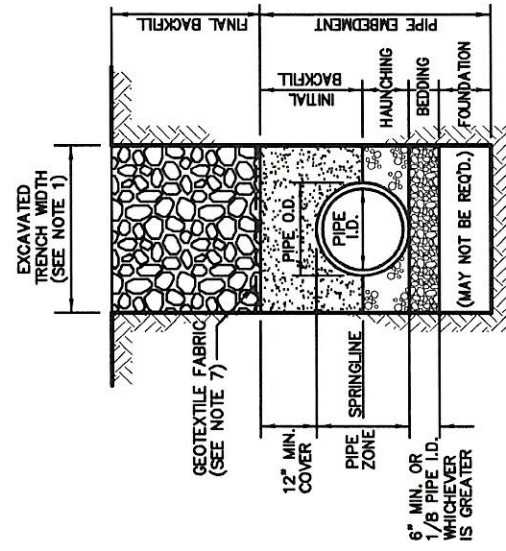

CLASS 'B' PIPE EMBEDMENT

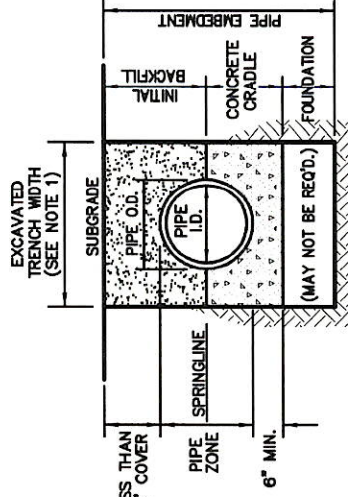

CLASS 'A' PIPE EMBEDMENT

NOTES:

1. MAXIMUM EXCAVATED TRENCH WIDTH: THE MAXIMUM EXCAVATED TRENCH WIDTH FROM THE BOTTOM OF THE TRENCH TO 12" OVER THE TOP OF THE PIPE (WITHIN PIPE EMBEDMENT) SHALL BE O.D. + 24" FOR ALL PIPES UP TO AND INCLUDING 24" I.D. + 30" FOR PIPE FROM 24" I.D. TO 54" I.D. AND O.D. + 48" FOR PIPES SIZES 60" I.D. AND OVER.
2. FOUNDATION: WHERE AN UNSTABLE TRENCH BOTTOM CONDITION IS ENCOUNTERED, THE CONTRACTOR SHALL EXCAVATE TO A DEPTH REQUIRED BY THE ENGINEER AND REPLACE WITH MATERIAL AS DIRECTED BY THE ENGINEER.
3. PIPE EMBEDMENT:

CLASS A: CLASS A PIPE EMBEDMENT SHALL BE USED FOR ALL PIPING UNDER PAVEMENT OR STRUCTURES WITH LESS THAN 12 INCHES OF PIPE COVER TO THE SUBGRADE. THE CONCRETE CRADLE SHALL BE IN ACCORDANCE WITH ODOT ITEM 489, CLASS "C". THE INITIAL BACKFILL SHALL BE AASHTO NO. 57 OR NO. 67 GRANULAR PIPE EMBEDMENT.

CLASS B: CLASS B PIPE EMBEDMENT SHALL BE USED FOR ALL PIPING UNLESS OTHERWISE NOTED ON THE PLANS OR AUTHORIZED BY THE ENGINEER. THE BEDDING AND HAUNCHING SHALL BE AASHTO NO. 57 OR NO. 67 GRANULAR PIPE EMBEDMENT. IN ALL AREAS UNDER PAVEMENT, STRUCTURES OR WITHIN THE ZONE OF INFLUENCE, THE INITIAL BACKFILL SHALL BE AASHTO NO. 57 OR NO. 67 STONE GRANULAR PIPE EMBEDMENT. IN ALL AREAS OUTSIDE OF PAVEMENT, STRUCTURES OR THE ZONE OF INFLUENCE, THE INITIAL BACKFILL SHALL BE SUITABLE ON-SITE MATERIAL APPROVED BY THE ENGINEER FOR ONLY REINFORCED CONCRETE PIPE AND DUCTILE IRON PIPE. THE INITIAL BACKFILL FOR ALL OTHER PIPES SHALL BE AASHTO NO. 57 OR NO. 67 GRANULAR PIPE EMBEDMENT.

CLASS C: CLASS C PIPE EMBEDMENT SHALL ONLY BE USED FOR DUCTILE IRON WATER MAIN, DUCTILE IRON FORCE MAINS OR AS AUTHORIZED BY THE ENGINEER. THE PIPE EMBEDMENT SHALL BE AASHTO NO. 57 OR NO. 67 GRANULAR PIPE EMBEDMENT IN ALL AREAS UNDER PAVEMENT, STRUCTURES OR WITHIN THE ZONE OF INFLUENCE. THE PIPE EMBEDMENT SHALL BE SUITABLE ON-SITE MATERIAL APPROVED BY THE ENGINEER IN ALL AREAS OUTSIDE OF PAVEMENT, STRUCTURES OR THE ZONE OF INFLUENCE. WHERE ROCK OR SHALE IS ENCOUNTERED, A MINIMUM 6-INCHES OF AASHTO NO. 57 OR NO. 67 GRANULAR PIPE BEDDING OR SAND BEDDING SHALL BE PLACED AS DIRECTED BY THE ENGINEER.

4. FINAL BACKFILL: IN ALL AREAS UNDER PAVEMENT, STRUCTURES OR WITHIN THE ZONE OF INFLUENCE THE FINAL BACKFILL SHALL BE SPECIAL BACKFILL MATERIAL IN ALL AREAS OUTSIDE OF PAVEMENT, STRUCTURES OR THE ZONE OF INFLUENCE, THE FINAL BACKFILL SHALL BE SUITABLE ON-SITE MATERIAL APPROVED BY THE ENGINEER.
5. SPECIFICATIONS: ALL TRENCHING, PIPE EMBEDMENT AND BACKFILL MATERIALS SHALL BE IN ACCORDANCE WITH SPECIFICATION 02300CT - EARTHWORK.
6. CLAY TRENCH DAMS: CLAY TRENCH DAMS SHALL BE REQUIRED AS SHOWN ON PLANS OR WHEN AND WHERE NECESSARY AS DIRECTED BY THE ENGINEER.
7. GEOTEXTILE FABRIC: INSTALL A GEOTEXTILE FABRIC IN ACCORDANCE WITH ODOT 712.09, TYPE A, AFTER ALL INITIAL BACKFILL CONSISTING OF AASHTO NO. 57 OR NO. 67 GRANULAR PIPE EMBEDMENT.
8. DETECTOR TAPE: IF REQUIRED IN THE SPECIFICATIONS, INSTALL DETECTABLE WARNING TAPE ABOVE UTILITIES, 12" BELOW FINISHED GRADE, EXCEPT 6 INCHES BELOW SUBGRADE UNDER PAVEMENT AND SLABS.

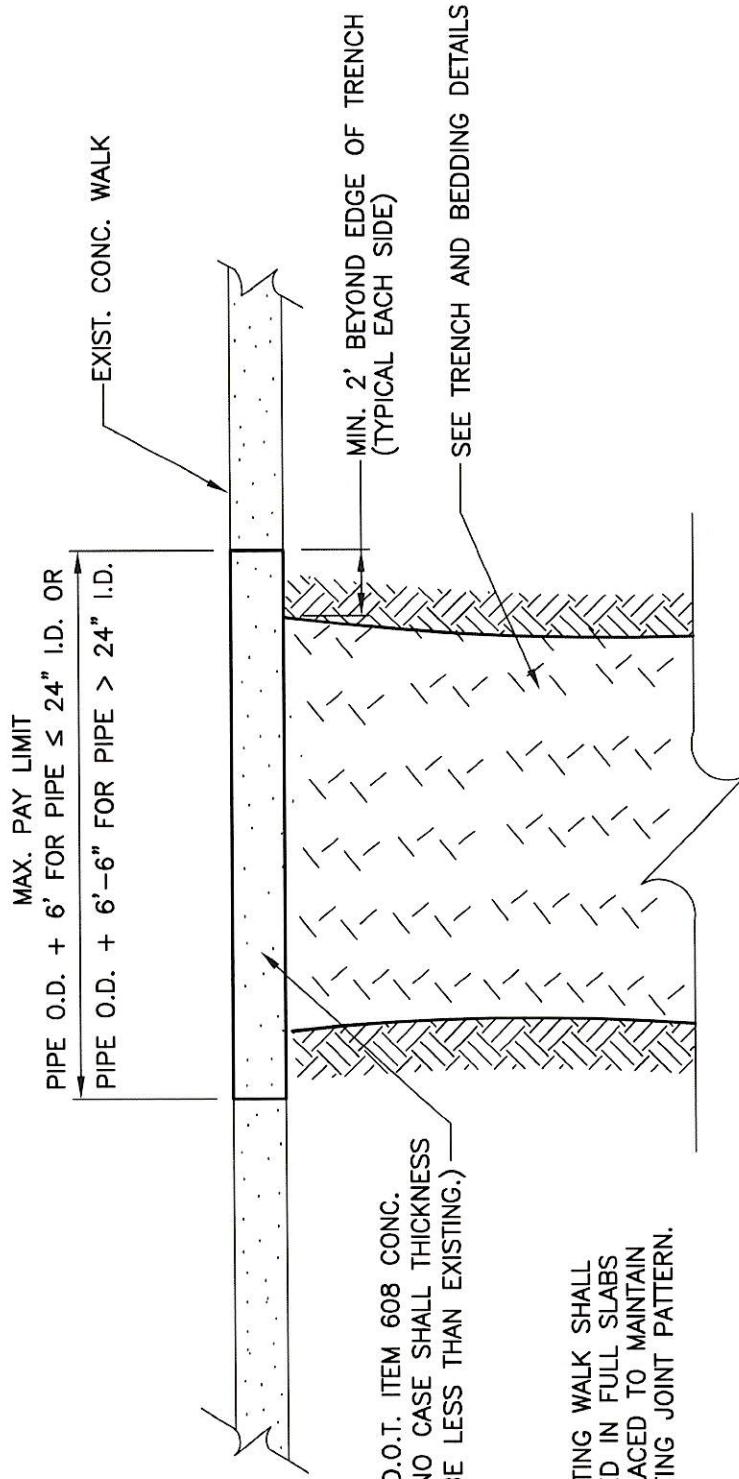

# TYPE A WALK REPLACEMENT

SD-5-7

12/88

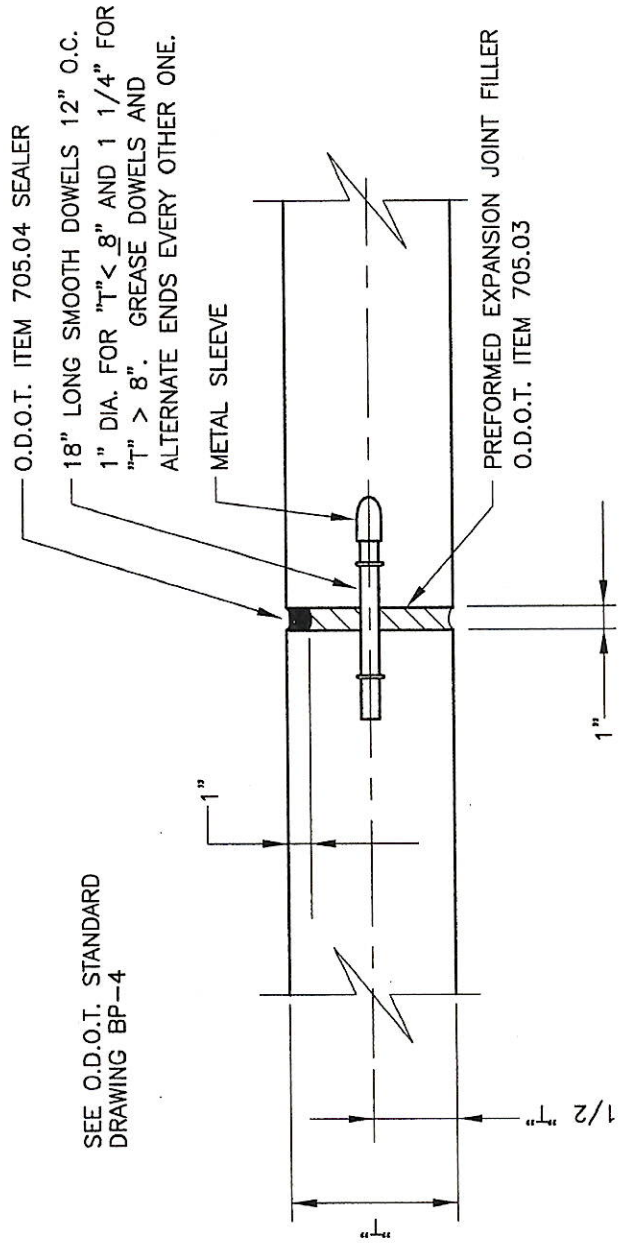

NOTE: EXPANSION JOINTS SHALL BE USED AT ALL INTERSECTIONS AND WHERE DESIGNATED ON THE PLANS OR BY THE ENGINEER.

## EXPANSION JOINT

11/88 SD-5-9



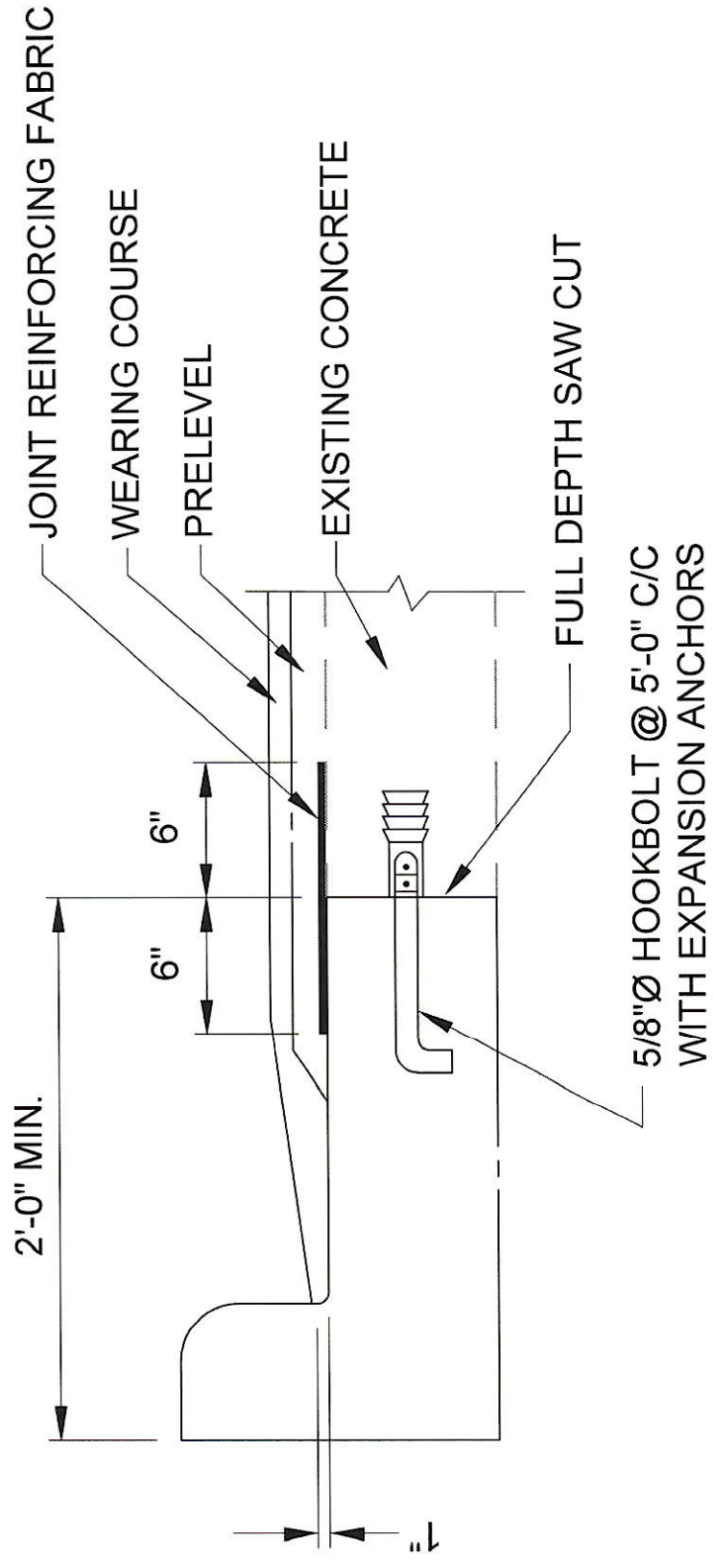

# CURB REPLACEMENT DETAIL

(WITH ASPHALT OVERLAY)

SD-5-16

